



TYGER[®]

TYGER ARMOR[™]

BEFORE INSTALLATION

READ INSTRUCTIONS CAREFULLY BEFORE STARTING INSTALLATION. REMOVE CONTENTS FROM BOX AND VERIFY ALL PARTS ARE PRESENT. ASSISTANCE IS RECOMMENDED. FAILURE TO IDENTIFY DAMAGE BEFORE INSTALLATION COULD LEAD TO A REJECTION OF ANY CLAIM.

WARNING

TO PROTECT YOUR INVESTMENT, WAX THIS PRODUCT AFTER INSTALLING. REGULAR WAXING IS RECOMMENDED TO ADD A PROTECTIVE LAYER OVER THE FINISH. DO NOT USE ANY TYPE OF POLISH OR WAX THAT MAY CONTAIN ABRA-SIVES THAT COULD DAMAGE THE FINISH. USE ONLY MILD SOAP TO CLEAN THE SIDE ARMOR.

TG-AM2F20298

Parts List

- x1** Driver/Left Side Armor Assembly
- x1** Passenger/Right Side Armor Assembly
- x12** 10mm Clip Nuts
- x24** 10-1.5mm x 30mm Hex Bolts
- x36** 10mm x 27mm OD x 3mm Flat Washers
- x12** 10mm Lock Washers
- x12** 10mm Nylon Lock Nuts

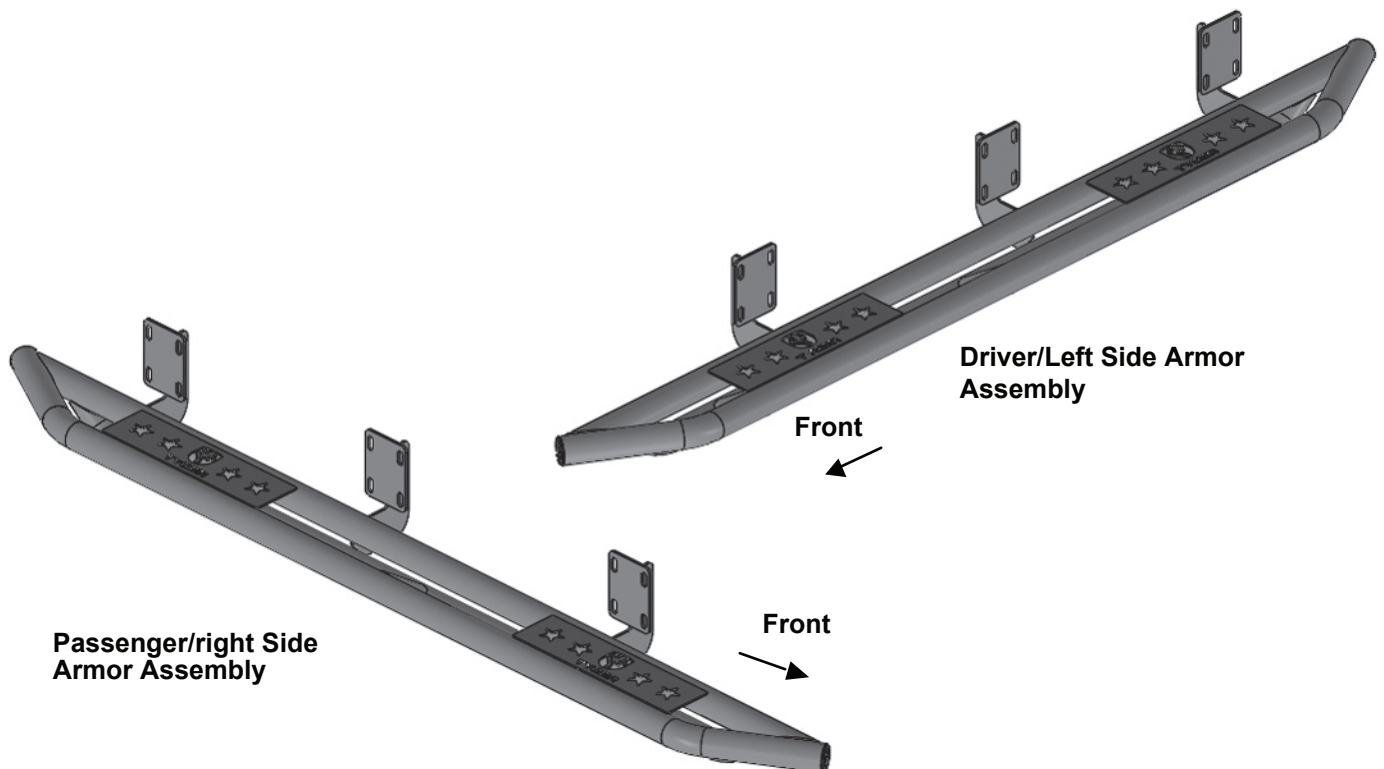



STEP 1

Starting on the driver side of the vehicle, locate the (4) pairs of factory holes along the bottom of the body, (pinch weld).

NOTE: Side Armor will attach to the 2nd, 3rd and 4th mounting locations, (Fig 1). Hold up the Driver / Left Side Armor to help determine the correct mounting locations.

NOTE: The inner holes may be covered with sealing tape or insulation.

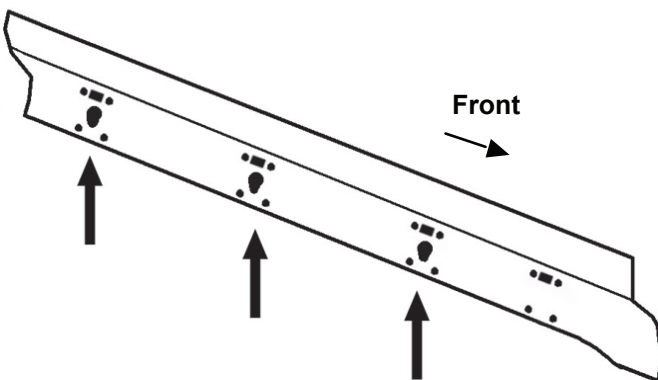

(Fig 1) Driver/Left inner body panel illustrated

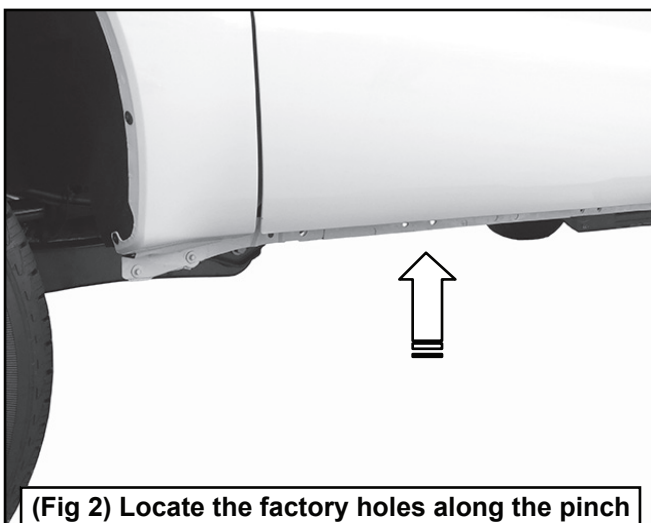

(Fig 2) Locate the factory holes along the pinch weld. Start at the 2nd pair of factory holes

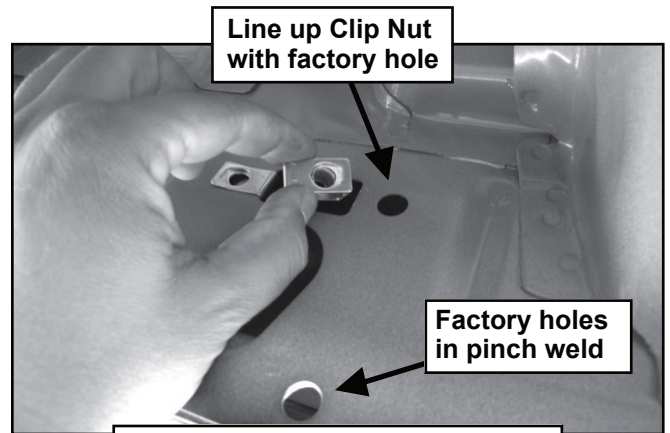

(Fig 3) Typical Mounting Location

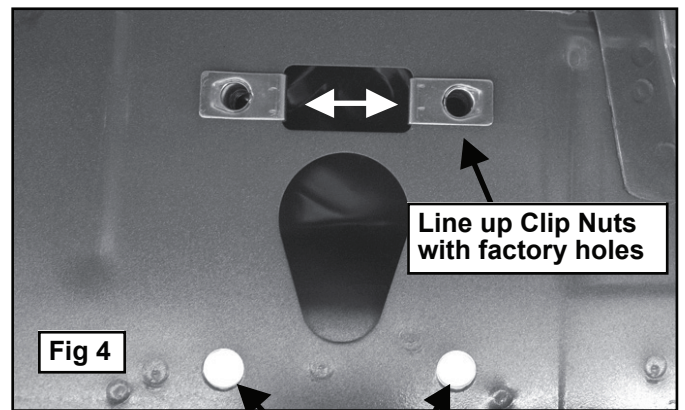

Fig 4

Factory holes in pinch weld pictured from behind body panel

STEP 2

Move to the 2nd pair of holes along the pinch weld, (Fig 1 & 2). Select (2) 10mm Clip Nuts. Slide the 10mm Clip Nuts into the rectangular opening with the nut towards the inside. Line up the threaded nut on the clip with the round holes on each side of the rectangular opening, (Fig 3 & 4).

STEP 3

Repeat Step 2 to install (2) 10mm Clip Nuts on the center and rear mounting locations.



TYGER®

STEP 4

Select the Driver / Left Side Armor. With assistance, carefully position the Side Armor up to and against the (3) mounting locations. Attach the Side Armor to the (6) 10mm Clip Nuts with (6) 10mm Hex Bolts, (6) 10mm Lock Washers and (6) 10mm Flat Washers, (Fig 5-7). Do not tighten at this time.

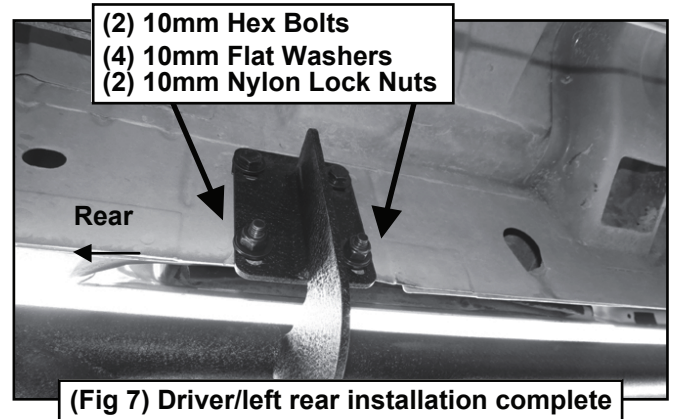
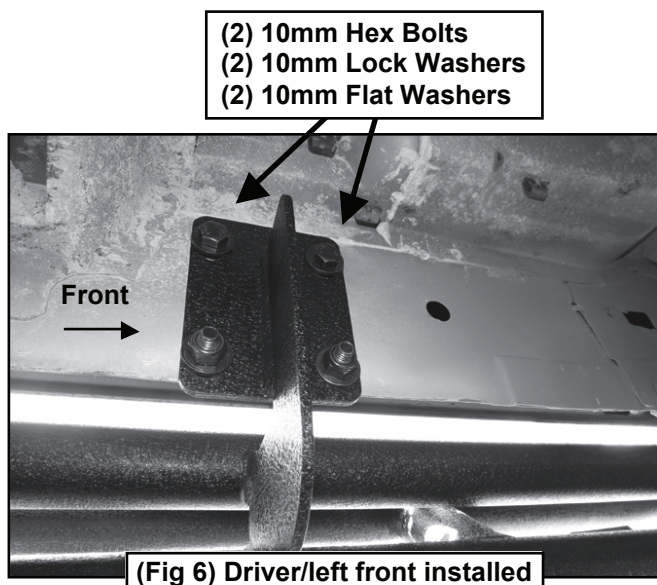
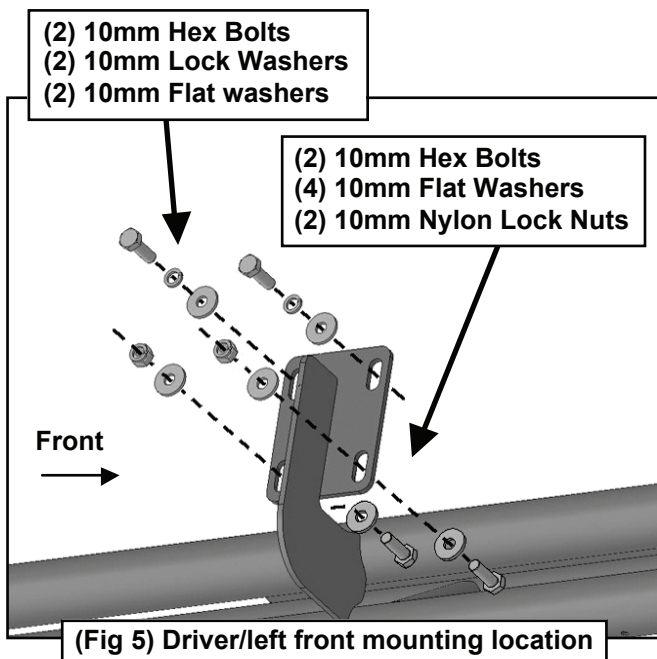

STEP 5

Line up the holes in the bottom of the mounting brackets on the Side Armor with the (6) mounting holes in the pinch weld. Attach the Side Armor to the pinch weld with (6) 10mm Hex Bolts, (12) 10mm Flat Washers, (6) 10mm Nylon Lock Nuts, (Fig 5-7).

NOTE: Insert Hex Bolt with Flat Washer through pinch weld first, then through bracket. Do not fully tighten.

STEP 6

Level and adjust the Side Armor properly and tighten all hardware. Repeat Steps 1-6 for Passenger / Right Side Armor assembly installation, do periodic inspections to the installation to make sure that all hardware is secure and tight.

