



TYGER[®]

TYGER ARMOR[™]

TG-AM2F20138

Parts List

- x1** Driver Side Armor
- x1** Passenger Side Armor
- x12** 8mm Plastic Washers
- x12** 8mm x 24mm OD x 2mm Flat Washers
- x12** 8mm Nylon Lock Nuts

Before Installation

READ INSTRUCTIONS CAREFULLY BEFORE STARTING INSTALLATION. REMOVE CONTENTS FROM BOX AND VERIFY ALL PARTS ARE PRESENT. ASSISTANCE IS RECOMMENDED.

Warning

To protect your investment, wax this product after installing. Regular waxing is recommended to add a protective layer over the finish. Do not use any type of polish or wax that may contain abrasives that could damage the finish. Use only mild soap to clean the Side Armor.

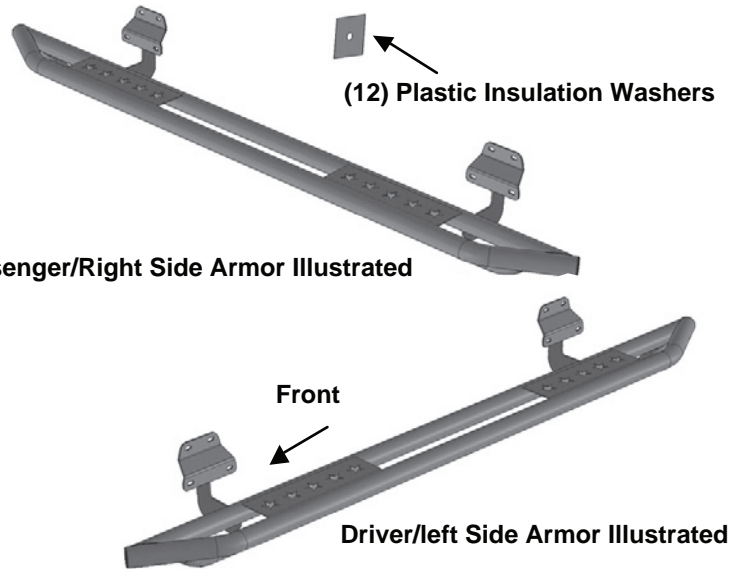

STEP 1

Start the installation under the passenger side of the vehicle. Locate the front factory running board mounting location along the inner side of the body, (Figure 1).

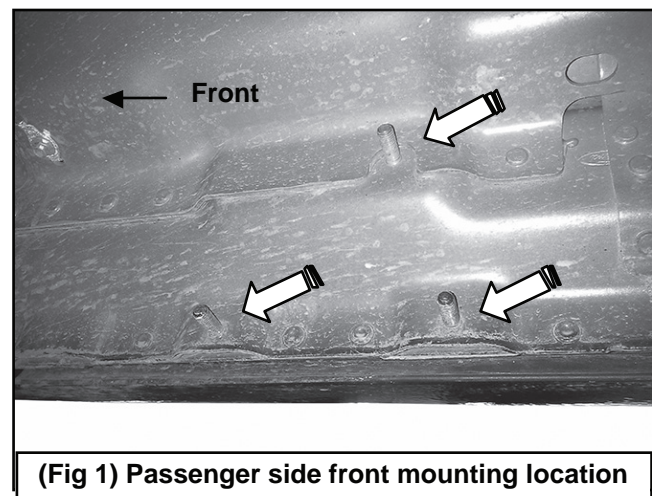



TYGER[®]



(Fig 2) Plastic Insulation Washer

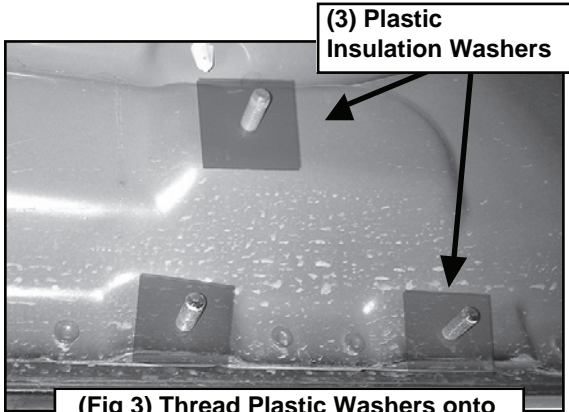

(Fig 3) Thread Plastic Washers onto all mounting studs. Passenger side rear mounting location pictured

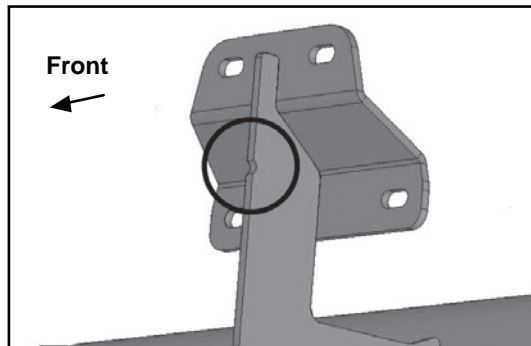

(Fig 4) Locate notch (circled) to identify front Bracket

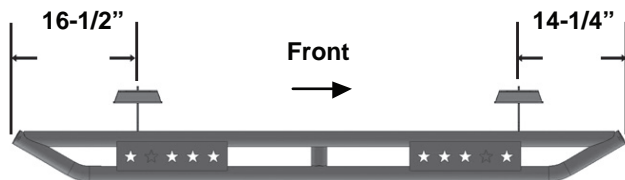

(Fig 5) Select passenger/right Side Armor assembly. Note front bracket is slightly closer to end of tube

(3) 8mm Flat Washers
(3) 8mm Nylon Lock Nuts

(3) 8mm Plastic Washers

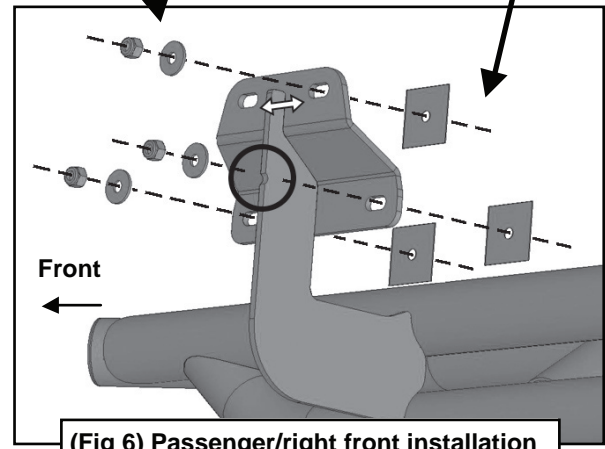

(Fig 6) Passenger/right front installation

STEP 2

Slide (1) Plastic Washer over each of the (3) factory mounting studs in the body panel, (Figures 2, 3 & 6). **IMPORTANT:** The Plastic Washers are designed to prevent corrosion between the aluminum body panel and the steel mounting brackets. Do not install the Brackets without the Plastic Washers.

STEP 3

Select the passenger/right Side Armor assembly, (Figures 4 & 5). **NOTE:** Passenger and driver Side Armor are similar. Front mounting bracket features a notch on the back of the bracket to help identify, (Figure 4). Also, the front bracket is slightly closer to the front end of the tube than the rear bracket, (Figure 5).



TYGER[®]

STEP 4

With assistance, hold the Side Armor assembly up to the vehicle and over the mounting studs and Plastic Washers. Attach the Side Armor to the studs with (6) 8mm Flat Washers and (6) 8mm Nylon Lock Nuts, (Figures 6-8).

(3) 8mm Plastic Washers
(3) 8mm Flat Washers
(3) 8mm Nylon Lock Nuts

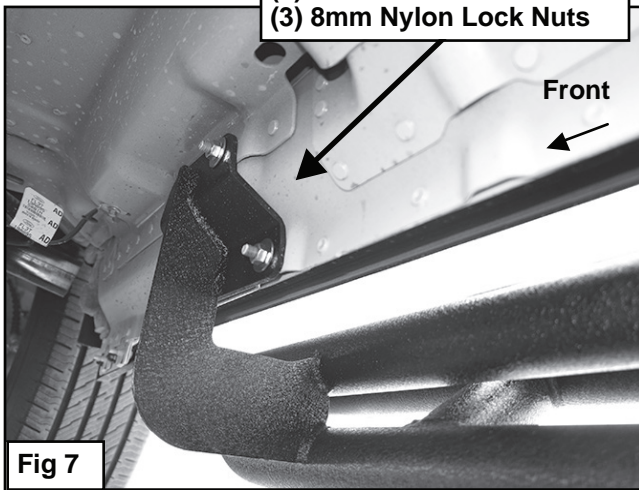

(3) 8mm Plastic Washers
(3) 8mm Flat Washers
(3) 8mm Nylon Lock Nuts

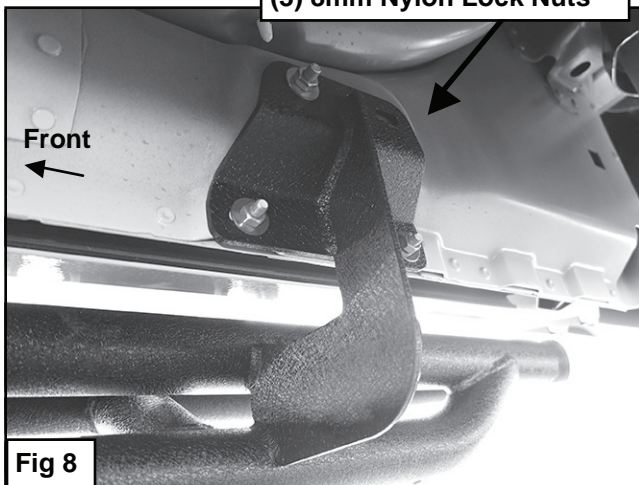

STEP 5

Level and adjust the Side Armor assembly as desired and tighten all hardware.

STEP 6

Repeat Steps 1-5 to install the driver/left Side Armor assembly.

STEP 7

Do periodic inspections to the installation to make sure that all hardware is secure and tight.

