



TYGER®

STAR ARMOR™

BEFORE INSTALLATION

READ INSTRUCTIONS CAREFULLY BEFORE STARTING INSTALLATION. REMOVE CONTENTS FROM BOX AND VERIFY ALL PARTS ARE PRESENT. FAILURE TO IDENTIFY DAMAGE BEFORE INSTALLATION COULD LEAD TO A REJECTION OF ANY CLAIM. IF MISSING PARTS OR ANY DAMAGE FOUND, PLEASE TAKE A PICTURE FOR THE CLAIM PURPOSE.

WARNING

TO PROTECT YOUR INVESTMENT, WAX THIS PRODUCT AFTER INSTALLING. REGULAR WAXING IS RECOMMENDED TO ADD A PROTECTIVE LAYER OVER THE FINISH. DO NOT USE ANY TYPE OF POLISH OR WAX THAT MAY CONTAIN ABRASIVES THAT COULD DAMAGE THE FINISH.

TG-AM2D20638

NOTE: Assistance is recommended for installation.

Parts List

- x1 Driver/left Side Armor Assembly
- x1 Passenger/right Side Armor Assembly
- x18 8mm x 24mm x 2mm Flat Washers
- x18 8-1.25mm Nylon Lock Nuts

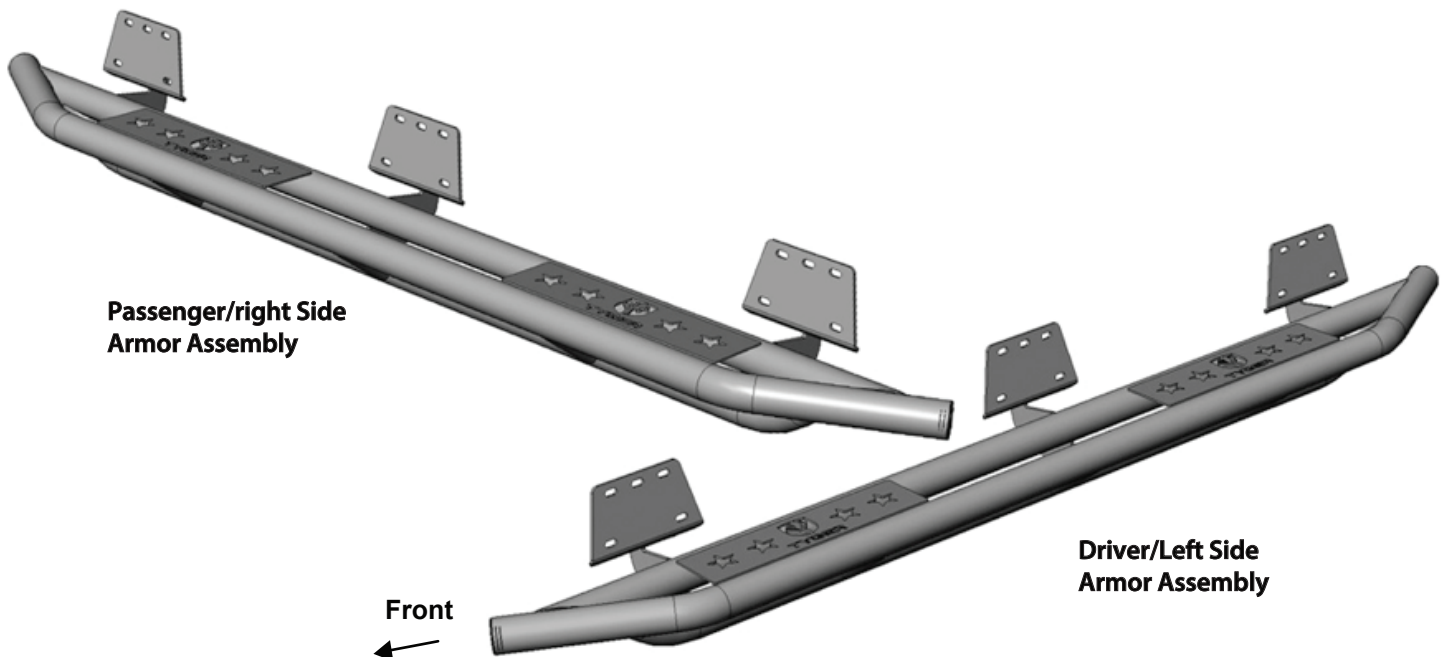



STEP 1

Start the installation under the passenger side of the vehicle. Locate the front (3) factory studs along the inner side of the body panel, (Fig 1). Use a wire brush or thread chaser die to remove excess paint or undercoating from threaded studs as necessary.

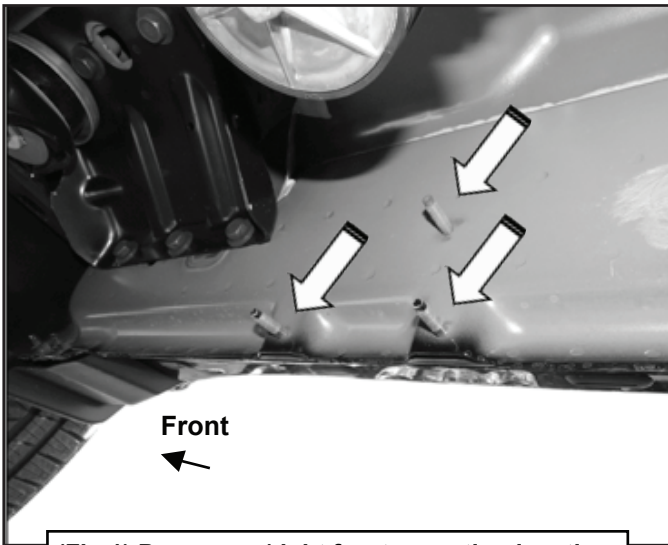

(Fig 1) Passenger/right front mounting location. Remove excess paint or undercoating from all factory threaded studs.

STEP 2

Move along the inner body panel to the center and rear mounting locations and repeat Step 1 to prepare all mounting studs, (Fig 2).

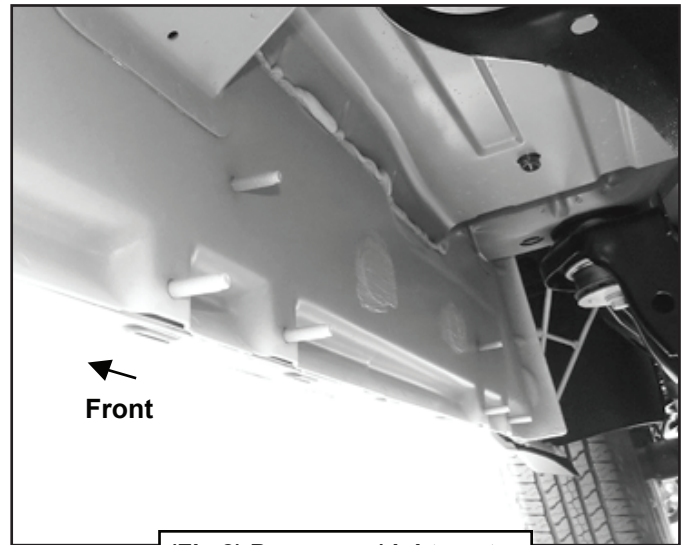

(Fig 2) Passenger/right center and rear mounting locations



STEP 3

Carefully unwrap and select the Passenger/right Side Armor Assembly. Use the illustration above to help identify the correct Side Armor Assembly.

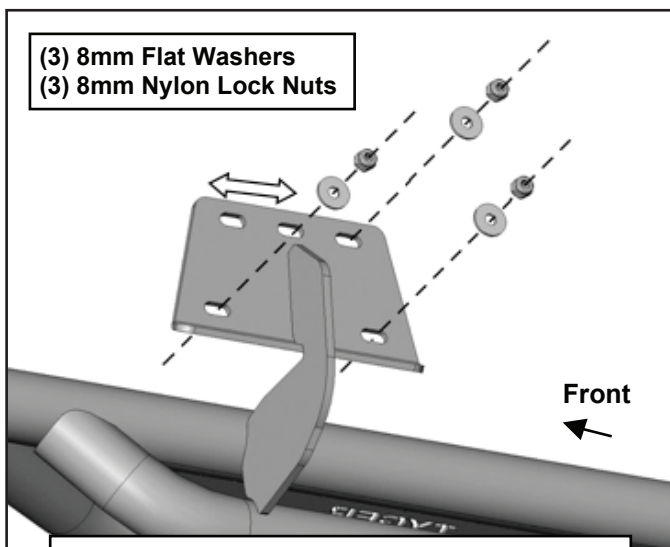

(Fig 3) Attach Mounting Bracket on Side Armor assembly to threaded studs. Passenger/right front installation illustrated for example

STEP 4

With assistance, line up the Side Armor over the mounting studs. Attach the Side Armor Assembly to the (9) factory studs with (9) 8mm Flat Washers and (9) 8mm Nylon Lock Nuts, (Figs 3-6). Leave brackets loose at this time.

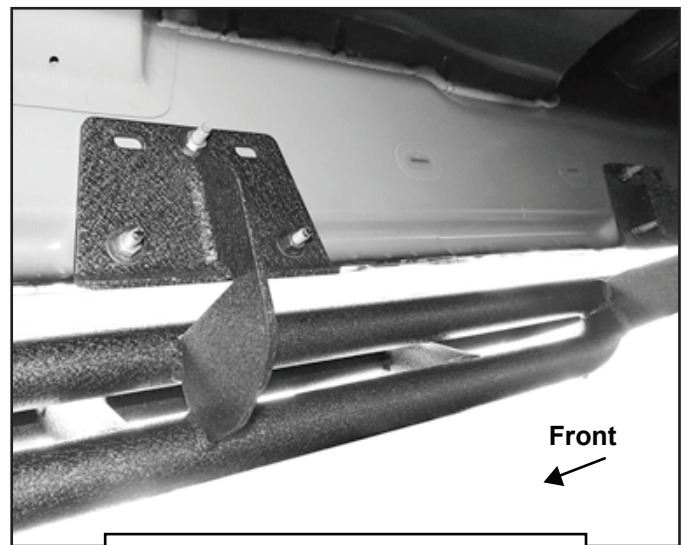

(Fig 5) Passenger/right center installed

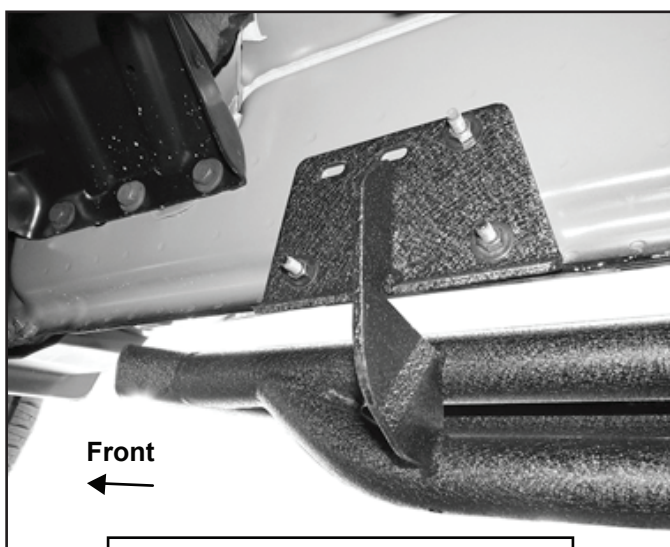

(Fig 4) Passenger/right front installed

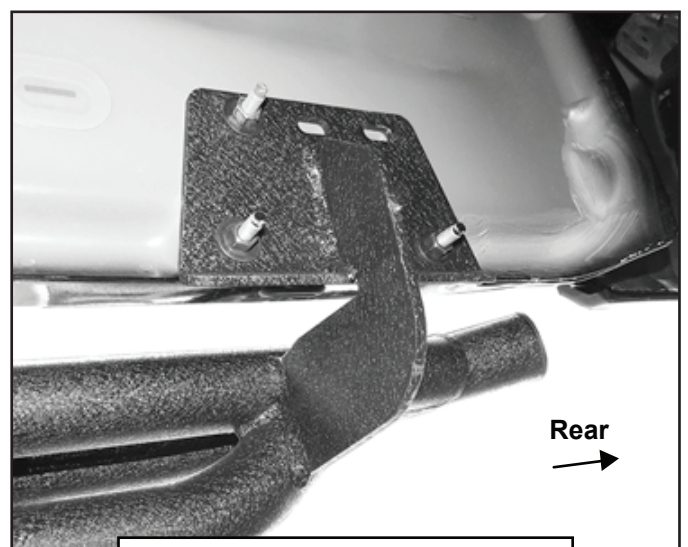

(Fig 6) Passenger/right rear installed



TYGER[®]

STEP 5

Level and adjust the Side Armor as necessary and fully tighten all hardware.

STEP 6

Repeat Steps 1-5 for Driver/left Side Armor installation.

STEP 7

Do periodic inspections to the installation to make sure that all hardware is secure and tight.

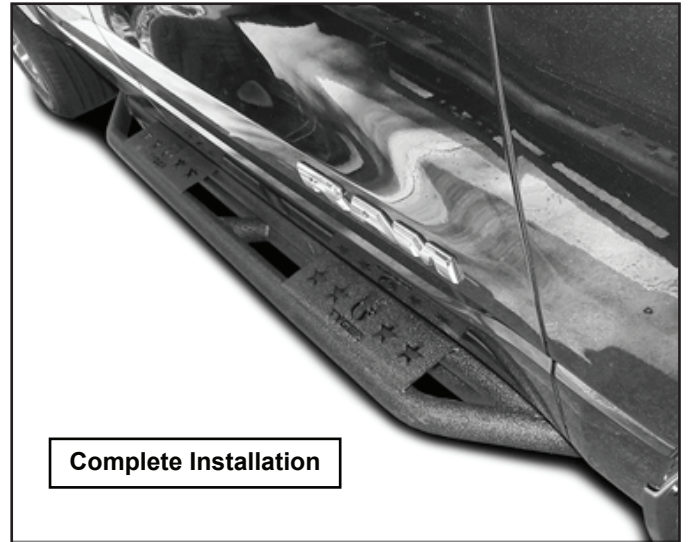

Get in and out of your truck or SUV easier with running boards available on our website.