



# TYGER<sup>®</sup>

TG-AM2D20198

## TYGER ARMOR™

### Parts List

- |   |                                   |                          |
|---|-----------------------------------|--------------------------|
| x1 Driver Side Armor                            | x24 6mm x 22mm x 2mm Flat Washers | x6 8mm Hex Nuts          |
| x1 Passenger Side Armor                         | x6 8mm Nut/Bolt Plates            | x6 8mm Nylon Lock Nuts   |
| x3 Support Brackets (DS Front/Center & PS Rear) | x6 8mm Plastic Retainers          | x12 6mm x 25mm Hex Bolts |
| x3 Support Brackets (PS Front/Center & DS Rear) | x18 8mm-1.25 x 30 Hex Bolts       | x12 6mm Nylon Lock Nuts  |
| x24 8mm x 24mm x 2mm Flat Washers               | x12 8mm Lock Washers              |                          |

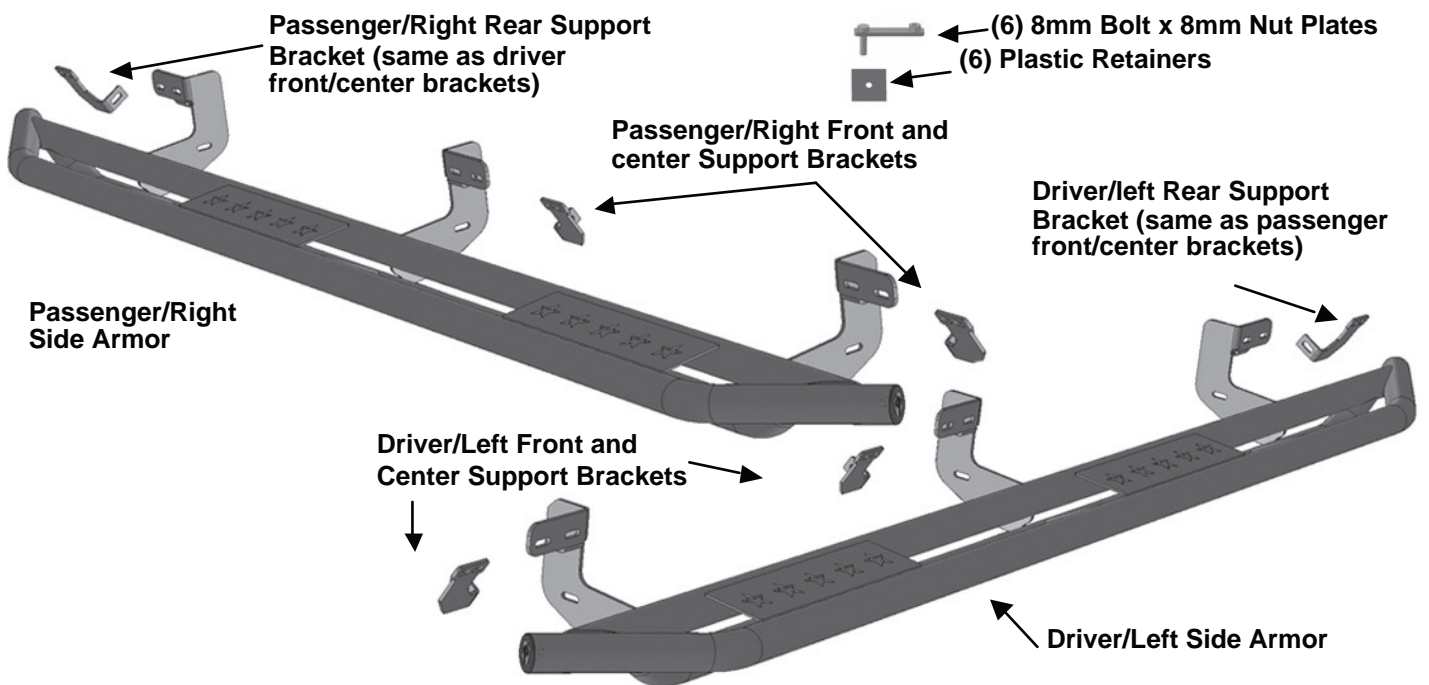



# TYGER<sup>®</sup>

## Before Installation

READ INSTRUCTIONS CAREFULLY BEFORE STARTING INSTALLATION. REMOVE CONTENTS FROM BOX AND VERIFY ALL PARTS ARE PRESENT. ASSISTANCE IS RECOMMENDED. ASSISTANCE IS RECOMMENDED. DRILLING MAY BE REQUIRED.

## Warning

To protect your investment, wax this product after installing. Regular waxing is recommended to add a protective layer over the finish. Do not use any type of polish or wax that may contain abrasives that could damage the finish. Mild soap may be used to clean the Side Armor.

## STEP 1

Starting at the driver side of the vehicle, remove the sealing tape covering the factory holes in the side of the inner panel at the front, center and rear mounting location, (Figures 1-3).

## STEP 2

Determine the correct procedure to attach the Side Armor to your model/year. NOTE: Repeat the applicable procedure for all mounting locations.

### Models without factory threaded inserts in body panel:

**a.** Partially thread an 8mm Hex Bolt into the threaded end of an 8mm Bolt and Nut Plate. Thread the Hex Bolt in until it is flush with the welded nut, (Figures 4 & 5). Use the Hex Bolt as a handle and insert the Bolt and Nut Plate into the oval hole, (Figure 6). Feed the threaded bolt on the Bolt Plate through one of the hex shaped factory holes.

**b.** Thread (1) 8mm Plastic Retainer onto the threaded end and down tight against the body panel, (Figure 7). NOTE: The Plastic Retainer is designed to keep the Bolt/Nut Plate from falling into



(Fig 1) 2009-mid 2015 Driver/Left front mounting location (No factory holes in pinch weld on some models)



(Fig 2) Driver/Left center location



(Fig 3) Driver/Left rear mounting location



(Fig 4) 8mm Bolt-8mm Nut Plate, NOTE: 8mm Bolt-Nut Plate is not required on models with threaded inserts



# TYGER<sup>®</sup>

the body panel and to aid in Bracket installation.

**c.** Repeat to install (1) Bolt/Nut Plate and Retainer in the center and rear mounting locations.

**d.** With assistance, hold the Side Armor up to and over the (3) Bolt/Nut Plates. Attach the (3) Brackets on the Side Armor to the (3) Bolt/Nut Plates with (3) 8mm Flat Washers, (3) 8mm Lock Washers and (3) 8mm Hex Nuts, (Figure 8). Do not tighten at this time.

**e.** Next, remove the 8mm Hex Bolt from the nut on the Bolt Plate in the front location. Rotate the Bolt on the Bolt Plate until the threaded nut lines up with the remaining hole in the Mounting Bracket and body panel, (Figure 8). Attach the Bracket to the threaded Nut Plate with (1) 8mm x 30mm Hex Bolt, (1) 8mm Lock Washer and (1) 8mm Flat Washer, (Figure 9). Do not fully tighten hardware at this time. Repeat to attach the center and rear brackets on the Side Armor.



(Fig 5) Thread (1) 8mm Hex Bolt into the nut on the plate. Stop when bolt reaches end of nut as pictured

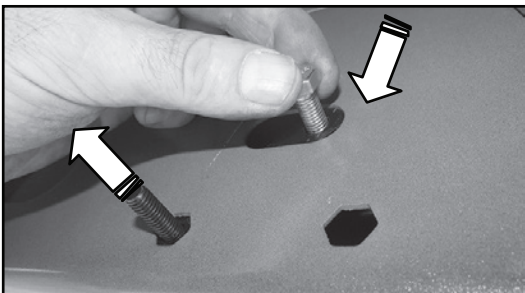

(Fig 6) Use the loose Hex Bolt as a handle. Insert the Bolt Plate into the oval hole and feed the threaded end out either factory hex shaped hole. **IMPORTANT:** Do not let go of the hex bolt until after Plastic Retainer has been threaded onto bolt (Fig 5)

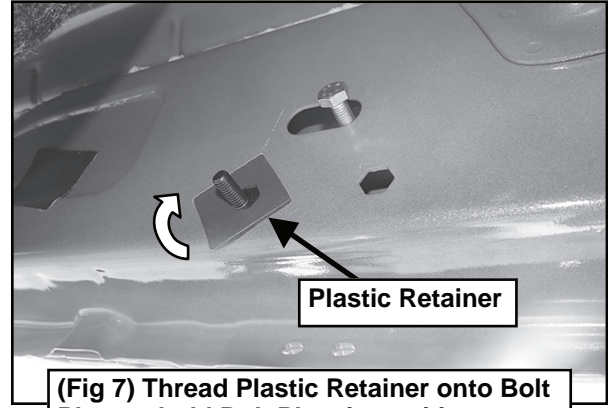

(Fig 7) Thread Plastic Retainer onto Bolt Plate to hold Bolt Plate in position.

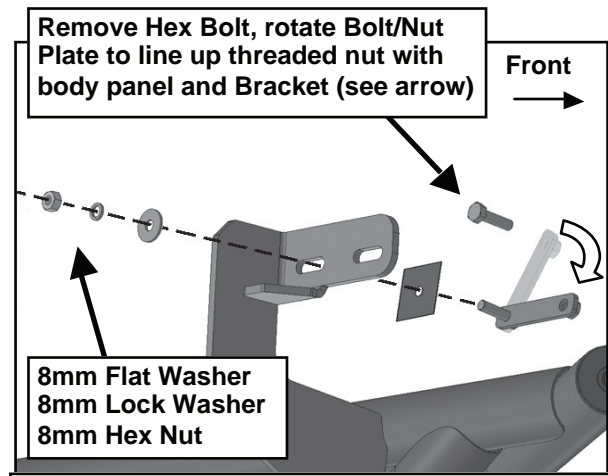

(Fig 8) Attach Side Armor bracket to Bolt Plate

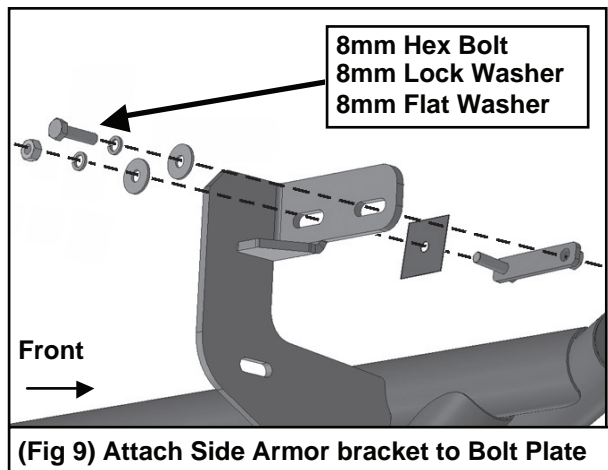

(Fig 9) Attach Side Armor bracket to Bolt Plate



# TYGER®

## Models with factory threaded inserts:

**a.** With assistance, hold the Side Armor up to the threaded inserts in the body. Attach the brackets on the Side Armor to the threaded inserts with (6) 8mm x 30mm Hex Bolts, (6) 8mm Lock Washers and (6) 8mm Flat Washer, (Figures 10 & 11). Leave hardware loose.

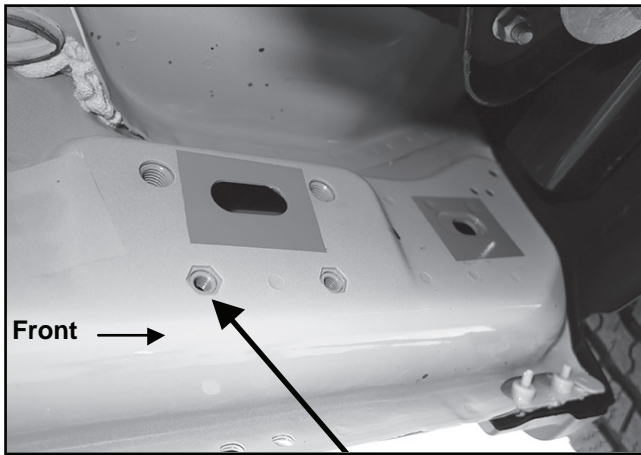

(Fig 10) Driver side front mid 2015-on, an example of models with factory installed threaded inserts

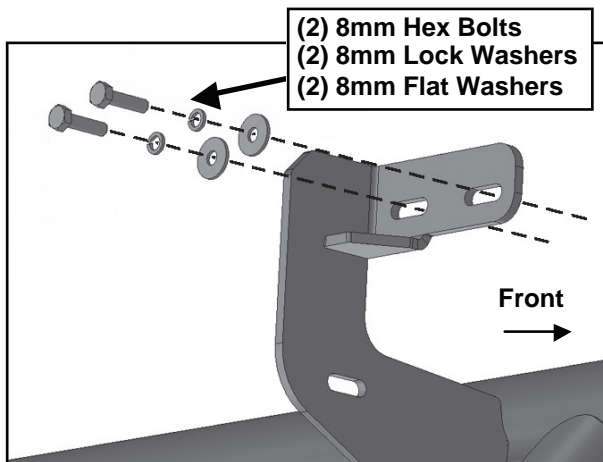

(Fig 11) Driver side front-models with factory installed threaded inserts. Bolt Plate not required

## STEP 3

Next, select (1) driver side front/center Support Bracket, (Figure 12). Attach the Bracket to the front side of the front Bracket with (1) 8mm x 30mm Hex Bolt, (2) 8mm Flat Washers and (1) 8mm Nylon Lock Nut, (Figure 13).

Driver/Left front and center Support Brackets (same as passenger rear Support Bracket)

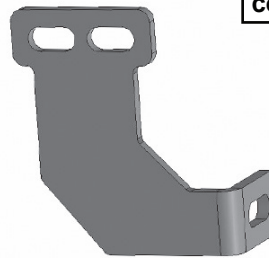
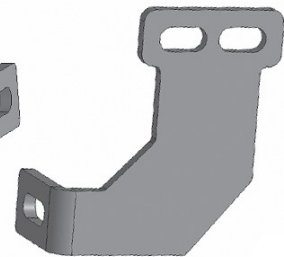
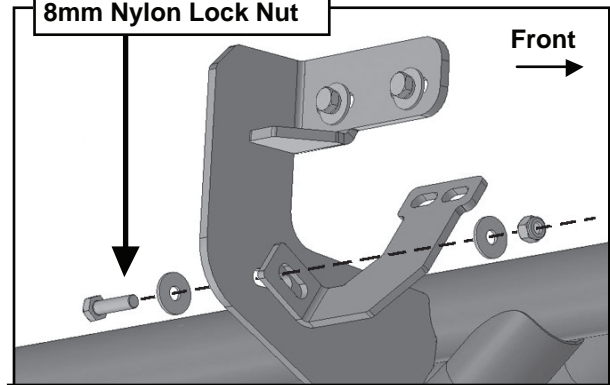

Fig 12

Driver/Left rear Support Bracket (same as passenger front and center Support Brackets)



8mm Hex Bolt  
(2) 8mm Flat Washers  
8mm Nylon Lock Nut



(Fig 13) Attach Driver/Left front and center Support Brackets to front facing side of Bracket





# TYGER<sup>®</sup>

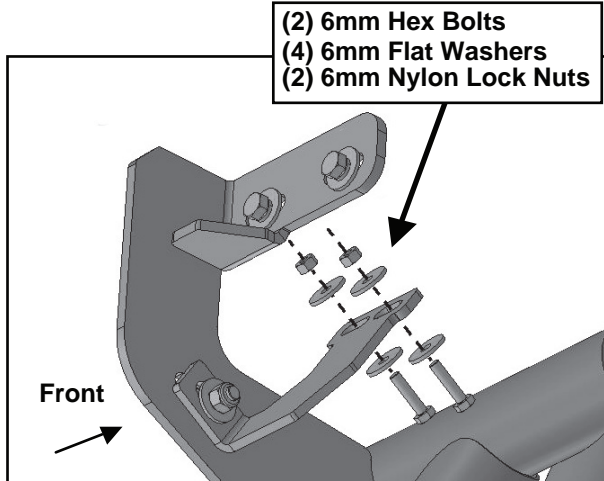

(Fig 14) Attach Support Bracket to back of pinch weld

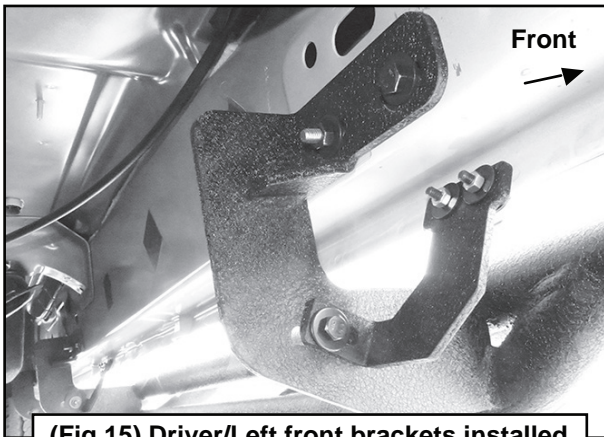

(Fig 15) Driver/Left front brackets installed

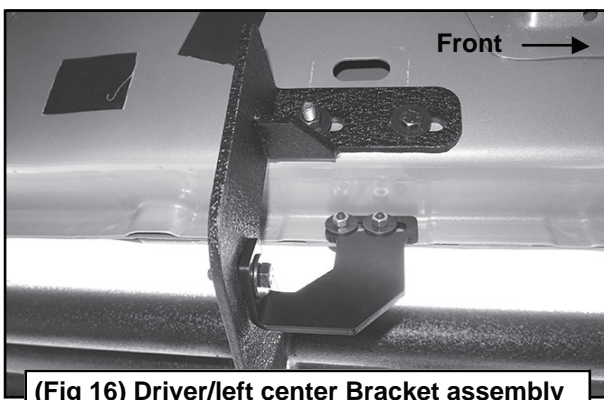

(Fig 16) Driver/left center Bracket assembly

## STEP 4

Rotate the Support Bracket to the back of the pinch weld. Line up the slots in the top of the Support Bracket with the (2) factory holes in the pinch weld. Attach the Bracket to the back of the pinch weld with (2) 6mm x 25mm Hex Bolts, (4) 6mm Flat Washers and (2) 6mm Nylon Lock Nuts, (Figures 14 & 15). Do not fully tighten hardware at this time. **IMPORTANT:** Some models are not equipped with factory holes and will require drilling through the pinch weld to attach the Support Bracket. Do not drill through pinch weld at this time, (see Step 7).

## STEP 5

Move along the side of the body panel to the center mounting location. Repeat Steps 3-4 to install the driver side center Bracket, (Figure 16). **IMPORTANT:** The front and center brackets are different from the rear Support Bracket, (see illustration above-note direction of mounting plate).

## STEP 6

Move to the rear location. Repeat Step 5 to attach the rear Support Bracket to the back of the side armor bracket, (Figure 17).

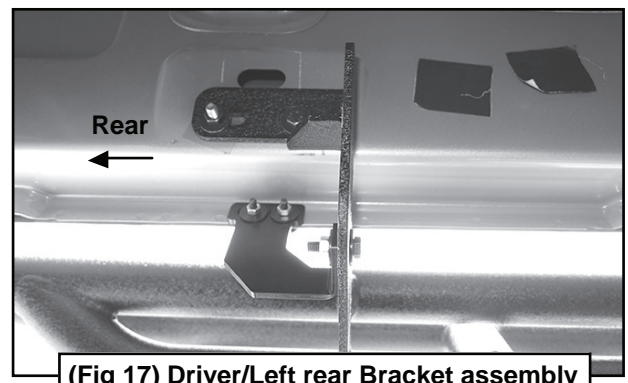

(Fig 17) Driver/Left rear Bracket assembly



# TYGER®

## STEP 7

Properly level and adjust the Sidebar and fully tighten all hardware.

### Some models requiring drilling for driver side Support Brackets

- a. Make sure the Side Armor is level to the vehicle. Adjust and tighten all mounting hardware.
- b. Line up the slots on the Support Brackets with the back of the pinch weld. Mark the location of the slots onto the pinch weld.
- c. Drill (2) 1/4" holes through the pinch weld for each Support Bracket. **IMPORTANT:** Do not drill too close to the bottom edge of the pinch weld. Adjust the Brackets as necessary to move the slots up the body panel away from the edge. Drill the holes toward the outside of the marked slots.
- d. Attach each Support Bracket to the pinch weld with (2) 6mm Hex Bolts, (4) 6mm Flat Washers and (2) 6mm Nylon Lock Nuts, (Figures 14-17).
- e. Do periodic inspections to the installation to make sure that all hardware is secure and tight.

**IMPORTANT:** Some models without holes in pinch weld will require drilling 1/4" holes through pinch weld to attach driver side front support bracket. Do complete installation of side armors first, level side armor before drilling holes for support bracket.

## STEP 8

Move to the passenger side of the vehicle. Remove tape covering front, center and rear locations. Repeat Steps 1-7 for passenger side installation.

## STEP 9

Do periodic inspections to the installation to make sure that all hardware is secure and tight.



Installation Complete