



# TYGER<sup>®</sup>

TG-AM2D20088

## TYGER ARMOR™

### Parts List

|   |   |                              |
|---|---|------------------------------|
| x1 Driver Side Armor                      | x1 Passenger/Right Rear Support Bracket | x6 10mm Plastic Retainers    |
| x1 Passenger Side Armor                   | x6 12-1.75mm x 120mm Gr.10.9 Hex Bolts  | x6 10mm x 35mm Bolt Plates   |
| x1 Driver/Left Front Support Bracket      | x6 12mm x 32mm OD x 3mm Flat Washers    | x6 10mm Lock Washers         |
| x1 Passenger/Right Front Support Bracket  | x6 10mm x 30mm OD x 2.5mm Flat Washers  | x6 10mm Hex Nuts             |
| x1 Driver/Left Center Support Bracket     | x16 8mm x 24mm OD x 2mm Flat Washers    | x8 8-1.25mm x 25mm Hex Bolts |
| x1 Passenger/Right Center Support Bracket | x6 14mm Large Spacers                   | x8 8mm Lock Washers          |
| x1 Driver/Left Rear Support Bracket       | x6 12mm Lock Washers                    | x8 8mm Hex Nuts              |

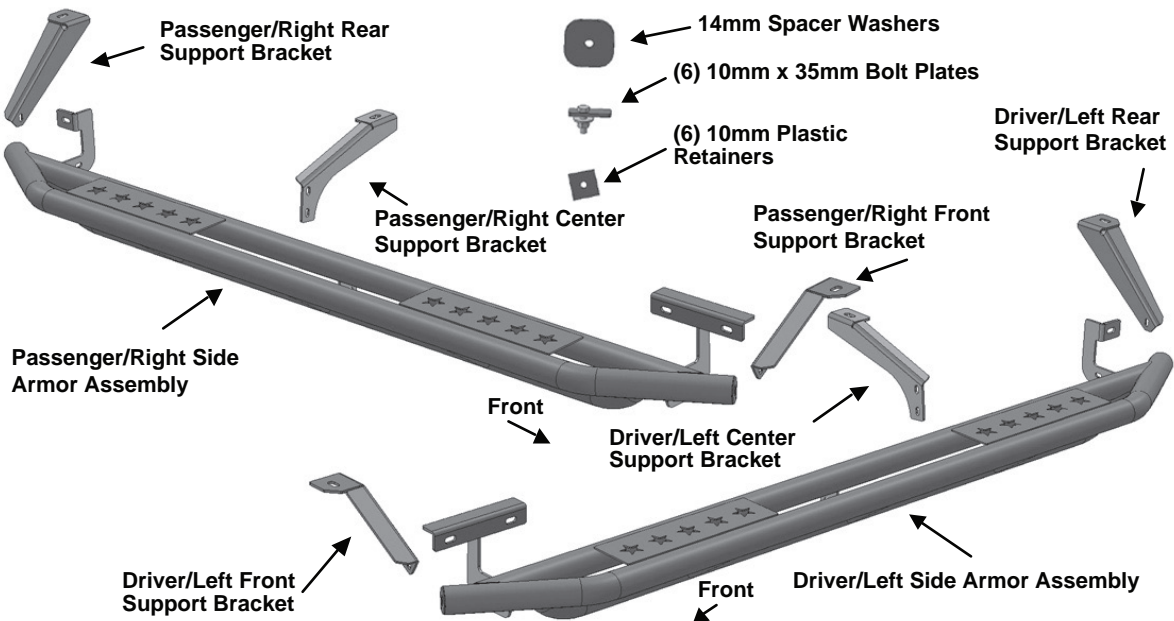



# TYGER<sup>®</sup>

## Before Installation

REMOVE CONTENTS FROM BOX. VERIFY ALL PARTS ARE PRESENT. READ INSTRUCTIONS CAREFULLY BEFORE STARTING INSTALLATION. ASSISTANCE IS HIGHLY RECOMMENDED.

## Warning

To protect your investment, wax this product after installing. Regular waxing is recommended to add a protective layer over the finish. Do not use any type of polish or wax that may contain abrasives that could damage the finish. Mild soap may be used to clean the Side Armor.

## STEP 1

Start installation toward the front of the passenger/right side of the vehicle. Locate the (2) factory holes in the back side of the rocker panel closest to the front wheel opening, (Figure 1). NOTE: The mounting locations may be covered with sealing tape and/or undercoating. Remove tape and undercoating as necessary.

Remove sealing tape to uncover mounting holes

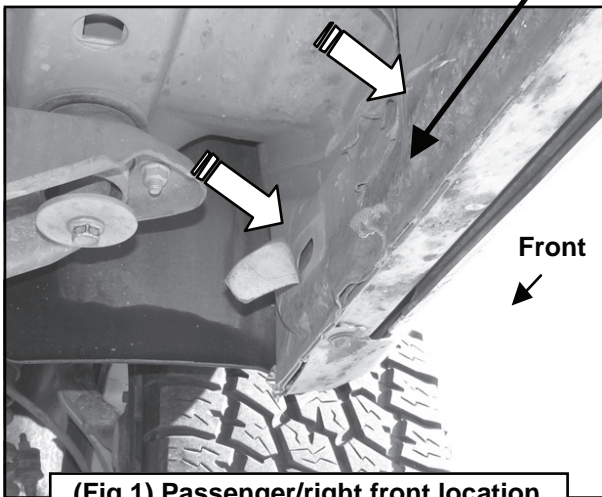

## STEP 2

Thread (1) Plastic Retainer part way onto (1) 10mm x 35mm Bolt Plate, (Figure 2). Insert the Bolt Plate into the forward factory hole in the rocker panel, (Figure 3). Hold the Bolt Plate in place with one hand and continue to thread the Plastic Retainer down against the sheet metal until it holds the Bolt Plate in place. Repeat to insert the 2nd Bolt Plate and Retainer in the 2nd mounting hole, (Figure 3). IMPORTANT: The Plastic Retainer is designed to prevent the Bolt Plate from falling into the body panel and to aid Side Armor installation.



(Fig 2) 10mm Bolt Plate with Retainer



## STEP 3

Next, move to the rear mounting location. Remove the tape covering the last factory hole in the inner rocker panel at the back of the cab, (Figure 4). Insert (1) Bolt Plate into the mounting hole in the body as described in Steps 1 & 2, (Figure 5).



# TYGER<sup>®</sup>

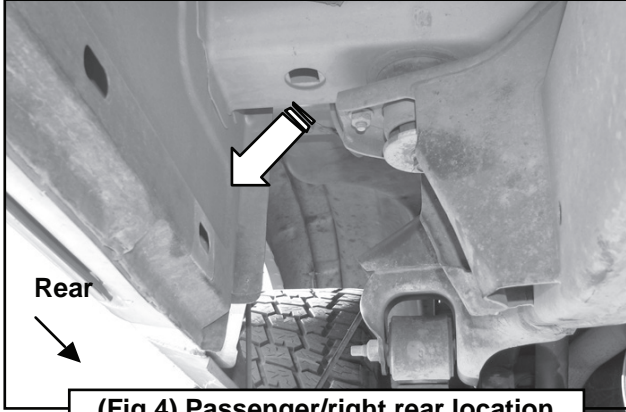

(Fig 4) Passenger/right rear location

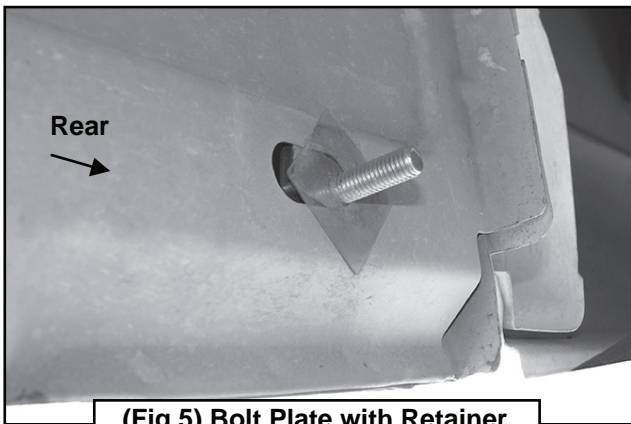

(Fig 5) Bolt Plate with Retainer

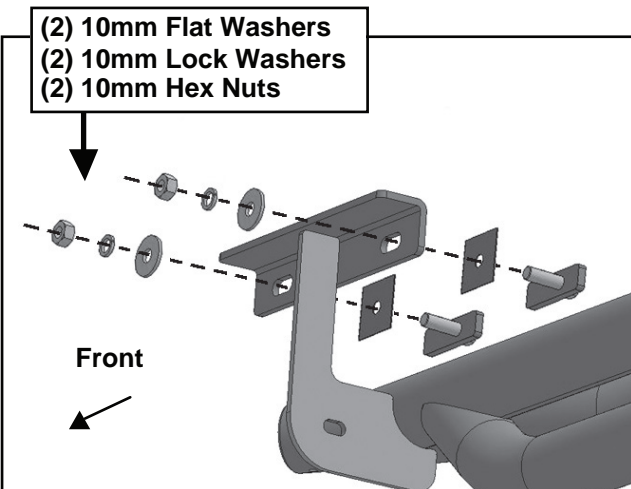

(Fig 6) Attach front Bracket to Bolt Plates

## STEP 4

With assistance, carefully position the passenger/right Side Armor up to the (3) Bolt Plates. Attach the brackets on the Side Armor to the Bolt Plates with (3) 10mm Flat Washers, (3) 10mm Lock Washers and (3) 10mm Hex Nuts, (Figures 6 & 7). Snug but do not fully tighten hardware at this time.

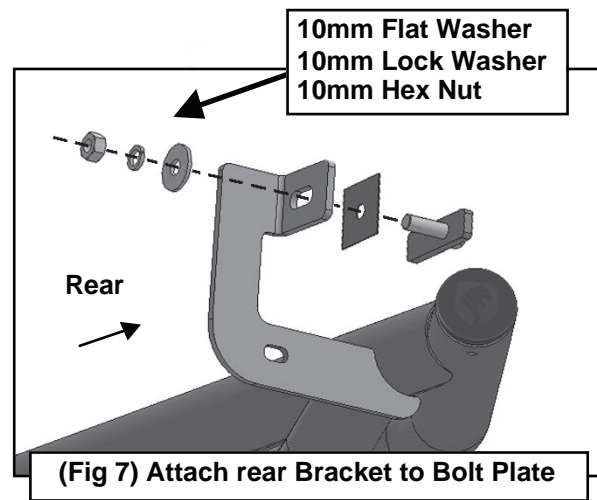

(Fig 7) Attach rear Bracket to Bolt Plate

## STEP 5

Move to the passenger/right front body mount. Remove the factory body mount bolt and flat washer, (Figure 8). Remove but do not discard the factory rubber bushing from the body bolt.

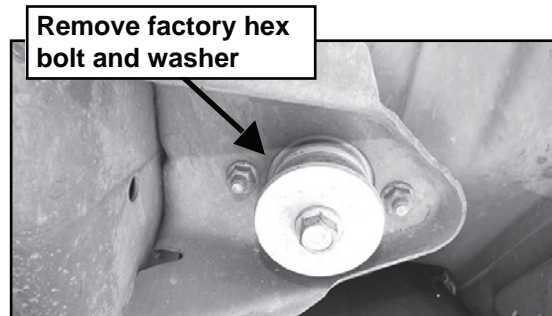

(Fig 8) 2005-up with removable washer pictured



# TYGER<sup>®</sup>

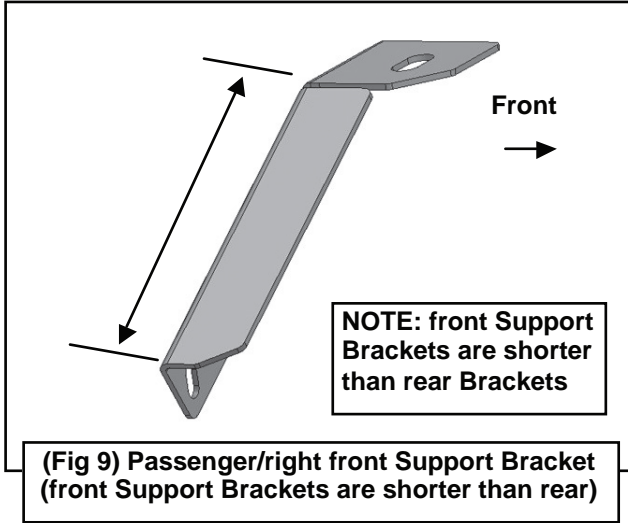

(Fig 9) Passenger/right front Support Bracket  
(front Support Brackets are shorter than rear)

Spacer  
12mm x 120mm Hex Bolt  
12mm Lock Washer  
12mm Flat Washer

8mm x 25mm Hex Bolt  
(2) 8mm Flat Washers  
8mm Lock Washer  
8mm Hex Nut

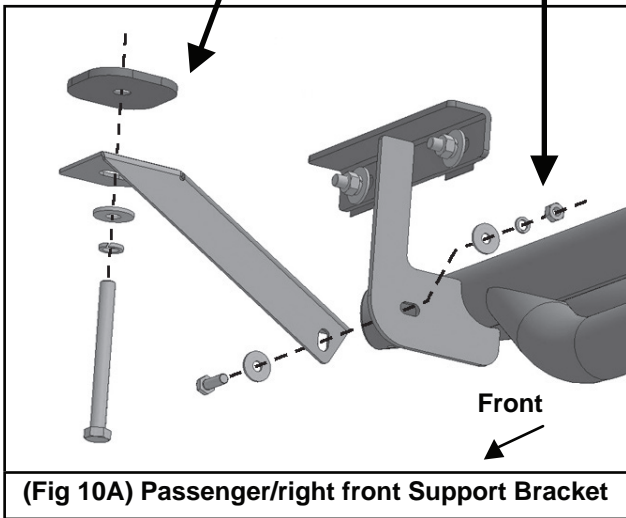

**IMPORTANT:** Models with non-removable washer on body bolt, (up to 2005), insert (1) Steel Spacer between each Support Bracket and factory rubber bushing

## STEP 6

Select the passenger/right front Support Bracket, (Figure 9). Insert (1) 12mm x 120mm Hex Bolt with (1) 12mm Lock Washer and (1) 12mm Flat Washer through the Support Bracket. Place (1) 14mm Large Spacer onto the Hex Bolt and against the Bracket, (Figure 10A). Slide the rubber bushing onto the Hex Bolt and over the Spacer. Make sure that the Spacer is between the Mounting Bracket and the factory rubber bushing, (Figures 10A & 10B). Attach the Support Bracket to the body mount but do not tighten hardware at this time. **IMPORTANT:** On 2005 and newer model years, the large washer on the factory body mount bolt is removable, (do not discard-can reinstall), and the bolt is long enough to go through the Mounting Bracket and properly thread into the body mount. It is the installer's responsibility to check length and to determine whether to use the factory body bolt and washer or the included 12mmx120mm Hex Bolt and Spacer.



(Fig 10B) Passenger/right front Support Bracket

## STEP 7

Attach the lower end of the Support Bracket to the front of the front bracket on the Side Armor assembly with (1) 8mm x 25mm Hex Bolt, (2) 8mm Flat Washers, (1) 8mm Lock Washer and (1) 8mm Hex Nut, (Figures 10A & 10B). Snug but do not tighten hardware at this time.



# TYGER®

## STEP 8

Move to the center mounting location. Remove the factory body mount bolt. Remove but do not discard the factory rubber bushing from the factory bolt. Select the passenger/right Center Support Bracket, (Figure 11). Repeat Step 6 to attach the top of the Center Support Bracket to the body mount, (Figure 12). Attach the lower end of the Support Bracket to the back of the mounting tab on the Side Armor with (2) 8mm x 25mm Hex Bolts, (4) 8mm Flat Washers, (2) 8mm Lock Washers and (2) 8mm Hex Nuts, (Figure 12). Leave loose at this time.

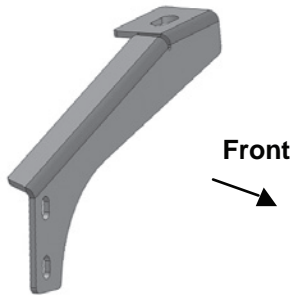

(Fig 11) Passenger/right center Support Bracket

|   |  |
|---|--|
| Spacer<br>12mm x 120mm Hex Bolt<br>12mm Lock Washer<br>12mm Flat Washer | (2) 8mm x 25mm Hex Bolts<br>(4) 8mm Flat Washers<br>(2) 8mm Lock Washers<br>(2) 8mm Hex Nuts |
|---|--|

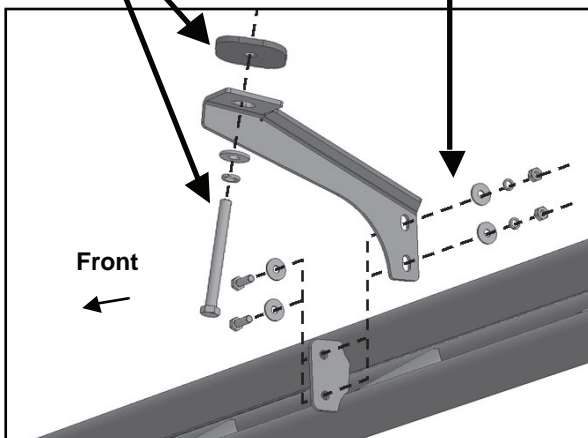

(Fig 12) Passenger/right center Support Bracket

## STEP 9

Move to the rear mounting location. Select the passenger/right rear Support Bracket, (Figure 13). Repeat Steps 5-7 to attach the Support Bracket to the rear facing side of the bracket on the Side Armor, (Figures 14A & 14B).

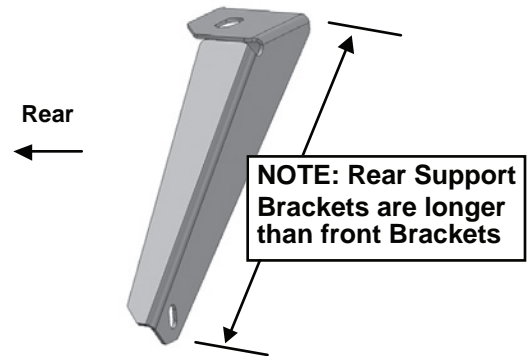

(Fig 13) Passenger/right rear Support Bracket

|   |   |
|---|---|
| Spacer<br>12mm x 120mm Hex Bolt<br>12mm Lock Washer<br>12mm Flat Washer | 8mm x 25mm Hex Bolt<br>(2) 8mm Flat Washers<br>8mm Lock Washer<br>8mm Hex Nut |
|---|---|

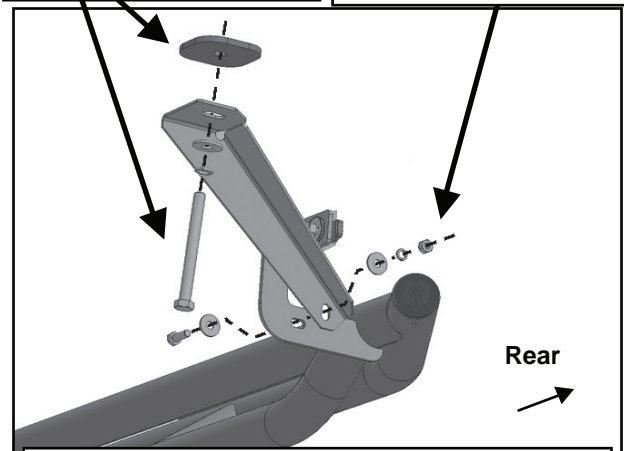

(Fig 14A) Passenger/right rear Support Bracket

**IMPORTANT:** Models with non-removable washer on body bolt, (up to 2005), insert (1) Steel Spacer between each Support Bracket and factory rubber bushing



# TYGER®

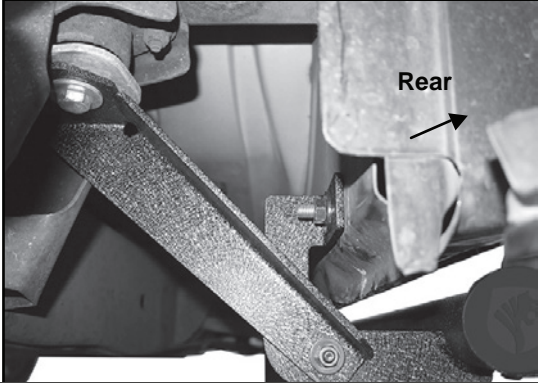

**(Fig 14B) Passenger/right rear Support Bracket**

## STEP 10

Properly level and adjust the Side Armor and tighten all hardware at this time.

## STEP 11

Repeat Steps 1-10 for the driver/left Side Armor installation.

## STEP 12

Do periodic inspections to the installation to make sure that all hardware is secure and tight.

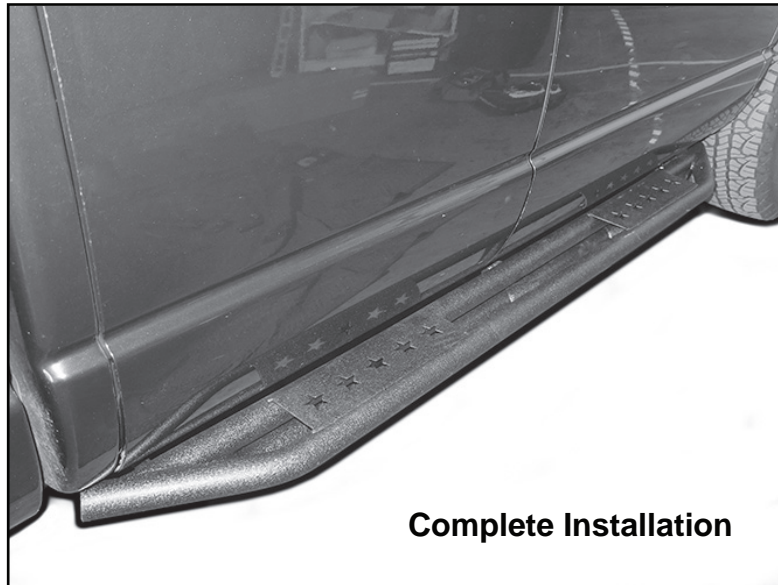

**Complete Installation**