



TYGER[®]

TG-AM2D20038

TYGER ARMOR

Parts List

- | | | |
|---|-----------------------------|-----------------------------------|
| x1 Driver Side Armor | x18 8mm-1.25 x 30 Hex Bolts | x6 8mm Nylon Lock Nuts |
| x1 Passenger Side Armor | x6 8mm Nut/Bolt Plates | x12 6mm x 25mm Hex Bolts |
| x3 Support Brackets (DS Front/Center & PS Rear) | x6 8mm Plastic Retainers | x24 6mm x 22mm x 2mm Flat Washers |
| x3 Support Brackets (PS Front/Center & DS Rear) | x12 8mm Lock Washers | x12 6mm Nylon Lock Nuts |
| x24 8mm x 24mm x 2mm Flat Washers | x6 8mm Hex Nuts | |

Before Installation

REMOVE CONTENTS FROM BOX. VERIFY ALL PARTS ARE PRESENT. READ INSTRUCTIONS CAREFULLY BEFORE STARTING INSTALLATION. DRILLING MAY BE REQUIRED.

Warning

To protect your investment, wax this product after installing. Regular waxing is recommended to add a protective layer over the finish. Do not use any type of polish or wax that may contain abrasives that could damage the finish. Please use only mild soap to clean the Side Armor.

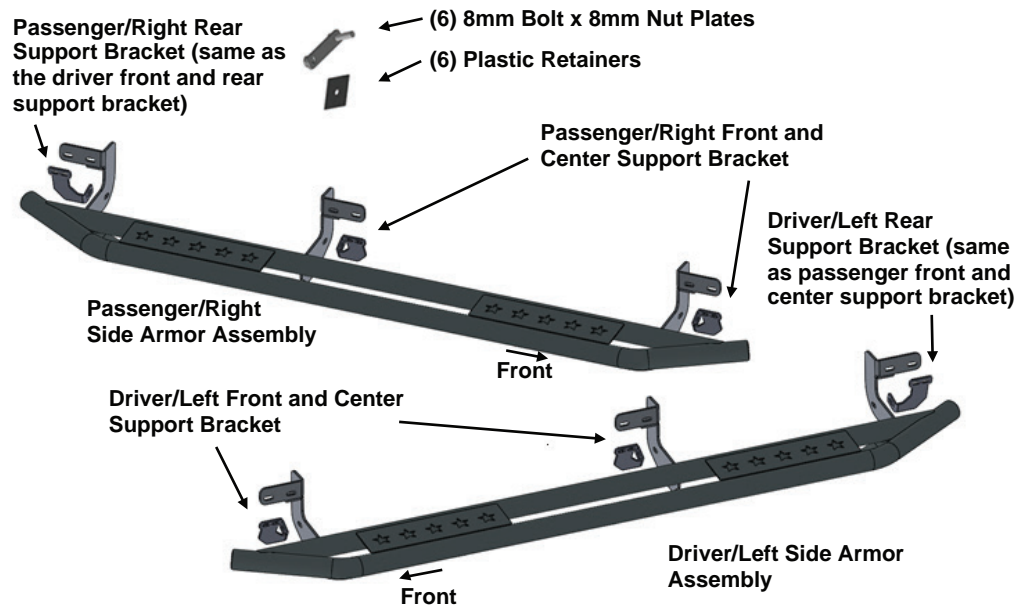



TYGER[®]

STEP 1

Starting at the driver/left side of the vehicle, remove the sealing tape covering the factory holes in the side of the inner panel, (Figure 1). If necessary, line up the driver/left Side Armor with the mounting holes in the body panel to help determine correct mounting locations.

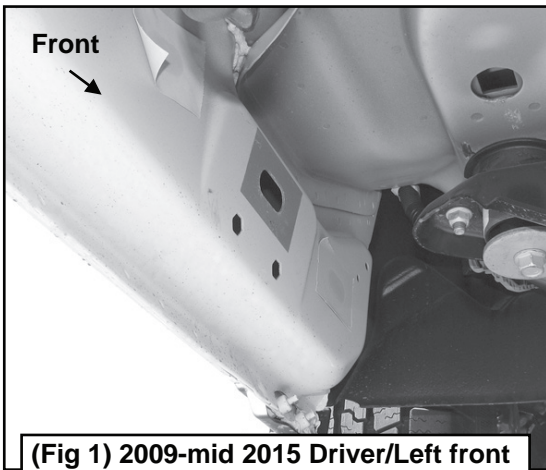

(Fig 1) 2009-mid 2015 Driver/Left front mounting location (No factory holes in pinch weld on some models)

STEP 2

Determine the correct procedure to attach the each of the driver side brackets for your model/year:

Models without factory threaded inserts in body panel

a. Starting with the driver side front mounting location, partially thread an 8mm Hex Bolt into the threaded end of an 8mm Bolt and Nut Plate, (Figure 2). Thread the Hex Bolt in until it is flush with the welded nut, (Figure 3). Use the Hex Bolt as a handle and insert the Bolt and Nut Plate into the oval hole, (Figure 4). Feed the threaded bolt on the Bolt Plate through one of the hex shaped factory holes. Thread (1) 8mm Plastic Retainer onto the threaded end and down tight against the body panel, (Figure 5). NOTE: The Plastic Retainer is designed to keep the Bolt/Nut Plate from falling into the



(Fig 2) 8mm Bolt-8mm Nut Plate, NOTE: 8mm Bolt-Nut Plate is not required on models with threaded inserts

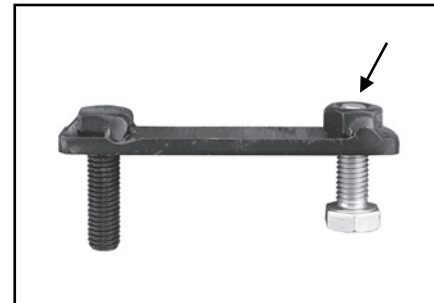

(Fig 3) Thread (1) 8mm Hex Bolt into the nut on the plate. Stop when bolt reaches end of nut as pictured

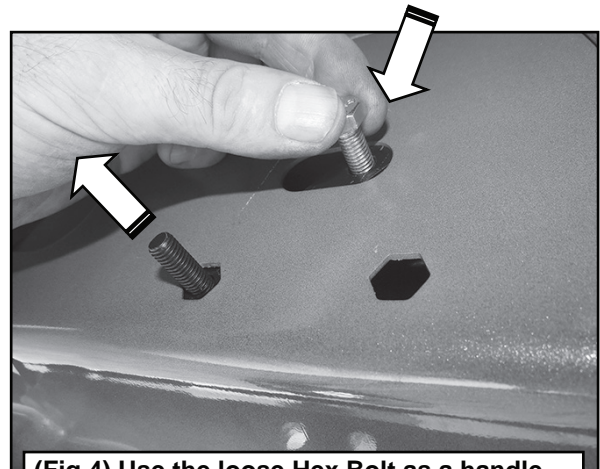

(Fig 4) Use the loose Hex Bolt as a handle. Insert the Bolt Plate into the oval hole and feed the threaded end out either factory hex shaped hole. IMPORTANT: Do not let go of the hex bolt until after Plastic Retainer has been threaded onto bolt (Fig 5)



TYGER[®]

body panel and to aid in Bracket installation. **IMPORTANT:** Repeat for the center and rear mounting location.

b. With assistance, hold the Side Armor up in position.

c. Attach the front Bracket to the threaded end of the Bolt Plate with (1) 8mm Flat Washer, (1) 8mm Lock Washer and (1) 8mm Hex Nut, (Figure 6). Repeat for the center and rear brackets. Do not tighten at this time.

d. Remove the 8mm Hex Bolt from the nut on the Bolt Plate from Step 2a. Rotate the Bolt on the Bolt Plate until the threaded nut lines up with the remaining hole in the Mounting Bracket and body panel, (Figures 6 & 7). Attach the Bracket to the threaded Nut Plate with (1) 8mm x 30mm Hex Bolt, (1) 8mm Lock Washer and (1) 8mm Flat Washer, (Figure 7). Repeat for the center and rear brackets. Do not fully tighten hardware at this time.

Models with factory threaded inserts

a. With assistance, hold the Side Armor up in position. Attach the driver side brackets to the threaded inserts with (6) 8mm x 30mm Hex Bolts, (6) 8mm Lock Washers and (6) 8mm Flat Washer, (Figures 8 & 9). Leave hardware loose.

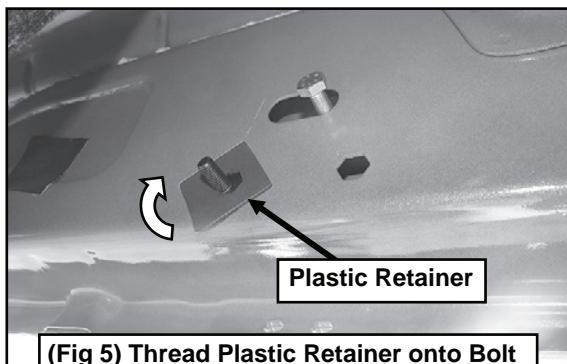

STEP 3

Next, select the driver side front/center Support Bracket. Attach the Bracket to the front facing side of the front Bracket with (1) 8mm x 30mm Hex Bolt, (2) 8mm Flat Washers and (1) 8mm

Nylon Lock Nut, (Figure 10). Rotate the Support Bracket to the back of the pinch weld. Line up the slots in the top of the Support Bracket with the (2) factory holes in the pinch weld. Attach the Bracket to the back of the pinch weld with (2) 6mm x 25mm Hex Bolts, (4) 6mm Flat Washers and (2) 6mm Nylon Lock Nuts, (Figure 10). Do not fully tighten hardware at this time. **IMPORTANT:** Some models are not equipped with factory holes and will require drilling through the pinch weld to attach the Support Bracket. Do not drill through pinch weld at this time, (see Step 6).

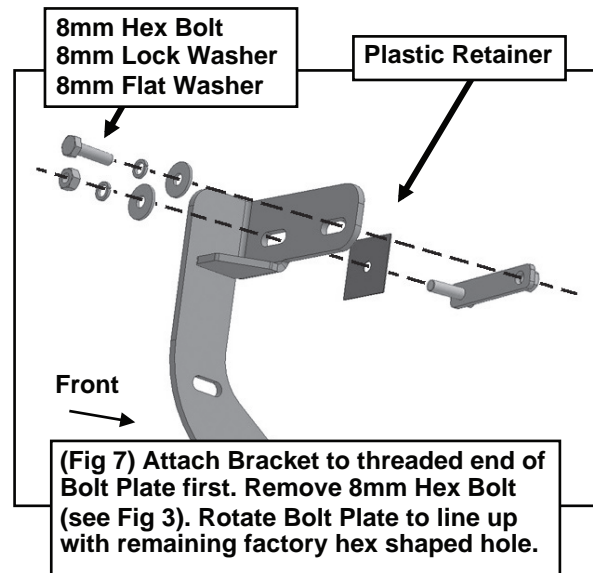
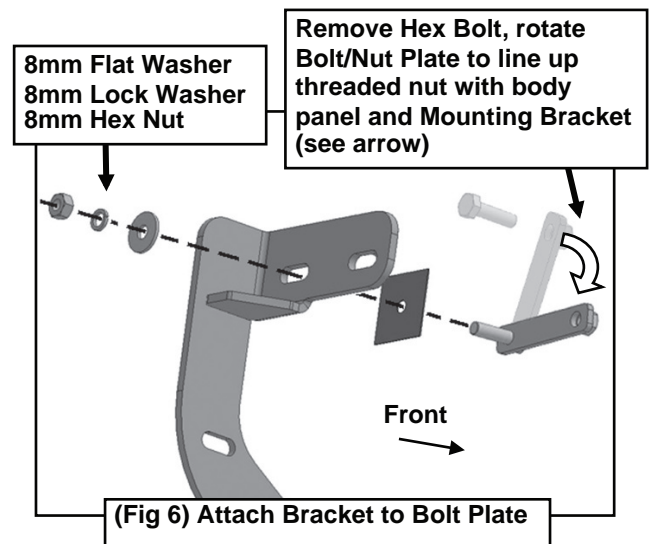



TYGER[®]

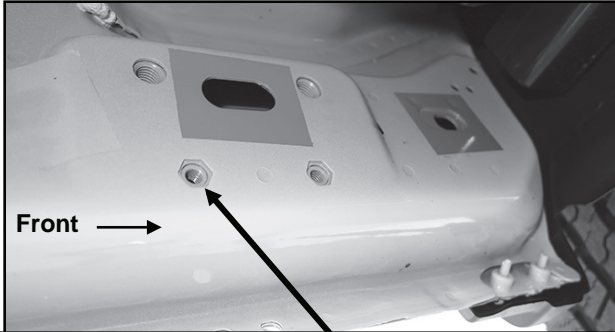

(Fig 8) Driver side front mid 2015-on, an example of models with factory installed threaded inserts

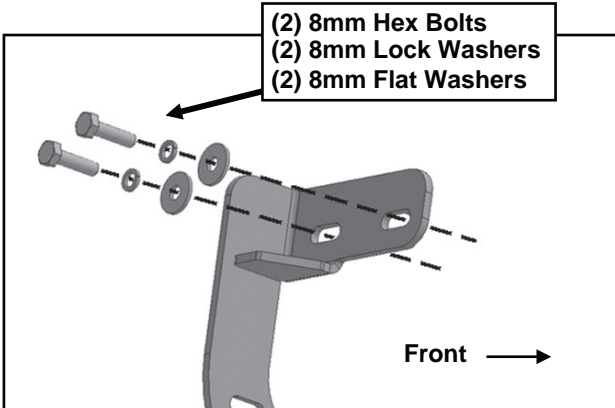

(Fig 9) Driver side front-models with factory installed threaded inserts. Bolt Plate not required

STEP 4

Move along the side of the body panel to the center mounting location, (Figure 11). Repeat Step 3 to install the driver side front/center Support Bracket, (Figures 12).

STEP 5

Move to rear location, (Figure 13). Repeat Step 3 to attach the driver side rear Support Bracket to the back of the rear bracket and holes, (if equipped), in the pinch weld, (Figure 14).

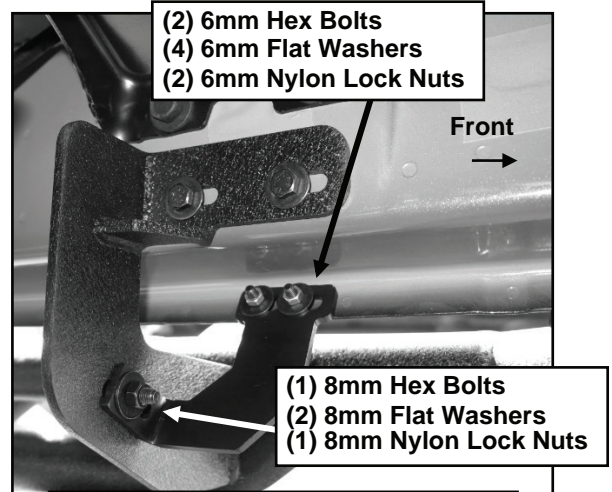

(Fig 10) Driver side front bracket

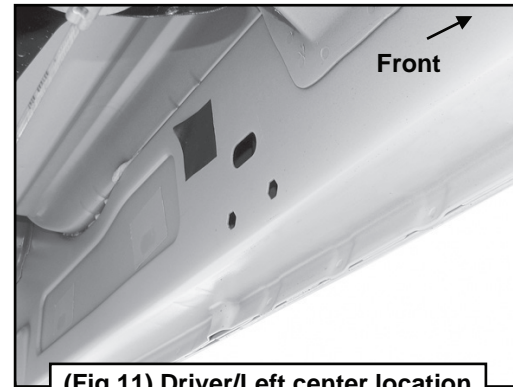

(Fig 11) Driver/Left center location

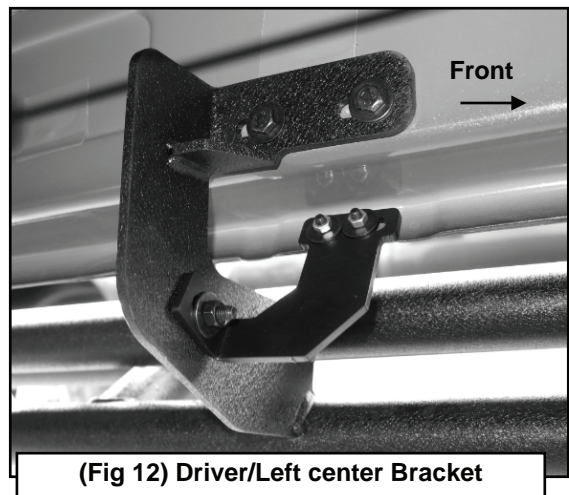

(Fig 12) Driver/Left center Bracket



TYGER[®]

STEP 6

Properly level and adjust the Side Armor and fully tighten all hardware:

Some models requiring drilling for driver side Support Brackets

- Make sure the Side Armor is level to the vehicle. Adjust and tighten all mounting hardware.
- Line up the slots on the Support Brackets with the back of the pinch weld. Mark the location of the slots onto the pinch weld.
- Drill (2) 1/4" holes through the pinch weld for each Support Bracket. **IMPORTANT:** Do not drill too close to the bottom edge of the pinch weld. Adjust the Brackets as necessary to move the slots up the body panel away from the edge. Drill the holes toward the outside of marked slots.
- Attach each Support Bracket to the pinch weld with (2) 6mm Hex Bolts, (4) 6mm Flat Washers and (2) 6mm Nylon Lock Nuts, (Figures 10, 12, 14). Check the Side Armor for level then fully tighten all hardware.

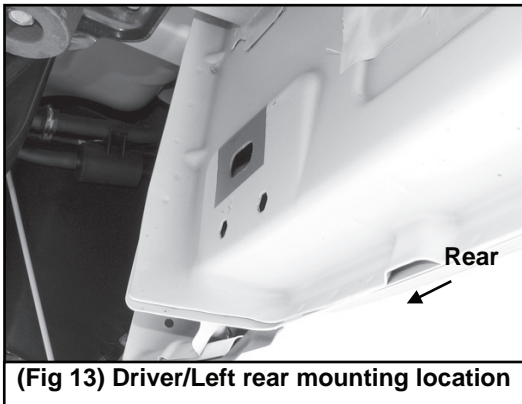

(Fig 13) Driver/Left rear mounting location

STEP 7

Move to the passenger side of the vehicle. Remove tape covering front, center and rear locations. Repeat Steps 1-6 for passenger Side Armor installation.

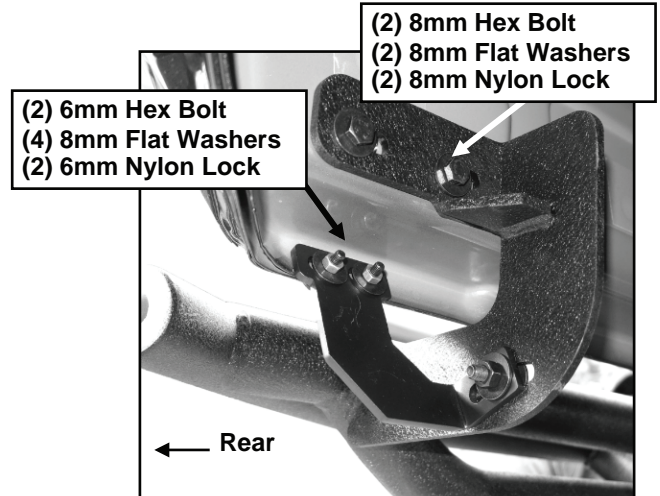

(Fig 14) Driver/Left rear Mounting Bracket assembly

STEP 8

Do periodic inspections to the installation to make sure that all hardware is secure and tight.



IMPORTANT: Some models without holes in in pinch weld will require drilling 1/4" holes through pinch weld to attach driver side front support bracket. Do complete installation of side armors first, level side armor before drilling holes for support bracket.