



STAR ARMOR®

TG-AM2C22128

BEFORE INSTALLATION

READ INSTRUCTIONS CAREFULLY BEFORE STARTING INSTALLATION. REMOVE CONTENTS FROM BOX AND VERIFY ALL PARTS ARE PRESENT. FAILURE TO IDENTIFY DAMAGE BEFORE INSTALLATION COULD LEAD TO A REJECTION OF ANY CLAIM. IF MISSING PARTS OR ANY DAMAGE FOUND, PLEASE TAKE.

TORQUE VALUES

Fastener Size	Class 8.8 Torque (ft-lbs)	Class 10.9 Torque (ft-lbs)
6mm	6-7	6-7
8mm	15-16	22-23
10mm	31-32	44-45
12mm	54-55	78-79
14mm	87-88	125-126

Parts List

- x1 Driver/Left Tyger Armor
- x1 Passenger/Right Tyger Armor
- x1 Passenger/Right Upper Bracket
- x2 8-1.25mm x 35mm Hex Bolts
- x8 8-1.25mm x 25mm Hex Bolts
- x8 8mm Lock Washers
- x4 8mm x 16mm x 1.6mm Flat Washers
- x8 8mm x 24mm x 2mm Flat Washers
- x3 8mm Nylon Lock Nuts
- x3 8mm Clip Nuts
- x4 8mm Nut Plates
- x1 8mm Bolt Plate

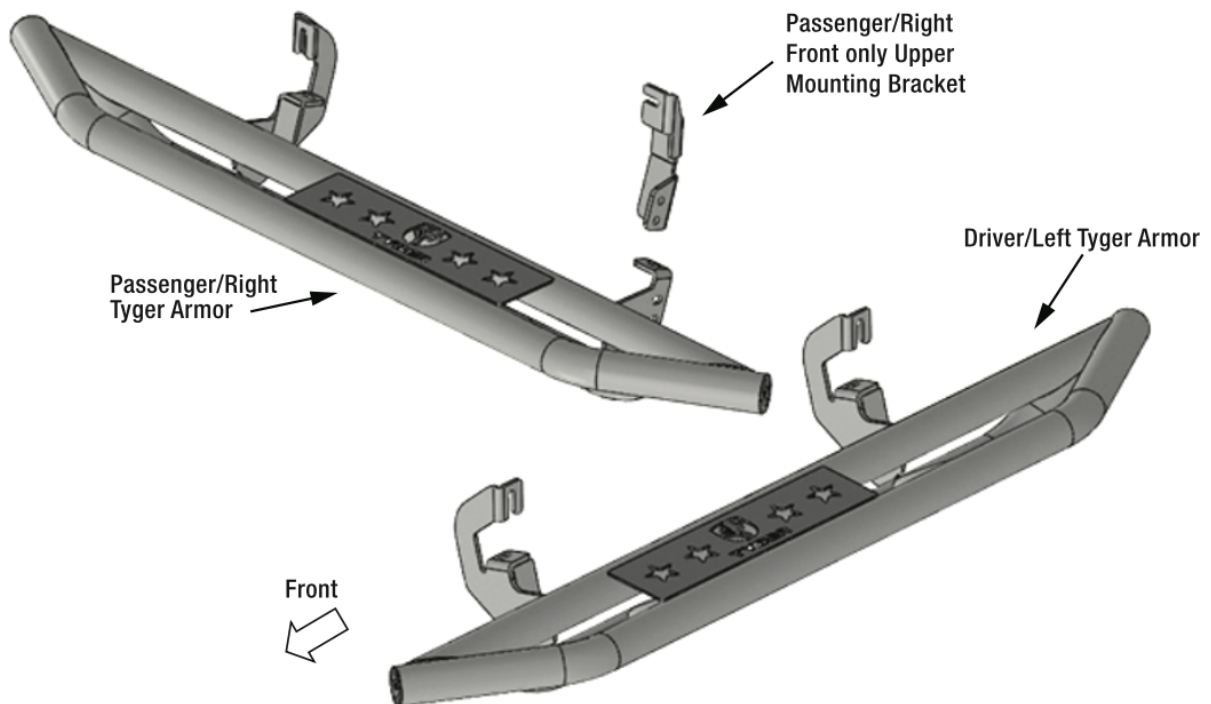



PROCEDURE:

REMOVE CONTENTS FROM BOX. VERIFY ALL PARTS ARE PRESENT. READ INSTRUCTIONS CAREFULLY BEFORE STARTING INSTALLATION. ASSISTANCE IS RECOMMENDED. ON MODELS WITH DEF TANK, SELECT A FLAT, LEVEL AREA FOR INSTALLATION. MAY REQUIRE CUTTING.

STEP 1

Start the installation under the Driver/Left side of the vehicle. Locate the mounting tabs along the bottom edge of the body, (pinch weld). Tyger Armor will bolt to both mounting tabs. Directly above each tab is a top mounting location on the side of the body panel. If necessary, line up the Driver/Left Tyger Armor with the mounting holes in the body panel to help determine correct locations, (Figures 1 & 3).

Driver/Left Side Installation Pictured

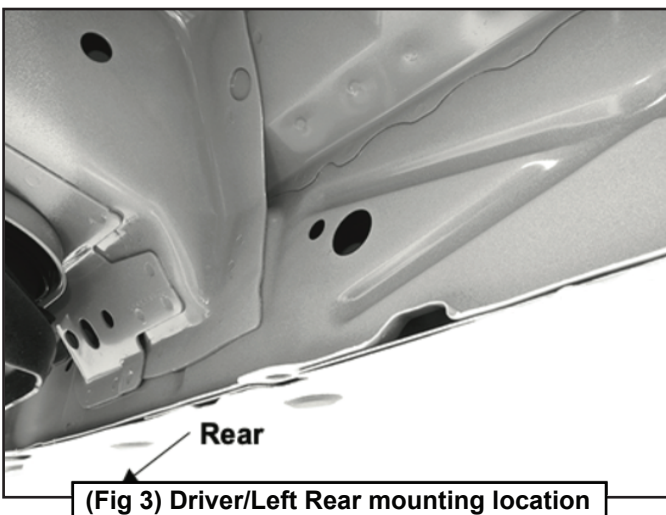
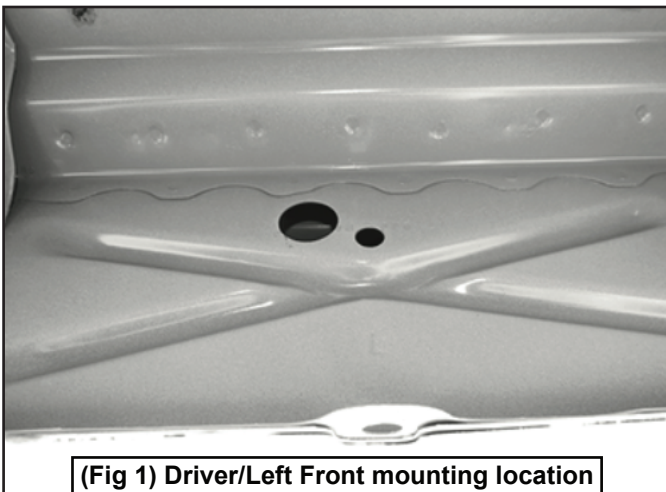

STEP 2

Determine the correct procedure for your model year and each Bracket location.

Bottom mounting location on the edge of the pinch weld.

Flat tab on pinch weld with factory installed weld nut:

Thread hex bolt into weld nut from the backside-down to clear paint from threads, (Figure 2).

Flat tab on pinch weld with hole:

Select (1) 8mm Clip Nut. Slide the Clip Nut over the tab with the nut facing up behind the tab. Repeat this **STEP** for Driver/Left Rear mounting location.

Driver/Left Side Installation Pictured

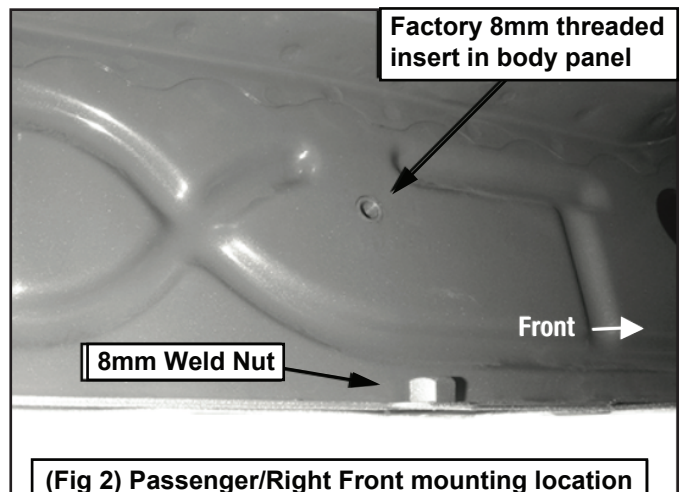

Locate top mounting location on the back side of the body panel

Models with factory installed threaded insert in body panel:

Thread 8mm Hex Bolt into threaded insert to clear paint as required, (Figures 2 & 3).

Large and small holes inside of the body panel:

Remove the rubber plug from the larger hole. Select (1) 8mm Nut Plate. Insert the Nut Plate into the larger hole. Line up the threaded nut with the smaller hole.



STEP 3

Select the Driver/Left Tyger Armor. Attach Tyger Armor to the mounting locations with (4) 8mm x 25mm Hex Bolts, (4) 8mm Lock Washers and (4) 8mm Flat Washers, (Figures 4 & 5). DO NOT tighten hardware.

Driver/Left Side Installation Pictured

- (2) 8mm x 25mm Hex Bolts
- (2) 8mm Lock Washers
- (2) 8mm Flat Washers

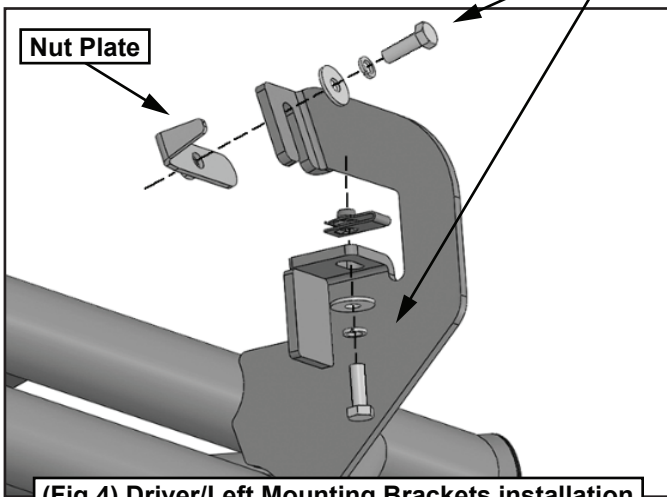

(Fig 4) Driver/Left Mounting Brackets installation

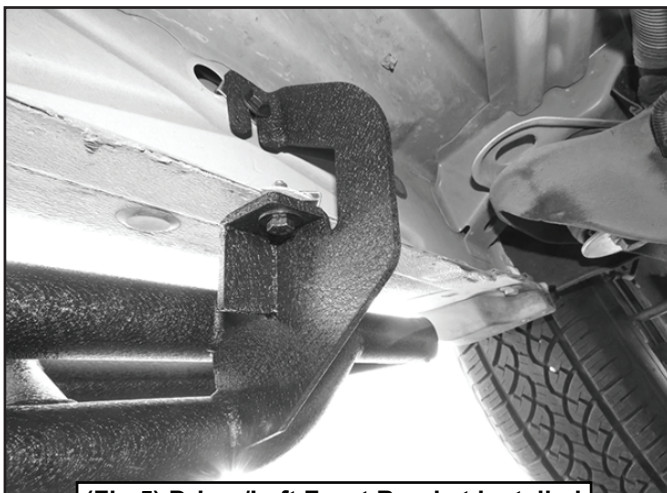

(Fig 5) Driver/Left Front Bracket installed

STEP 4

Level and adjust the Tyger Armor and fully tighten all hardware.

STEP 5

Move to the passenger side of the vehicle. On the Passenger/Right, determine if the vehicle is equipped with a plastic diesel exhaust fluid (DEF) tank, (Figures 6 & 7).

Driver/Left Side Installation Pictured

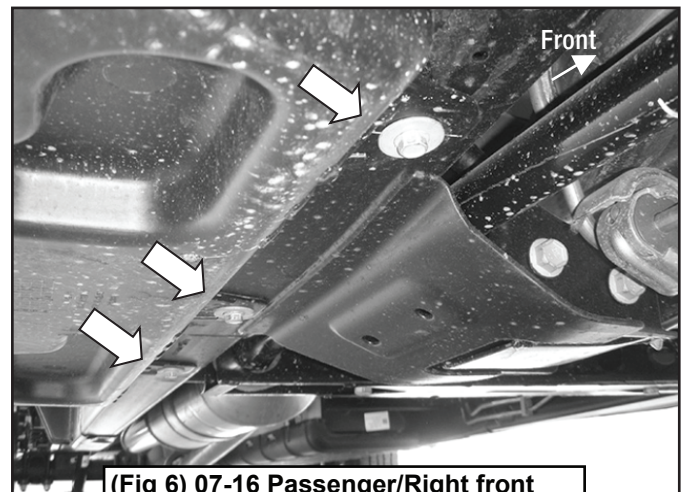

(Fig 6) 07-16 Passenger/Right front pictured with DEF tank cover. Remove (3) hex bolts to remove cover

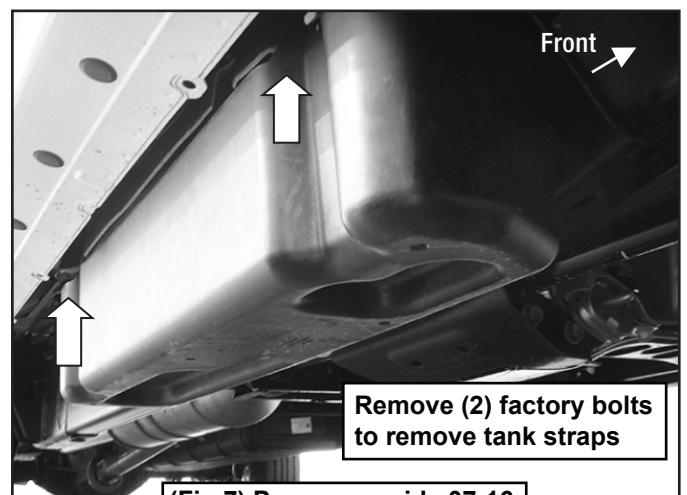

Remove (2) factory bolts to remove tank straps

(Fig 7) Passenger side 07-16 DEF tank and cover



STEP 6

Determine the model/year:

Models without DEF tank, skip to STEP 7.

Models with DEF tank: The tank sits close to the side of the body. With specialized tools, the passenger front upper and lower Bracket can be installed but room is limited.

For 2007—2016 models:

It may be easier to drop the tank down to access the inner side of the body panel for upper bracket installation. Tank will not need to be removed, only dropped down for access to mounting location.

IMPORTANT: If tank is full, it will be very heavy and assistance is highly recommended to avoid injury or damage to the vehicle or the tank. It is recommended that installation is performed when the DEF tank is low on fluid before dropping the tank.

a. For models with plastic lower tray under the tank, remove the (3) hex bolts attaching the tray to the frame, (Figure 6), and remove tray.

b. Release the tank filler hose. Release the plug for the sending unit on the top of the tank.

c. Support the tank with a floor jack. Place a smooth flat surface, (wooden block for example), between the floor jack and the tank to avoid damaging the plastic tank. Do not push up on the tank; only support the weight of the tank with the jack.

d. Remove the (2) bolts securing the tank straps to the vehicle, (Figure 7). Tilt the straps to release from the brackets. Slowly lower the tank until the top of the tank is almost visible. Use blocks or stands to support the tank while installing the front Upper and Lower Brackets.

e. Proceed to **STEP 7**.

For 2017—2018 models:

Remove the (4) hex bolts attaching the plastic cover to DEF tank, (Figures 8A & 8B) and remove plastic cover.

IMPORTANT: DO NOT remove tank.

Driver/Left Side Installation Pictured

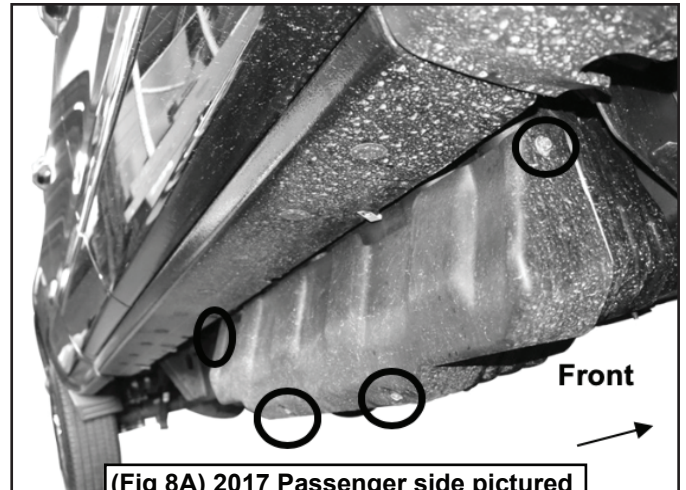

(Fig 8A) 2017 Passenger side pictured with DEF plastic tank cover. Remove (4) hex bolts to remove plastic cover

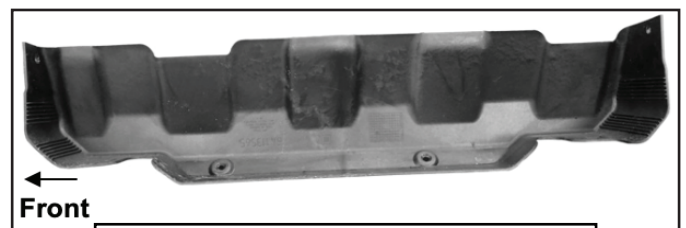

(Fig 8B) 2017 Passenger side DEF cover

STEP 7

Locate the front tab on the edge of the pinch weld on the Passenger/Right side.



STEP 8

Select the Passenger/Right Upper Mounting Bracket, (Figure 9).

Driver/Left Side Installation Pictured

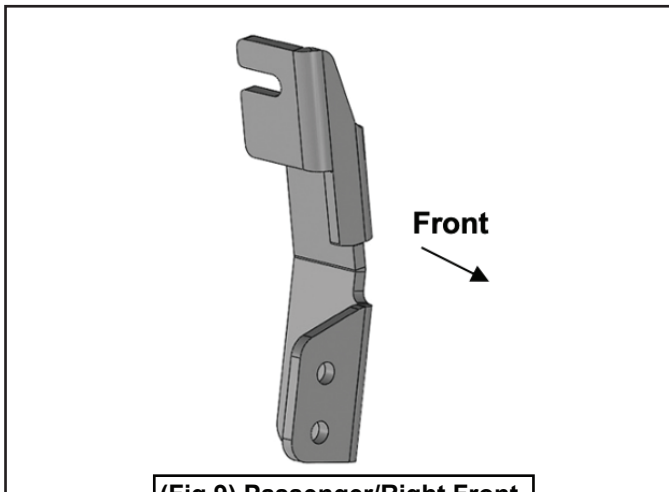

(Fig 9) Passenger/Right Front Upper Bracket (all models)

a. For models with threaded upper mounting holes. Attach the upper mounting bracket to the rocker panel with (1) 8mm x 25mm Hex Bolt, (1) 8mm Lock Washer and (1) 8mm x 24mm Flat Washer, (Figure 10).

8mm x 25mm Hex Bolts
8mm Lock Washers
8mm Flat Washers

8mm Nut Plate (not required with threaded holes in rocker panel)

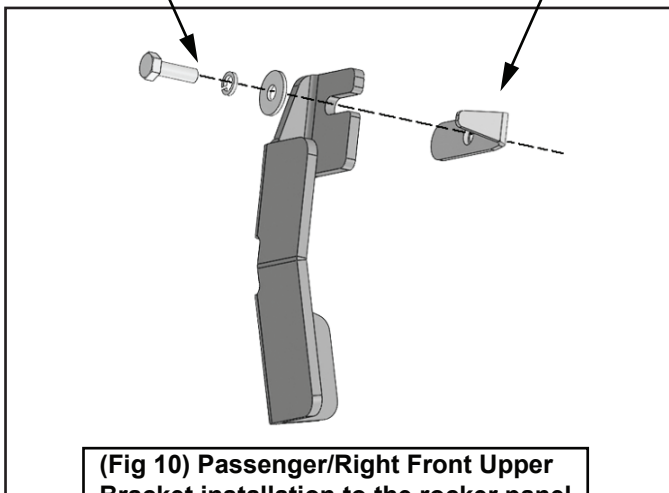

(Fig 10) Passenger/Right Front Upper Bracket installation to the rocker panel

b. For models with Large and small holes in the rocker panel. Attach the upper mounting bracket to the rocker panel with (1) 8mm x 25mm Hex Bolt, (1) 8mm Lock Washer, (1) 8mm x 24mm Flat Washer and (1) 8mm Nut Plate, (Figure 10).

Models with a weld-nut on the Pinch Weld:

a. Select the Passenger/Right Tyger Armor. Attach the front mounting bracket to the pinch weld with (1) 8mm x 35mm Hex Bolt, (1) 8mm Lock Washer and (1) 8mm x 24mm Flat Washer, (Figure 12).

b. Repeat **STEPS 2—3** to attach the rear mounting flange on the Tyger Armor to the Passenger/Right rear mounting location.

Models with flat tab and hole in the Pinch Weld:

a. Select the Passenger/Right Tyger Armor. Attach the front Tyger Armor to the pinch weld with (1) 8mm Bolt Plate, (1) 8mm x 24mm Flat Washer and (1) 8mm Nylon Lock Nut, (Figures 11 & 12).

b. Repeat **STEPS 2—3** to attach the rear mounting flange on the Tyger Armor to the Passenger/Right rear mounting location.

Driver/Left Side Installation Pictured



(Fig 11) 8mm x 35mm Bolt Plate

Models with flat tab on panel:
Use 8mm Bolt Plate

Models with weld nut on panel use:
8mm Hex Bolt
8mm Lock Washer
8mm x 24mm Flat washer

Fig 12

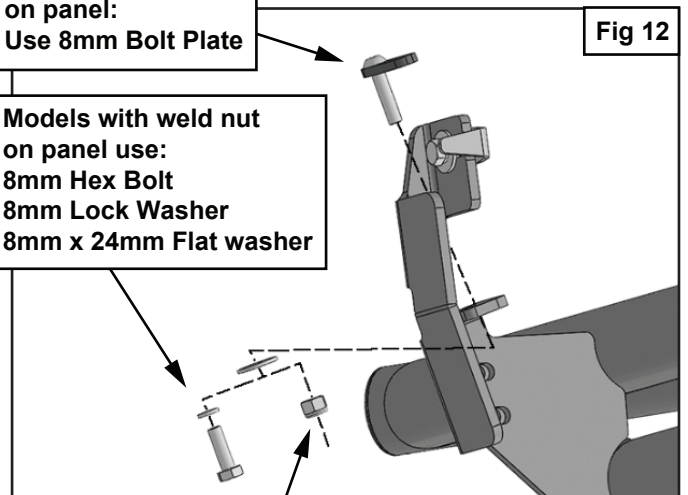

8mm x 24mm Flat Washer
8mm Nylon Lock Nut



TYGER®

STEP 9

Attach the Upper Mounting Bracket to the Tyger Armor front mounting flange with (2) 8mm x 35mm Hex Bolts, (4) 8mm x 26mm Flat Washers and (2) 8mm Nylon Lock Nuts, (Figure 13).

Driver/Left Side Installation Pictured

(2) 8mmx 35mm Hex Bolts
(4) 8mm Lock Washers
(2) 8mm Nut Plates

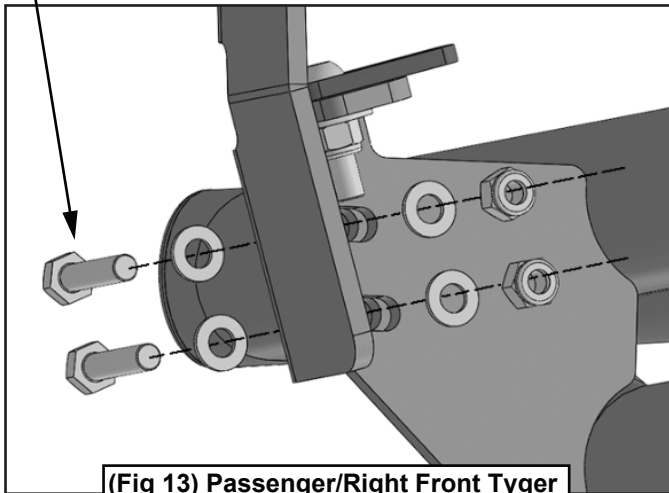

(Fig 13) Passenger/Right Front Tyger Armor to Upper Bracket installation

STEP 10

2017 on 2500/3500 DEF tank models: Locate the rear mounting location along the bottom edge of the body, (pinch weld). Hold the DEF cover in place and mark the rear bracket location onto the cover, (Figure 14). Use a sharp knife or hacksaw blade to carefully cut a slot in the plastic cover to clear the 2nd Bracket, (Figure 15). Remove as little plastic as possible.

Driver/Left Side Installation Pictured

mark pictured is approximately 70mm x 10mm

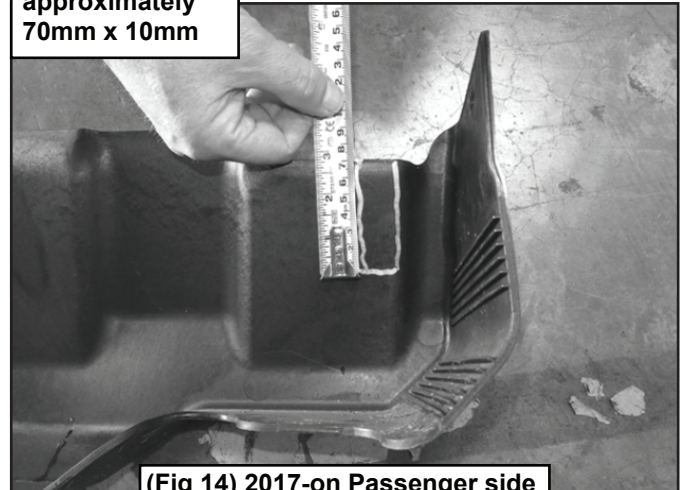

(Fig 14) 2017-on Passenger side DEF cover marked for trimming

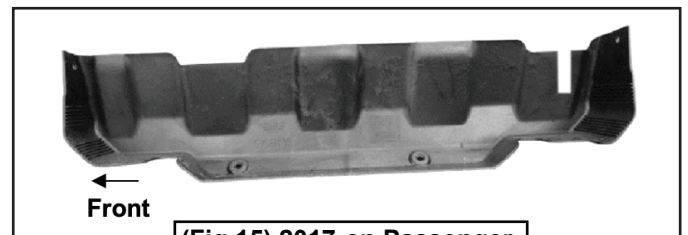

(Fig 15) 2017-on Passenger DEF cut for example only

STEP 11

Level and adjust the Tyger Armor and fully tighten all hardware.

STEP 12

Once fully installed and all hardware fully tightened, reinstall the DEF tank and cover, if equipped, as described in **STEPS 5 & 6**.

STEP 13

Do periodic inspections to the installation to make sure that all hardware is secure and tight.