



TYGER[®]

STAR ARMOR[™]

TG-AM2C20248

NOTE: Assistance is recommended.

BEFORE INSTALLATION

READ INSTRUCTIONS CAREFULLY BEFORE STARTING INSTALLATION. REMOVE CONTENTS FROM BOX AND VERIFY ALL PARTS ARE PRESENT. FAILURE TO IDENTIFY DAMAGE BEFORE INSTALLATION COULD LEAD TO A REJECTION OF ANY CLAIM. IF MISSING PARTS OR ANY DAMAGE FOUND, PLEASE TAKE A PICTURE FOR THE CLAIM PURPOSE.

Torque Value

Fastener Size	Class 8.8 Tightening Torque (ft-lbs)	Class 10.9 Tightening Torque (ft-lbs)
6mm	6-7	6-7
8mm	15-16	22-23
10mm	31-32	44-45
12mm	54-55	78-79
14mm	87-88	125-126

Parts List

- x1 Driver/left side TYGER Armor
- x1 Passenger/right side TYGER Armor
- x16 8mm x 30mm Hex Bolts
- x16 8mm Lock Washers
- x16 8mm x 24mm x 2mm Flat Washers

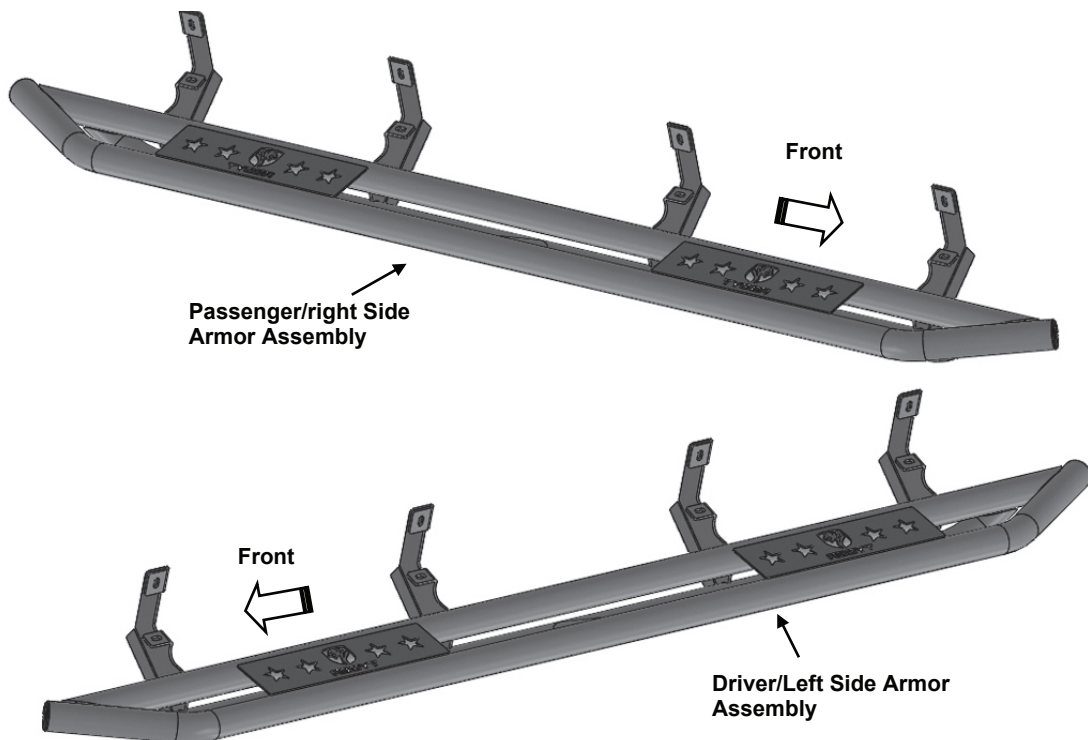



STEP 1

Start the installation under the passenger side of the vehicle. Locate the 6 plugs along the bottom edge of the body. Side Armor will bolt to the 1st, 3rd, 4th and 5th threaded mounting holes, (Figs 1-6).

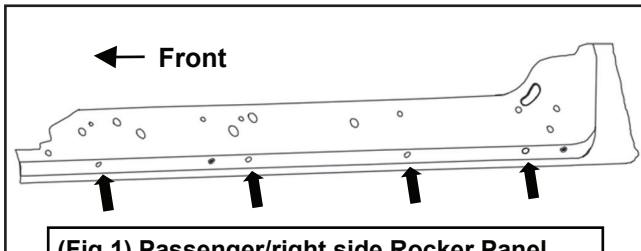

(Fig 1) Passenger/right side Rocker Panel mounting locations illustrated (arrows)
NOTE: Hold Bracket up to body panel to help determine the correct mounting locations.

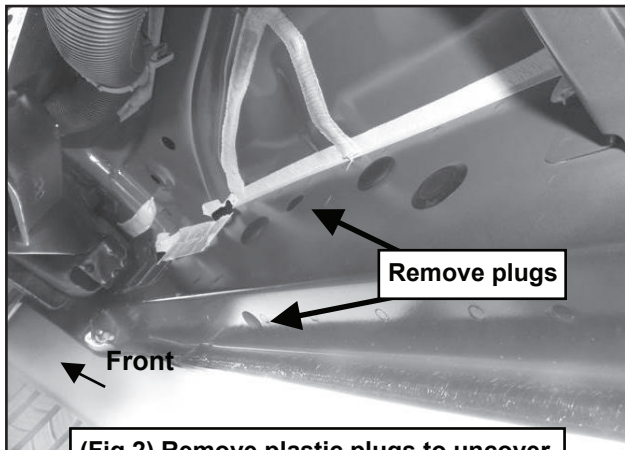

(Fig 2) Remove plastic plugs to uncover threaded inserts

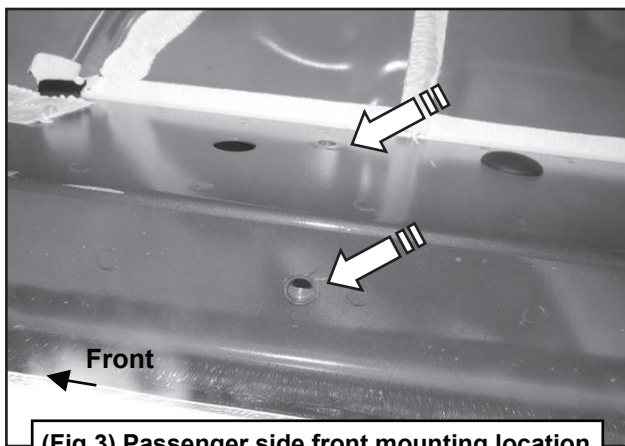

(Fig 3) Passenger side front mounting location

Remove the plastic plugs from each mounting location. Directly above each threaded insert is a top mounting location on the side of the body panel. Hold Side Armor up in place to help determine the mounting holes to use along the body.

NOTE: Thread an 8mm Hex Bolt into the threaded inserts to clear paint as required.

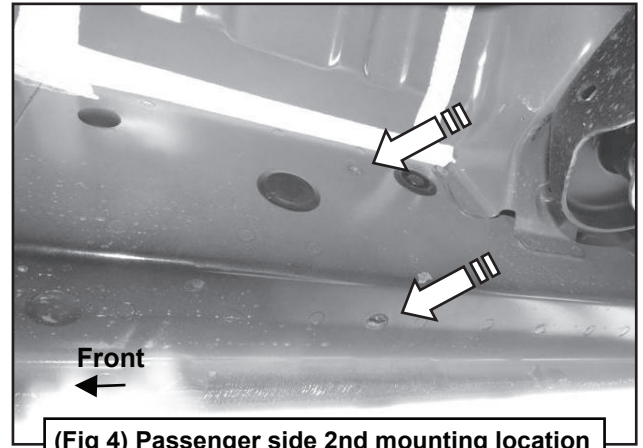

(Fig 4) Passenger side 2nd mounting location

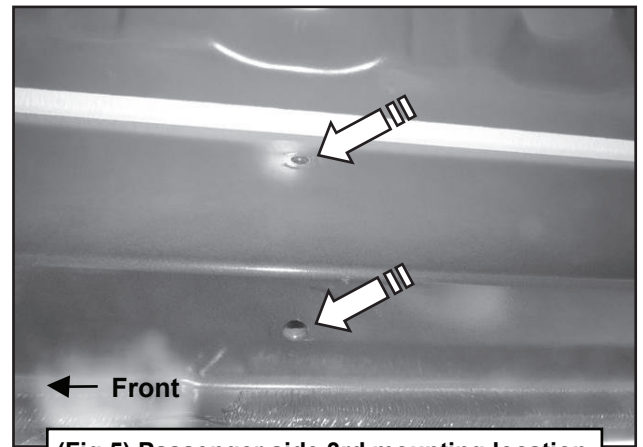

(Fig 5) Passenger side 3rd mounting location

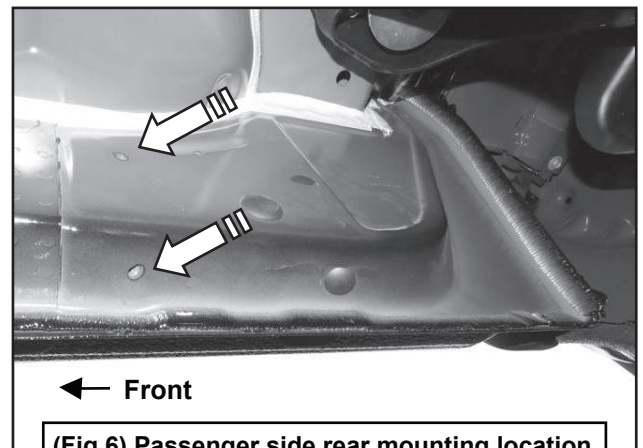

(Fig 6) Passenger side rear mounting location



STEP 2

Carefully unwrap and select the Passenger/right Side Armor.

NOTE: When installed correctly, the tabs on the welded brackets will face towards the front of the vehicle. Use the illustration above to help identify the correct Side Armor.

STEP 3

With assistance, attach the welded Brackets on the Side Armor to the body panel using (8) 8mm Hex Bolts, (8) 8mm Lock Washers and (8) 8mm Flat Washers, (Figs 7-9).

NOTE: When installed properly, the tabs on the welded brackets of the Side Armor will face towards the front.

(2) 8mm Hex Bolts
(2) 8mm Lock Washers
(2) 8mm Flat Washers

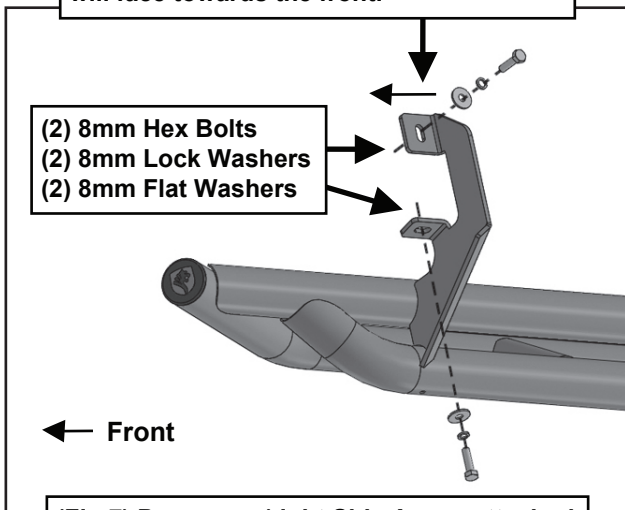

(Fig 7) Passenger/right Side Armor attached to front of body panel illustrated

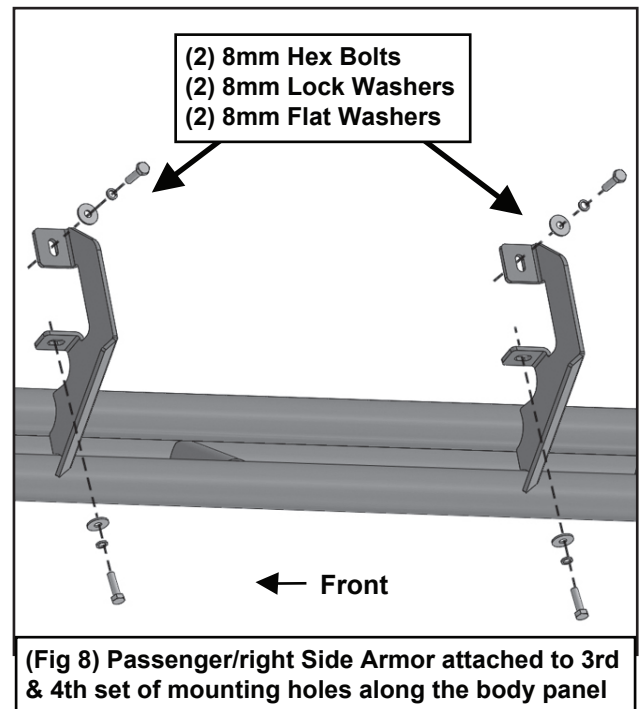

(Fig 8) Passenger/right Side Armor attached to 3rd & 4th set of mounting holes along the body panel

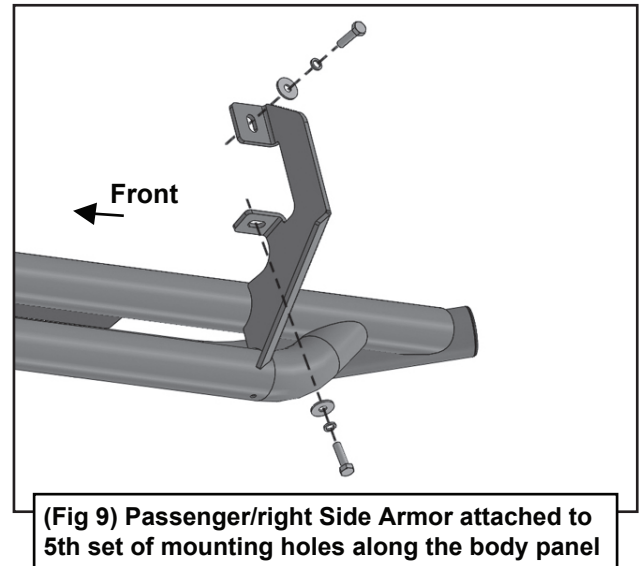

(Fig 9) Passenger/right Side Armor attached to 5th set of mounting holes along the body panel



TYGER[®]

STEP 4

Level and adjust the Side Armor properly and tighten all hardware.

STEP 5

Repeat Steps 1-4 for driver/left Side Armor assembly installation.

STEP 6

Do periodic inspections to the installation to make sure that all hardware is secure and tight.

