

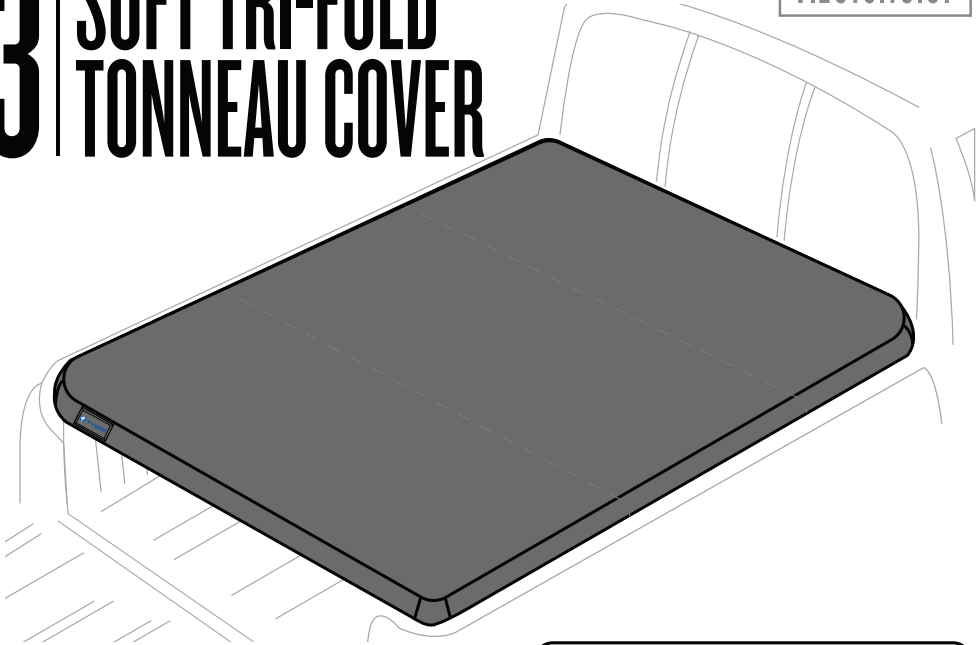

# TYGER®

# T3 | SOFT TRI-FOLD TONNEAU COVER

V.2019.10.07



## ATTENTION!

READ INSTRUCTIONS CAREFULLY BEFORE STARTING INSTALLATION. REMOVE CONTENTS FROM BOX AND VERIFY ALL PARTS ARE PRESENT. FAILURE TO IDENTIFY DAMAGE BEFORE INSTALLATION COULD LEAD TO REJECTION OF ANY CLAIM.

## ITEMS LIST (ONLY MARKED ITEMS ARE INCLUDED)

**x1** Bed Cover

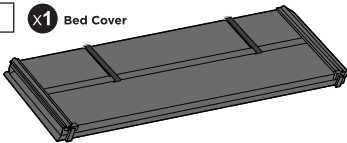

**x1** SP-BC0003 Front Seal Strip 67" x 1" x 0,4"

**x1** SP-BC0004 Front Seal Strip 67" x 1,4" x 0,16"

**x1** SP-BC0005 Rear Seal Strip 79" x 1,2" x 0,24"



**x4** SP-BC3002 Clamp Pad



**x1** SP-BC3006 Tool



**x6** SP-BC3003B For Toyota



**x6** SP-BC3004 For Nissan Titan



**x6** SP-BC3005 For Nissan Frontier

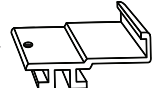

**x6** SP-BC3060 For Jeep Gladiator

- 1**
- Clean truck bed thoroughly before installation.
  - Stick the supplied front seal strip on the front bed rail by aligning with the outer edge.
  - Place the assembled cover on the bulkhead against the cab and release the safety buckles.

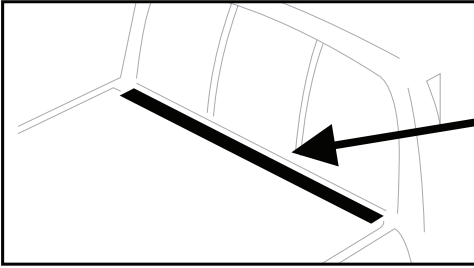

You might need:



**Seal Strip**

(Only apply to some models)



## ATTENTION!

- IF THE TRUCK'S FRONT BED RAIL IS LOWER THAN THE SIDES, USE THE PROVIDED WEATHER SEAL STRIPS. GAPS ON THE FRONT BED AND TAILGATE WILL CAUSE NOISE AND FLAPPING ISSUES WHILE THE VEHICLE IS IN MOTION!

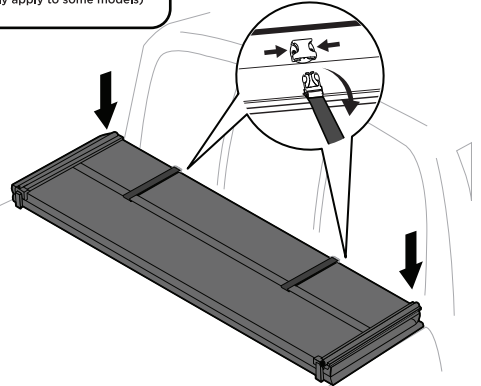

(Optional)



**SP-BC0005**

**Note:**

At the bottom of the tailgate, stick the supplied weather strip vertically on the side to seal out any weather elements.

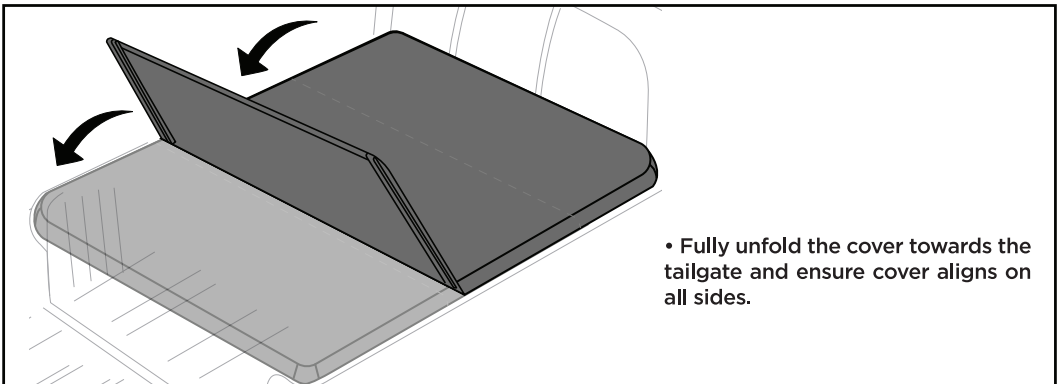

- Fully unfold the cover towards the tailgate and ensure cover aligns on all sides.

**2**

- Carefully refold the cover without moving its position on the truck bed

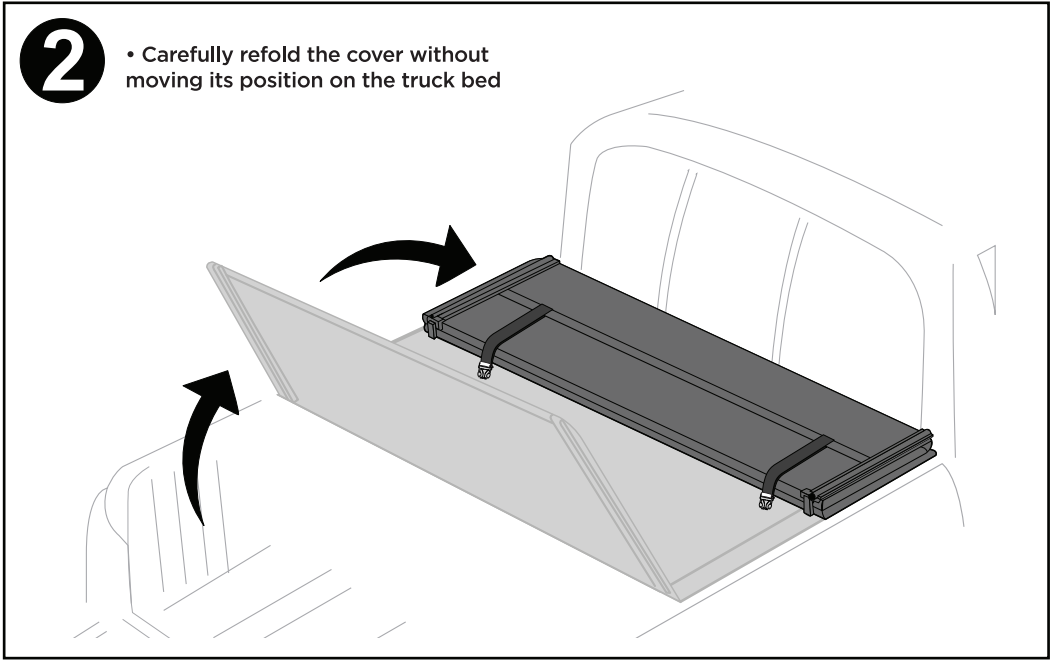

**3**

**CLAMPS**

- These clamps are already attached to the assembled cover.

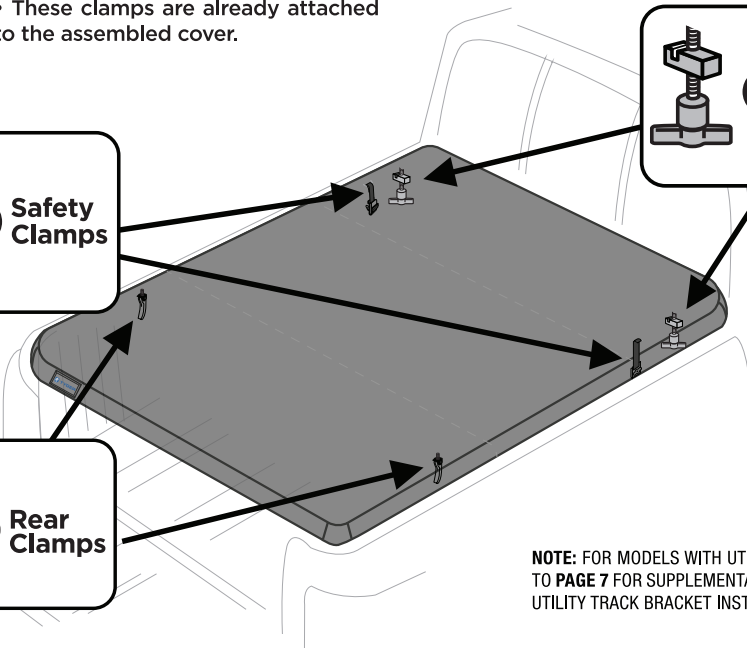
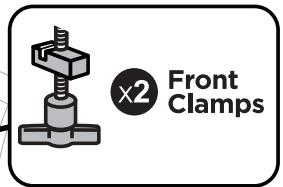

**NOTE:** FOR MODELS WITH UTILITY TRACK, REFER TO **PAGE 7** FOR SUPPLEMENTAL INSTRUCTION ON UTILITY TRACK BRACKET INSTALLATION.

## 4 FRONT CLAMPS USAGE

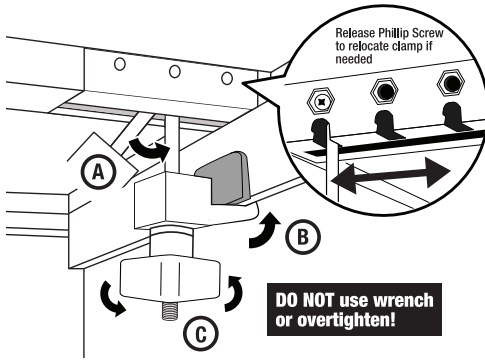

- A** Pull down front clamps into vertical position.
- B** Hook jaw portion of the clamp under the metal bed rail lip. Clamp pad can be inserted at the contact point to protect paint.
- C** Turn the knob until side Q-seal of the cover is compressed and clamp is snug

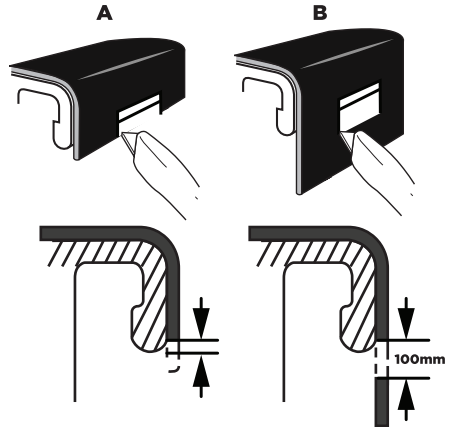
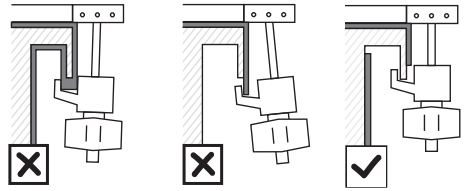

### ATTENTION!

FOR TYPE A OR B OVER-THE-RAIL BEDLINER SHOWN ABOVE, A SMALL HOLE LARGE ENOUGH TO FIT THE CLAMP WILL NEED TO BE CUT SO THE CLAMP CAN BE FASTENED SECURELY TO THE METAL PART OF THE TRUCK BED LIP!

## 5 SAFETY CLAMPS USAGE

- Turn the knob counterclockwise to loosen the safety clamp with the strap, attach clamp to the metal bed rail lip on both side, then tighten.



### ATTENTION!

- SAFETY CLAMPS MUST BE SECURED PROPERLY TO THE **METAL PART** WHEN VEHICLE IN MOTION, OTHERWISE THE WARRANTY WILL BE VOIDED.

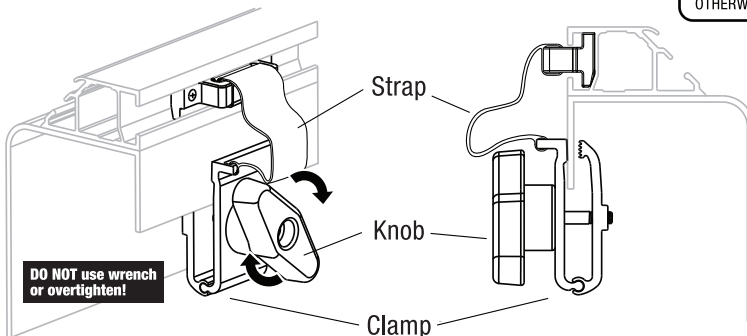

- 6** • Unfold the cover completely towards the tailgate.

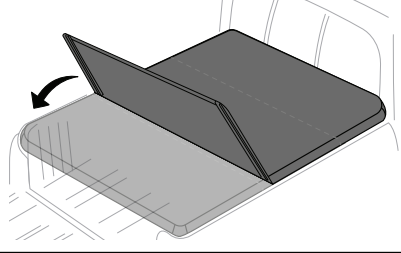

## 7 REAR CLAMPS USAGE

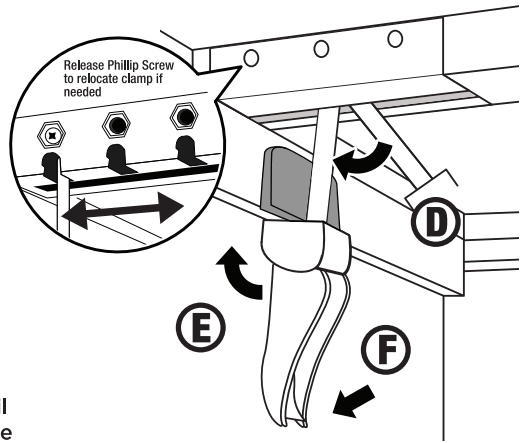

- D** Pull down rear clamps.
- E** Hook clamps under the metal bed rail lips. Clamp pad can be inserted at the contact point to protect paint
- F** Push clamp handle down to vertical position to secure the rear latch; make sure side Q-seal of the cover is compressed and clamps are snug.



### ATTENTION!

- ALL CLAMPS MUST MAKE SOLID CONTACT WITH THE **METAL BED RAIL LIP** FOR THE COVER TO BE SECURE.

## 8 FINISH THE INSTALLATION

- After rear clamps have been latched securely, close/lock tailgate and cover cannot be opened from the outside.

# COMPLETED!!!

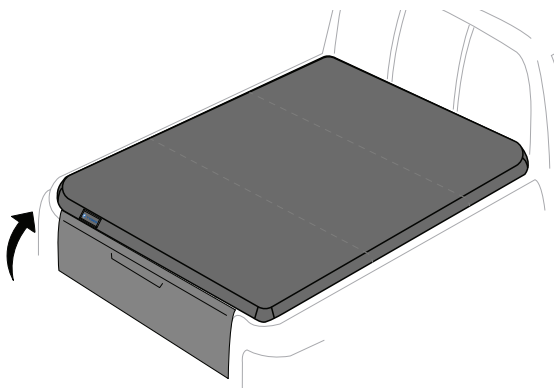

DO NOT OVERLOAD CARGO



DO NOT PLACE SHARP OBJECTS ON TOP



REMOVE SNOW BEFORE FOLDING COVER



SECURE ALL CLAMPS BEFORE DRIVING



USE SEAL STRIPS FOR EXPOSED GAPS TO AVOID LEAKING



DO NOT CLEAN WITH ABRASIVE CHEMICALS RECOMMEND TO USE TYGER CLEAN & PROTECTANT SPRAY

**NOTE:** COVER MAY NOT COMPLETELY COVER TO THE OUTSIDE EDGE OF THE BED RAILS DUE TO SLIGHT DIFFERENCE IN TRUCK BED SHAPE FOR DIFFERENT YEAR MODELS.

# 9 FOLDING UP THE COVER

• Open tailgate and release rear latches. Fold up the cover once; secure rear latch on both sides into the groove with the clamp jaw portion facing down as shown in Fig.1. Any other incorrect methods shown in Fig.2 - 4 will cause damage to the vinyl and will void warranty.

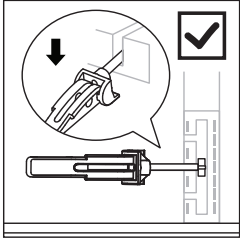

Fig. 1

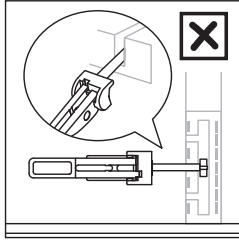

Fig. 2

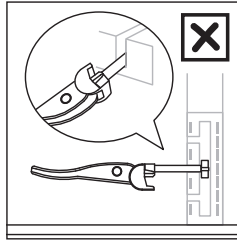

Fig. 3

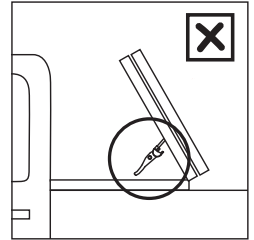
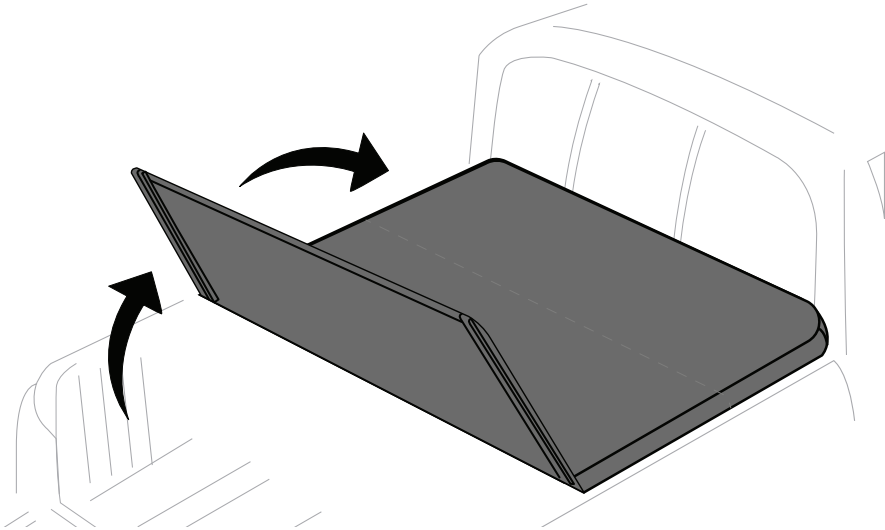
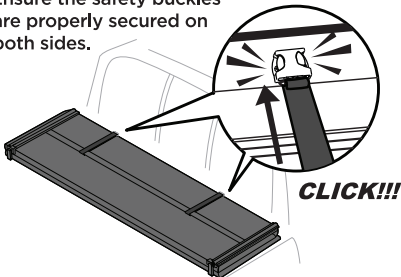

Fig. 4



• Ensure the safety buckles are properly secured on both sides.



## ATTENTION!

• DO NOT RELEASE THE FRONT CLAMPS AND SAFETY CLAMPS WHEN YOU UNFOLD THE COVER, AND MAKE SURE THEY ARE ALL SECURED!

# SPECIAL INSTRUCTIONS FOR ALTERNATIVE BRACKETS

SUPPLEMENT TO INSTALLATION INSTRUCTIONS (Only for models with utility track)

## For NISSAN FRONTIER

You will need:



SP-BC3005

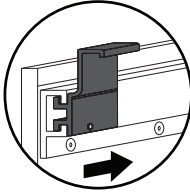

**a** Slide aluminum blocks into track

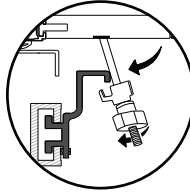

**b** Attach **Front Clamps** on to aluminum block

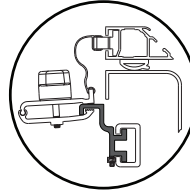

**c** Attach **Safety Clamps** on to aluminum block

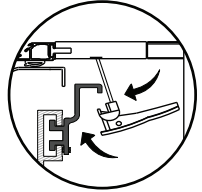

**d** Attach **Rear Clamps** on to aluminum block

## For NISSAN TITAN

You will need:



SP-BC3004

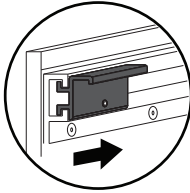

**a** Slide aluminum blocks into track

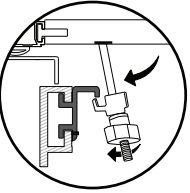

**b** Attach **Front Clamps** on to aluminum block

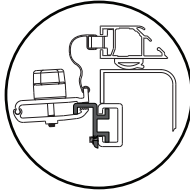

**c** Attach **Safety Clamps** on to aluminum block

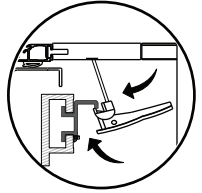

**d** Attach **Rear Clamps** on to aluminum block

## For TOYOTA

You will need:



SP-BC3003B

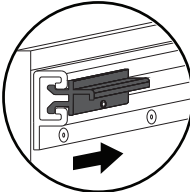

**a** Slide aluminum blocks into track

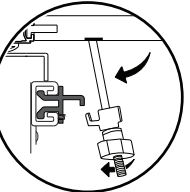

**b** Attach **Front Clamps** on to aluminum block

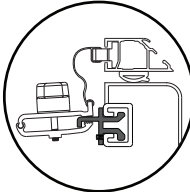

**c** Attach **Safety Clamps** on to aluminum block

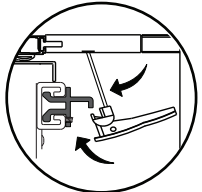

**d** Attach **Rear Clamps** on to aluminum block

## For JEEP GLADIATOR

You will need:



SP-BC3060

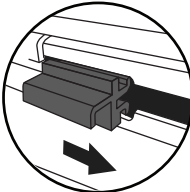

**a** Slide aluminum blocks into track

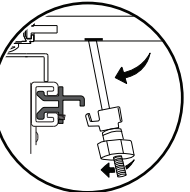

**b** Attach **Front Clamps** on to aluminum block

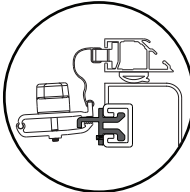

**c** Attach **Safety Clamps** on to aluminum block

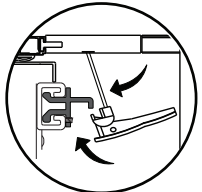

**d** Attach **Rear Clamps** on to aluminum block

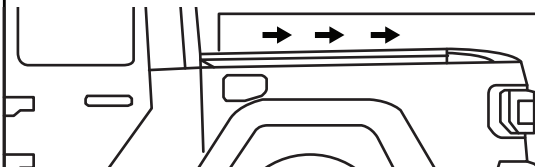

**JEEP GLADIATOR MODEL  
SLIDES FROM THE FRONT**