

# TURBOXS

## Installation Instructions *BOV-H-RFL*



### Package Contents

- Blow Off Valve Type H-RFL
- Aluminium Weldable Adapter
- Mild Steel Weldable Adapter
- Six Adjustment Washers
- Hex Key

**It is recommended that this installation be carried out by a qualified mechanic**

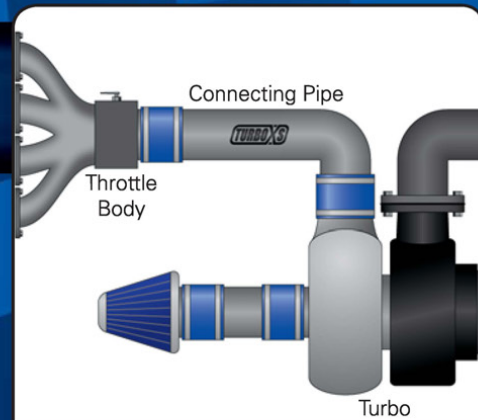

**1**

Locate the connecting pipe that runs to the throttle body from the turbo, or from the (intercooler if one is fitted).



**2**

Mark the pipe for cutting (ensuring adequate hood and engine clearance) and remove it from the vehicle.

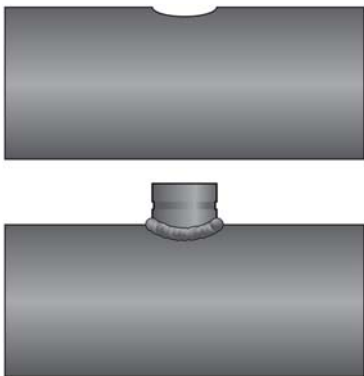
**3**

Cut & clean a 1.25" (32mm) hole in the connecting pipe. Insert the longer end of the appropriate adapter and weld.

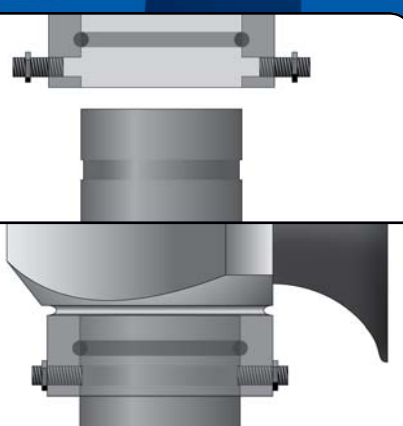
**1****2****4**

Clean the pipe and reinstall in vehicle. Attach BOV to adapter and tighten grub screws. Tighten locking nuts to secure.

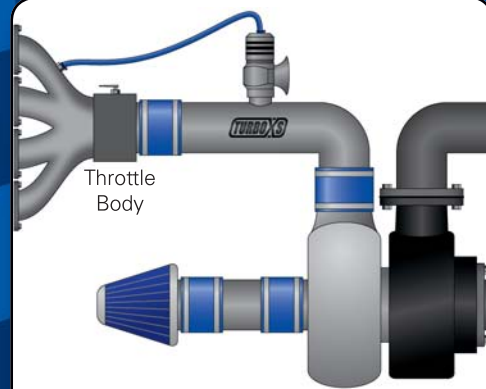

Throttle  
Body

**5**

Attach top nipple to a vacuum source on the engine side of the throttle body with 4mm ID hose. Secure hose ends.

### Adjustment Guide *(Note: adjustment is not necessary if engine idles smoothly)*

**1**

Remove the spring-loaded cap with caution. Remove the spring but do not remove any other components.

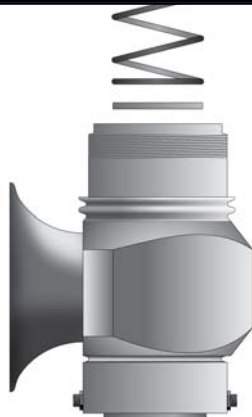
**2**

Insert one adjustment washer beneath the spring and replace cap.

**3**

If the engine does not idle smoothly, add an additional washer and re-test. Repeat adjustment until idle is smooth.