

Product Name: **Gen V ALV Valve**
 Product Description: Gen V Antilag Valve
 Product Number: TS-055X-14XX
 Document Version: V1.00 Rev A



IMPORTANT NOTES ON YOUR ANTILAG VALVE

- Turbosmart accepts no responsibility whatsoever for incorrect installation of this product which is potentially hazardous and can cause serious engine damage or personal injury.
- Antilag produces excessive heat in the exhaust system and may shorten the life of your exhaust manifold and turbo
- Consult your local specialist before setting your setting your antilag valve, setting antilag levels beyond your engines capability may result in engine or turbo damage.
- Use only high-quality fittings ensuring maximum sealing reliability. Optional Turbosmart fitting kit available.
- Turbosmart's ALV valve is recommended for race applications only.

RECOMMENDATIONS

- **Allow for adequate cool airflow around the top diaphragm housing**
- **DO NOT Mount the ALV so that the top diaphragm housing is less than 100mm from a heat source**
- **DO NOT wrap the body of the ALV with exhaust wrap**
- **Fitting your Gen V ALV may require fabrication or modification to your exhaust manifold. Turbosmart recommends that your ALV is fitted by an appropriately qualified technician.**
- Fitting the ALV to your turbocharger system introduces fresh air into the exhaust system post engine and therefore air fuel ratios will show as lean.
- Turbosmart recommends that antilag settings are set using a dynamometer and not on public roads.
- Turbosmart recommends that a boost gauge be permanently fitted to the vehicle.

KIT CONTENTS

Please check that the following items have been provided in your Gen V ALV kit.

| Part | Description | Use |
|------|----------------------|--|
| 1 | Turbosmart Gen V ALV | Main unit |
| 2 | Valve seat | Valve seat |
| 3 | Inlet V-band clamp | Inlet V-band clamp |
| 4 | Inlet hose adapter | Inlet Hose adapter |
| 5 | Outlet V-band clamp | Outlet V-band clamp |
| 6 | Inlet weld flange | Inlet V-band weld flange |
| 7 | Collar tool | Adjusting actuator and changing springs |
| 8 | Fitting kit | 2x 1/8" NPT nipple, 2x 1/8" NPT blanking plugs ** (1x pre-installed) ** |
| 9 | Inlet O-ring | O-Ring seal for inlet |
| 10 | Turbosmart sticker | Turbosmart sticker |

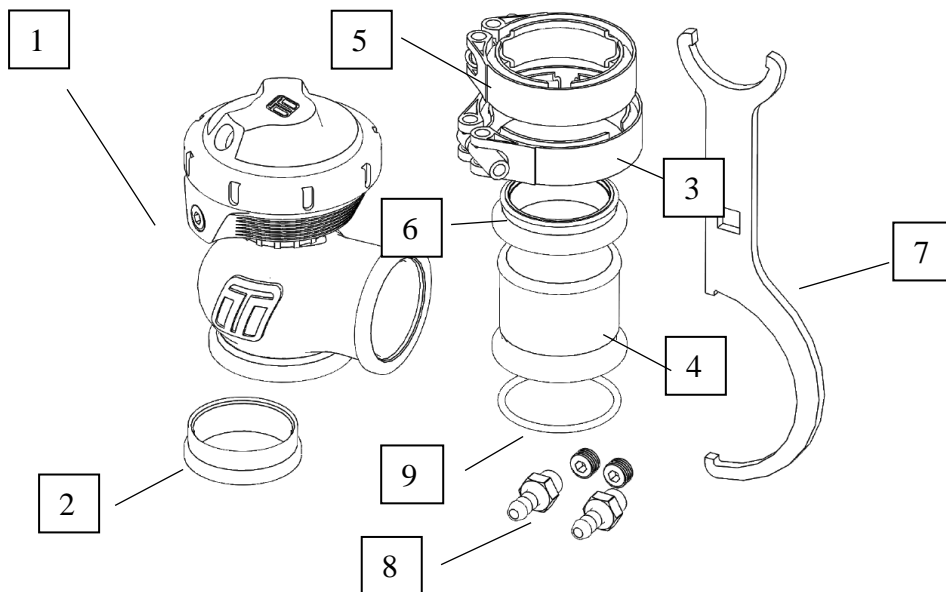

Figure 1 - Kit Contents

Important Note: The outlet weld flange is sold separately, purchase accordingly, see page 3.

CONTENTS

| | |
|---|-------------------------------------|
| KIT CONTENTS | 1 |
| TOOLS REQUIRED | 2 |
| SUGGESTED SEALANTS | 2 |
| GEN V ALV OVERVIEW | 3 |
| FITTING YOUR GEN V ALV | 3 |
| Control Hookup | 5 |
| Vacuum Pump..... | 6 |
| Compressor..... | 7 |
| Tuning Strategies | 8 |
| HOW TO CHANGE YOUR GEN V ALV SPRING | Error! Bookmark not defined. |
| HOW TO CHANGE YOUR GEN V ALV DIAPHRAGM..... | 8 |
| ----- | 11 |
| HOW TO INSTALL A SENSOR CAP TO YOUR GEN V ALV | 11 |
| TROUBLE SHOOTING | 14 |

TOOLS REQUIRED

- 3/8" square drive deep socket
- Square drive ratchet wrench
- Torque wrench (3/8" drive)
- Non-marking spanners to tighten fittings
- 3/16" hex key
- Supplied collar tool
- 14mm 12-point (double hex) socket
- Flat blade screwdriver
- Small hammer

SUGGESTED SEALANTS

- Loctite 243 Thread locker
- Loctite 567 Thread Sealant
- Penetrating oil

GEN V ALV OVERVIEW

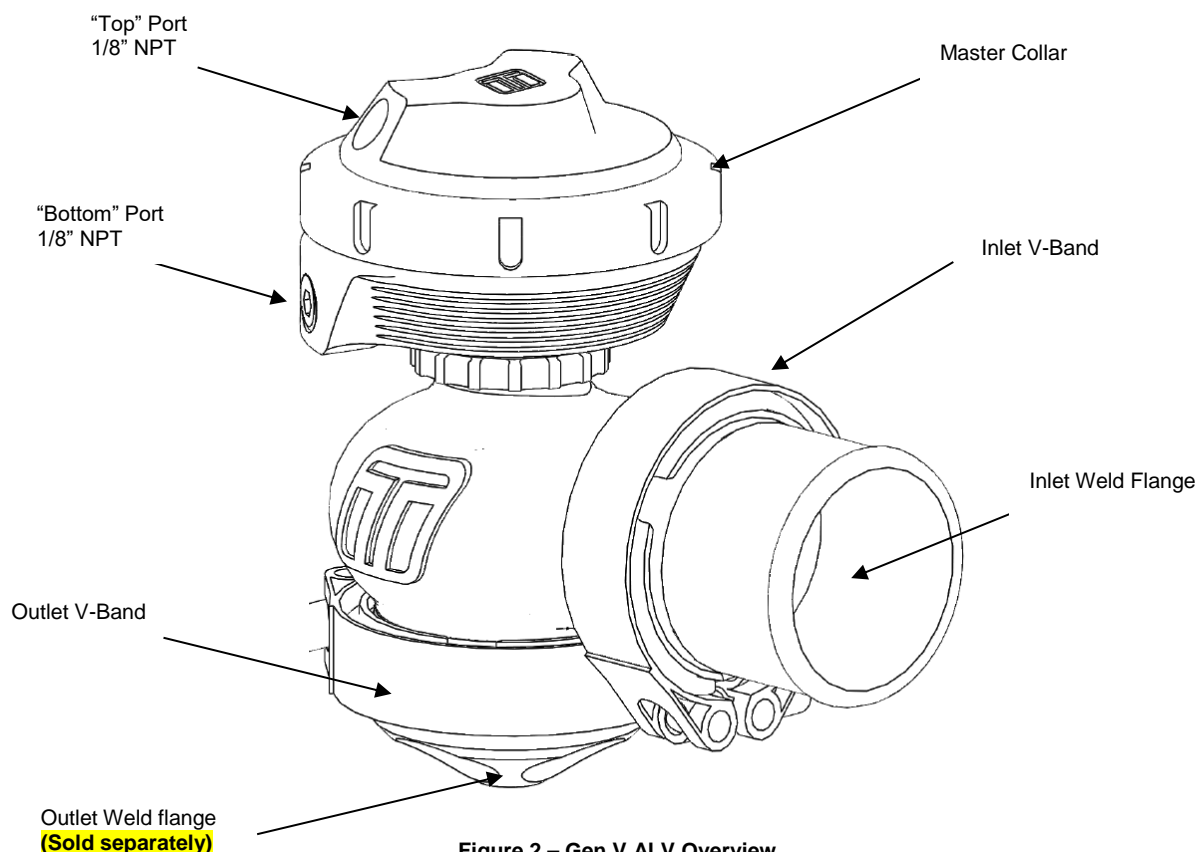

GEN V ALV Accessories

| | |
|---------------------|--|
| TS-0550-3098 | ALS 4-1 Weld flange (for 4 cylinder/V8/4 outlet pipes) |
| TS-0550-3099 | ALS 3-1 Weld flange (for 3 cylinder/V6/3 outlet pipes) |
| TS-0550-3100 | ALS 2-1 Weld flange (for 2 cylinder/2 outlet pipes) |
| TS-0505-3001 | WG40 Inlet Weld Flange (for single outlet) |
| TS-0550-3101 | Inlet Weld Flange AL |
| TS-0550-3102 | Inlet pipe adapter 1-3/4" OD |
| TS-0550-3103 | Inlet pipe adapter 1-1/2" OD |
| TS-0552-3001 | WG40 Valve Seat |
| TS-0552-3003 | WG40 Inlet/WG45 Outlet V-Band |
| TS-0552-3004 | WG40 Outlet V-Band |
| TS-0550-3062 | WG38/40 CG Sensor Cap Black |
| TS-0550-3063 | WG38/40 CG Sensor Cap Blue |
| TS-0550-3057 | HE Sensor Replacement |
| TS-0550-3076 | WG40 weld purge bung |
| TS-0550-3080 | V-Band Replacement Nut - 2 Pack |
| TS-0550-3059 | WG38/40 CG Diaphragm Replacement kit |
| TS-0550-3009 | WG38/40 Actuator Collar |
| TS-0550-3093 | WG Diaphragm replacement tool |

FITTING YOUR GEN V ALV

1 Mounting your New Turbosmart Gen V ALV (Anti Lag Valve)

The weld flanges should be welded to your exhaust system. The weld flanges are compatible with stainless steel and mild steel welding rod material.

For best results tubes should be plumbed into the turbo manifold as close to the exhaust port of the engine for maximum efficiency. Turbosmart Weld flanges are designed to accept 19mm (3/4") tube, large diameter tubes with the least amount of restriction will achieve a higher amount of usable energy in the manifold.

CAUTION!

Do not place the actuator cap near a significant heat source as this could shorten the life of the diaphragm.

CAUTION!

Use of the Antilag valve produces excessive heat in the exhaust manifold and turbo and may result in shorter than expected life.

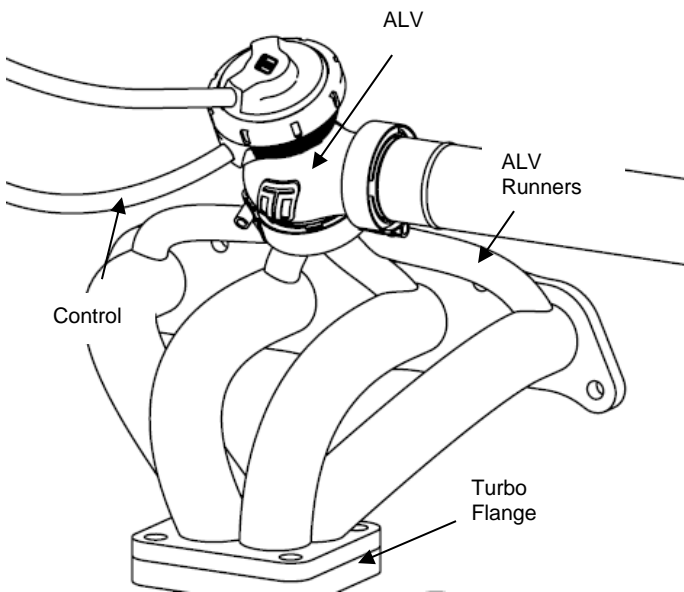

Plumbing the antilag valve into the exhaust port maximises the thermal energy from the exhaust to increase the flame front with fresh air and unburnt fuel.

Connect the inlet of the ALV to the charge intercooler piping pre-throttle body, having the pipe and attached at an angle in the direction of flow may help the efficiency of the system.

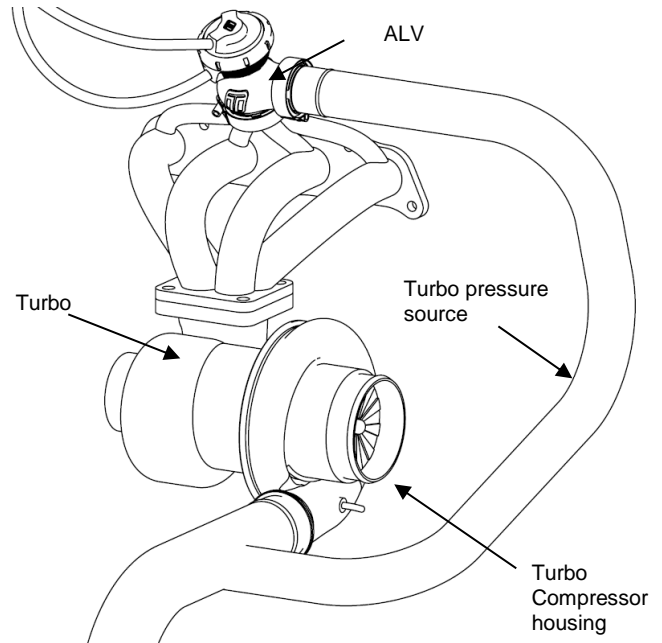

2 Fitting the Gen V ALV

Prior to mounting the Gen V ALV, place v-band over weld on flange by unscrewing the nut on the v-band as far out as possible and then squeezing the bolt in a syringe motion to expand the v-band (squeeze the dots together below). Once the v-band is in its fully expanded position, slide the v-band over the flange to allow for the ALV to be installed.

Do not forget to put the valve seat into the body before mounting the unit on the exhaust manifold. Using the 3/8" deep socket and a torque wrench Tighten the V-Band to 7N.m (5 ft/lbs). Ensure the Anti Lag Valve is home correctly while torquing the nut to not have a false torque as this will likely contribute to exhaust leaks. Ensure O-Ring is in place on the inlet compressed air side of the valve.

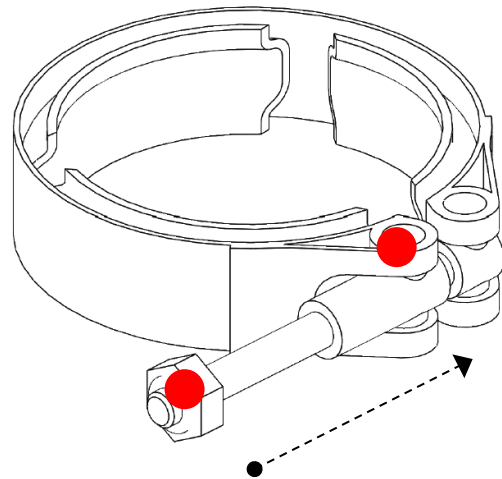

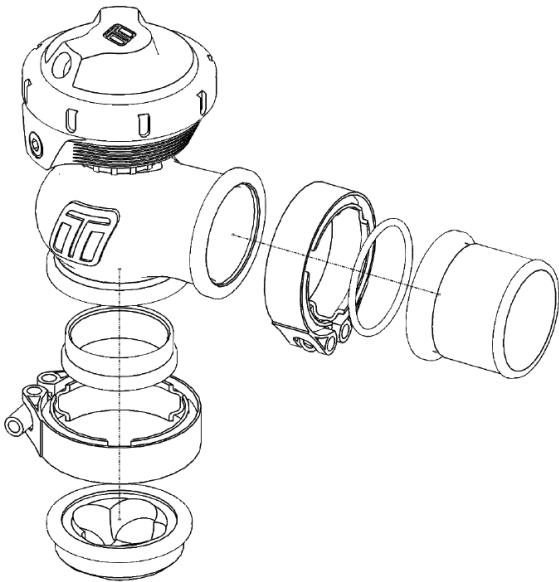

3 Fit Actuator Port Fittings

Fit lower Top and Bottom port fittings prior to mounting the ALV, install 1/8" NPT blank with 3/16" hex key and signal nipple into opposite side ports. Port order or orientation is not important, select which suits your packaging requirements. Apply thread lubricant and screw in clockwise until finger tight, then tighten further 1-2 turns for seal.

NOTE!

If you are unsure which port to install fittings into, please refer to 'Control Hookup' section, refer to table of contents for page number.

4 Control Hookup

Depending in the control strategy of the antilag valve, the hook-up method may vary, below is a couple of examples but is not limited to.

WARNING!

Antilag results in a reduction of vacuum produced which affects the effectiveness of vacuum assist brake boosters.

IMPORTANT!

Antilag requires advanced tuning techniques and specific controls, Turbosmart recommends this system be setup by professionals only.

4.1

Vacuum Pump

When using your Gen V Anti Lag Valve in conjunction with a vacuum pump, fit a 4-port solenoid (**sold separately – TS-0301-2003**) with normally open ports to the bottom port of the solenoid to the bottom port of the valve. Plumb the top port to the switched port A of the solenoid to activate the valve. Your ECU should be configured to open the valve when ALS operation is desired.

- Port A of solenoid to Top port of ALV
- Port B of solenoid to Bottom port of ALV
- EX port of solenoid vent to atmosphere
- IN port of solenoid to Pressure only source

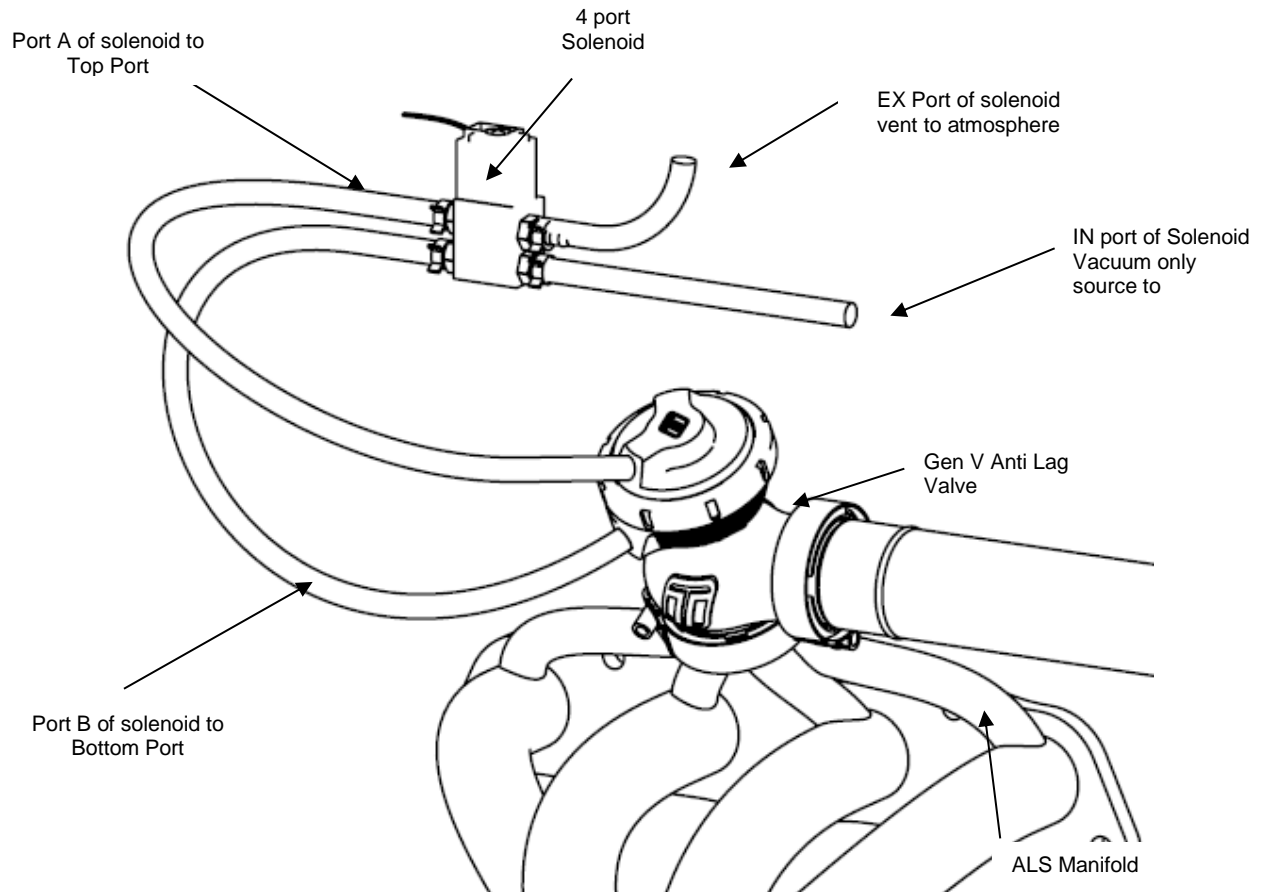

4.2 Compressor

When using your Gen V Anti Lag Valve in conjunction with a air compressor, fit a 4-port solenoid (**sold separately – TS-0301-2003**) with normally open port B to the Top port of the solenoid to the Bottom port of the valve. Plumb the Bottom port to the switched port A of the solenoid to activate the valve. Your ECU should be configured to open the valve when ALS operation is desired.

- Port A of solenoid to Bottom port of ALV
- Port B of solenoid to Top port of ALV
- EX port of solenoid vent to atmosphere
- IN port of solenoid to Pressure only source

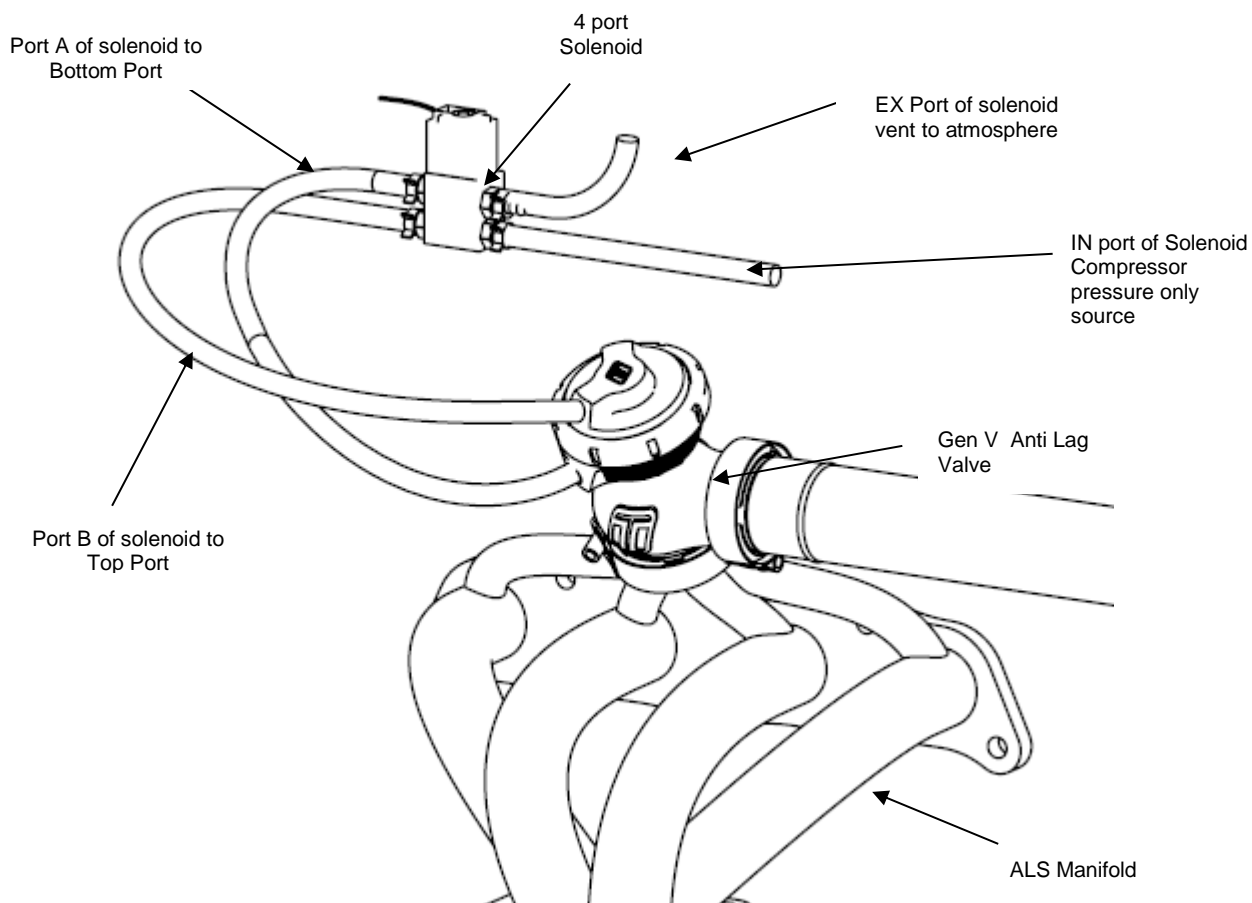

5 Start Engine and Check for Leaks

Congratulations, your Gen V ALV is installed and ready for use. Double check all fittings, lines and mountings then proceed to start engine and check for leaks.

Tuning Strategies

CAUTION!

- Tuning your antilag valve should be done by a professional
- Antilag valve is for race applications only
- The use of antilag creates excessive heat in the exhaust manifold and can shorten the life of turbo, exhaust manifold and related systems

1

Activation and Shut Down

Criteria should be established within the ECU to control the antilag valve, a minimum throttle percentage and delay to arm the system with arming achieved when throttle is released with an active time limit set.

It is a good idea to have limits set up to shut down the antilag system if too much heat is being produced. Exhaust temperature sensors and engine temp should be monitored and allowed to deactivate the system if bordering dangerous levels.

Outputs should be set up to open and close the valve when enabled.

NOTE!

For best results any bypass valves in the system should be forced closed when in enabled.

2

Tuning

Each engine and set up will require different parameters to achieve the desired results. Typically, a combination of ignition retard, ignition cut, and fuel trim can be used to increase and decrease the effectiveness of the system

HOW TO CHANGE YOUR GEN V ALV DIAPHRAGM

Gen V ALV replacement diaphragm kit:

ALV : TS-0550-3059

CAUTION!

- Ensure diaphragm is contained within the groove prior to cap re-assembly.
- Pay attention not to rotate diaphragm.

1

Remove ALV from Manifold

Remove boost pressure source hose from the ALV as well as the breather hose is fitted. Unscrew outlet V-Band nut in a anti-clockwise direction to the very end of the thread, Squeeze the nut against the V-Band in a syringe like motion to expand the V-band over the flange. Repeat for inlet V-Band. Remove Gen V ALV being careful not to lose the valve seat. Mark the orientation of the valve to the body with tape or a paint pen.

CAUTION!

Allow engine to cool down before removing your Gen V ALV

2

Remove Top Cap

Prior to removing the Gen V ALV cap, remove all fittings from the 1/8"NPT ports. Press down on the cap in a press or vice. Unscrew locking collar with the large end of the provided collar tool in an anti-clockwise direction until completely disengaged and slowly remove tension from the press or vice allowing the

spring to expand, finally remove cap when the spring has stopped expanding.

CAUTION!

Use soft jaws to prevent damage

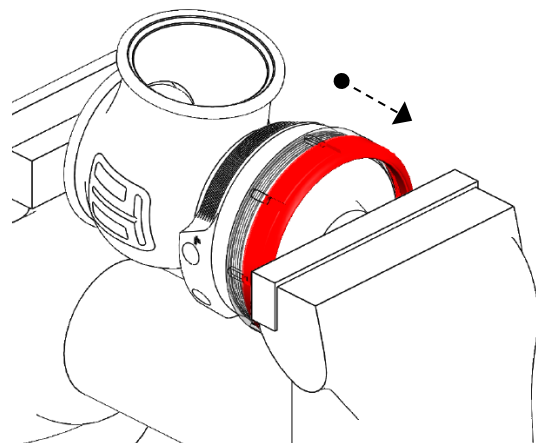

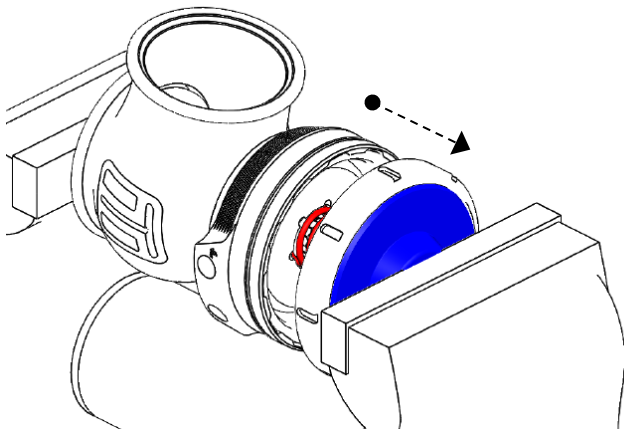

3 Diaphragm Replacement

Use the supplied tool in the diaphragm replacement kit, engage the diaphragm aligning the splines and grooves. Use a 25mm spanner on the tool to prevent the diaphragm from spinning. Use a 12point 14mm socket through the centre of this tool onto the valve retaining cap. Undo the valve retaining cap by rotating in an anti-clockwise direction.

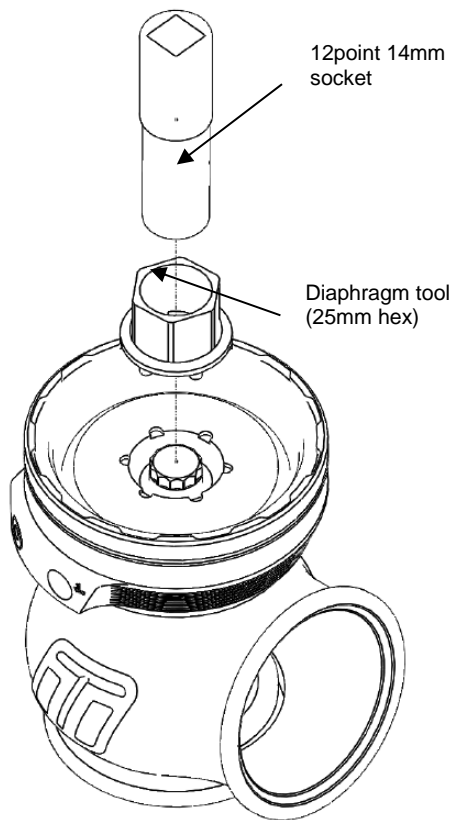

Remove the valve retaining cap and spring washer, Sit the ALV on down so that the valve is elevated and supported. Using a small flat blade screwdriver to pry one edge of the split in the valve circlip out and up, work your way around the circlip until it is removed. Take note of the orientation of the diaphragm, lift the old diaphragm over the valve and discard. Use this opportunity to thoroughly clean the ALV removing any dirt from the actuator,

ensure the diaphragm groove is free of debris and fit your replacement diaphragm over the valve.

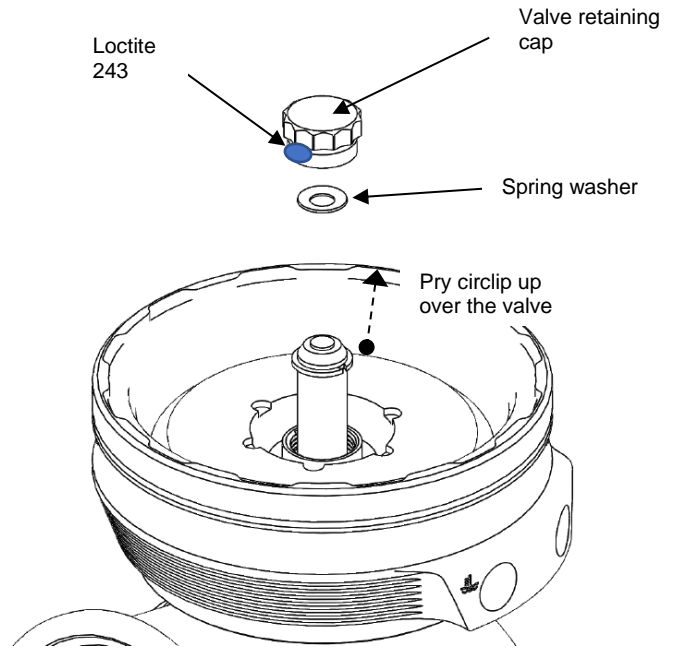

Sit the new valve circlip on top of the valve ensuring it is concentric, Use the valve retaining cap on top of the circlip to lightly press the new circlip over the valve into place, Confirm the circlip is located correctly in the circlip groove of the valve, adjust if necessary. Let the valve drop down into the diaphragm, sit the new spring washer onto the nipple of the valve with the outside of the cone away from the valve. Apply a dab of blue 243 Loctite to the lower threads of the valve retaining cap and screw into the diaphragm. Support the diaphragm with the supplied tool and tighten the valve retaining cap to 20N.m (15ft/lbs)

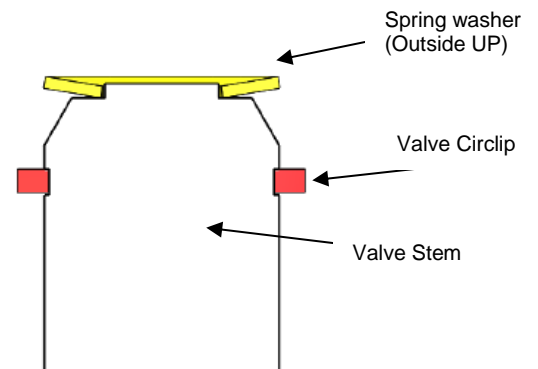
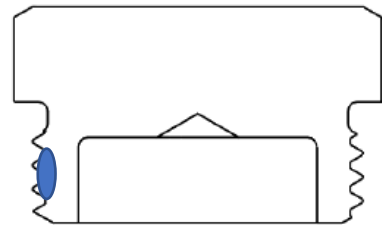

Clockwise to tighten
 Anti-clockwise to loosen
 As viewed from above

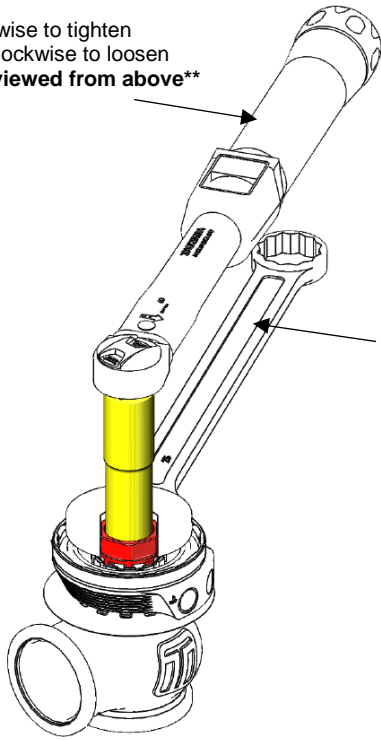

Align the valve orientation marks and confirm the diaphragm bead is seated in the groove of the actuator. Install desired spring combination.

Configure ALV with preferred spring combination of inner, middle and outer springs

4 Familiarise Yourself with Cap and Body Notches

Locate cap and body notches and grooves which dictate the alignment of the cap. These notches are used to locate the cap onto the body and must be aligned prior to compression of the cap onto the body

CAUTION!
 Ensure notches are aligned and seated home correctly prior to exerting force to tighten collar, permanent damage will occur if these are not aligned correctly.

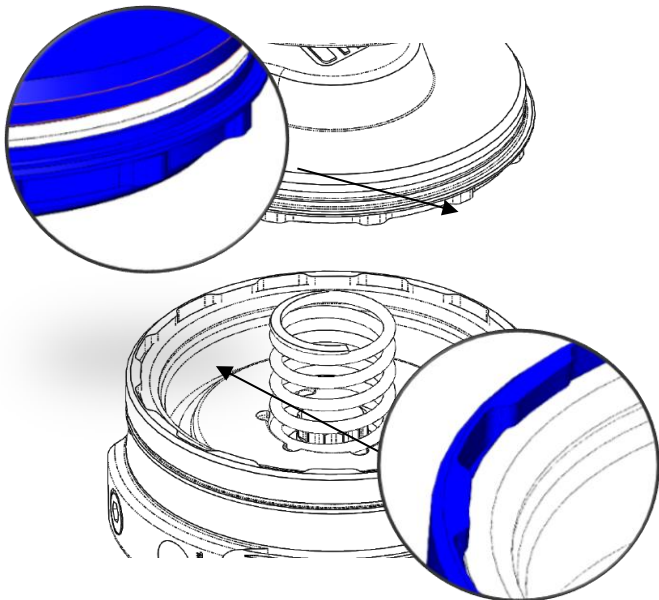

5 Press cap onto body

Using a press or vice, compress the cap onto the body ensuring the notches are remaining aligned. Once the cap has seated home onto the bod, screw the collar down by hand in a clockwise direction. While still in the press or vice, Tighten the collar further with the collar tool until the collar will not turn.

CAUTION!
 Maintain downward pressure on cap while tightening collar or non-repairable thread damage will occur. Hold still

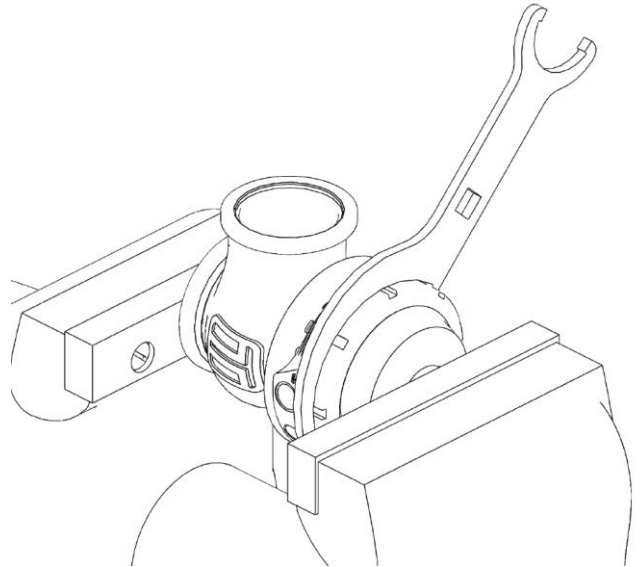

Reinstall fittings to the cap of the ALV using fresh sealant.

6 Reinstall Gen V ALV

Place v-band over weld on flange by unscrewing the nut on the v-band as far out as possible and then squeezing the bolt in a syringe motion to expand the v-band (squeeze the dots together below). Once the v-band is in its fully expanded position, slide the v-band over the flange to allow for the ALV to be installed.

Do not forget to put the valve seat into the body before mounting the unit on the ALV manifold. Using the 3/8" deep socket and a torque wrench Tighten the V-Band to 7N.m (5 ft/lbs),

HOW TO INSTALL A SENSOR CAP TO YOUR GEN V ALV

CAUTION!

- Ensure diaphragm is contained within the groove prior to cap re-assembly.
- Pay attention not to rotate diaphragm.
- Cool air flow is required around the actuator to keep the sensor in its operating window.

1 Remove ALV from Manifold

Remove boost pressure source hose from the ALV as well as the breather hose is fitted. Unscrew outlet V-Band nut in a anti-clockwise direction to the very end of the thread, Squeeze the nut against the V-Band in a syringe like motion to expand the V-band over the flange. Repeat for inlet V-Band. Remove Gen V ALV being careful not to lose the valve seat or O-Ring. Mark the orientation of the valve to the body with tape or a paint pen.

CAUTION!

Allow engine to cool down before removing your Gen V ALV

2 Remove Top Cap

Prior to removing the Gen V ALV cap, remove all fittings from the 1/8"NPT ports. Press down on the cap in a press or vice. Unscrew locking collar with the large end of the provided collar tool in an anti-clockwise direction until completely disengaged and slowly remove tension from the press or vice allowing the spring to expand, finally remove cap when the spring has stopped expanding.

CAUTION!

Use soft jaws to prevent damage

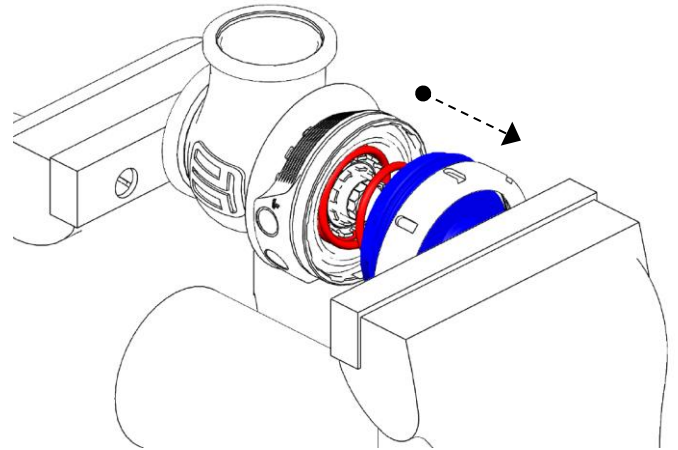
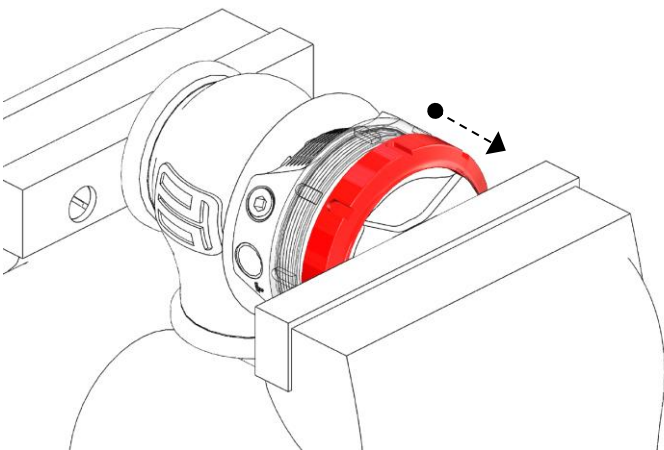

2 Diaphragm Replacement

Use the supplied tool in the diaphragm replacement kit, engage the diaphragm aligning the splines and grooves. Use a 25mm spanner on the tool to prevent the diaphragm from spinning. Use a 12point 14mm socket through the centre of this tool onto the valve retaining cap. Undo the valve retaining cap by rotating in an anti-clockwise direction.

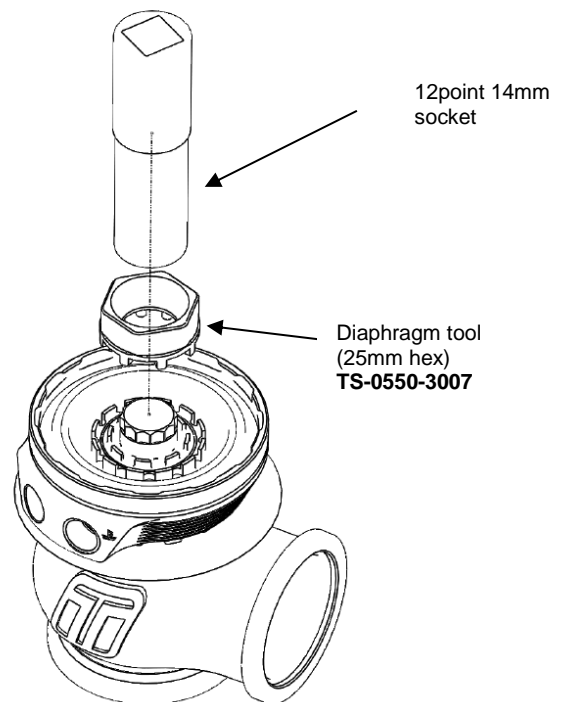

Clear any Loctite and debris from the thread in the diaphragm support, Note careful not to get chemicals onto the diaphragm as this may damage the diaphragm.

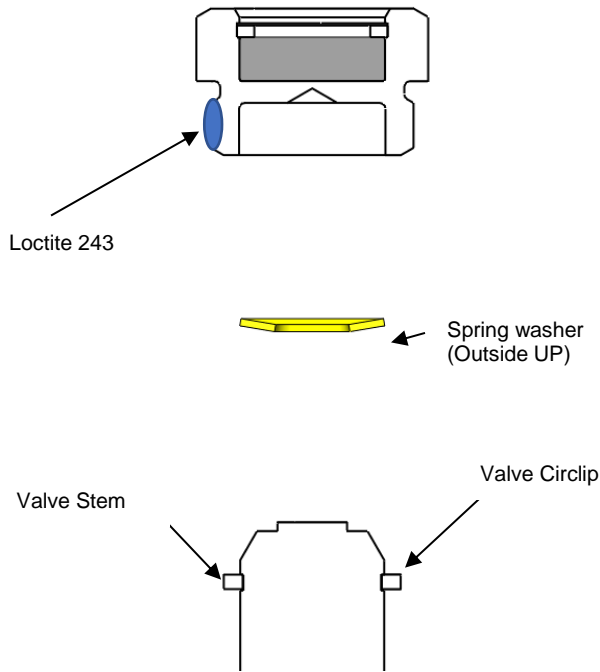

Sit the new spring washer into the valve retaining cap with the centre of the washer pointing out of the cap. Apply a dab of blue 243 Loctite to the lower threads of the valve retaining cap and screw into the diaphragm. Support the diaphragm with the supplied tool and tighten the valve retaining cap to 20N.m (15ft/lbs)

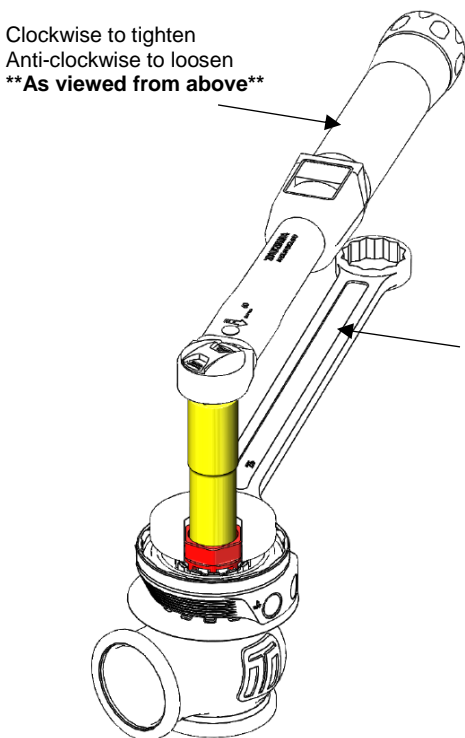

Align the valve orientation marks and confirm the diaphragm bead is seated in the groove of the actuator. Install desired spring combination.

Configure ALV with preferred spring combination of inner, middle and outer springs

3 Familiarise Yourself with Cap and Body Notches

Locate cap and body notches and grooves which dictate the alignment of the cap. These notches are used to locate the cap onto the body and must be aligned prior to compression of the cap onto the body

CAUTION!

Ensure notches are aligned and seated home correctly prior to exerting force to tighten collar, permanent damage will occur if these are not aligned correctly.

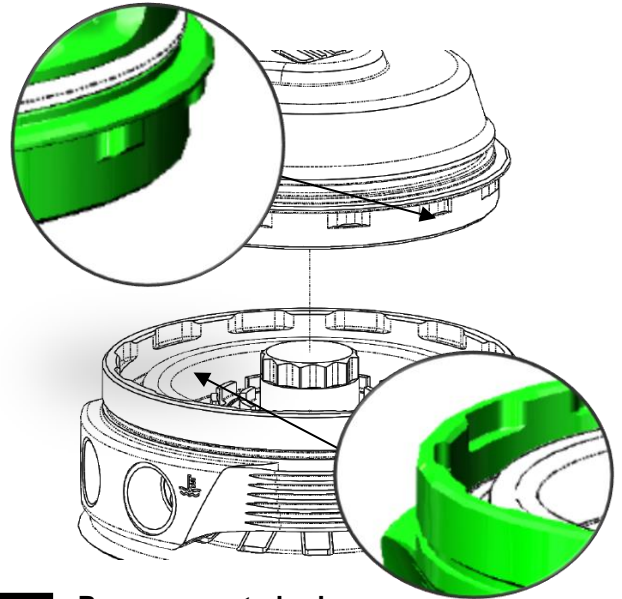

4 Press cap onto body

Using a press or vice, compress the cap onto the body ensuring the notches are remaining aligned, use spacers to ensure the wire from the sensor is not crimped or damaged. Once the cap has seated home onto the body, screw the collar down by hand in a clockwise direction. While still in the press or vice, Tighten the collar further with the collar tool until the collar will not turn.

CAUTION!

Maintain downward pressure on cap while tightening collar or non-repairable thread damage will occur. Take care not to damage the wire during assembly.

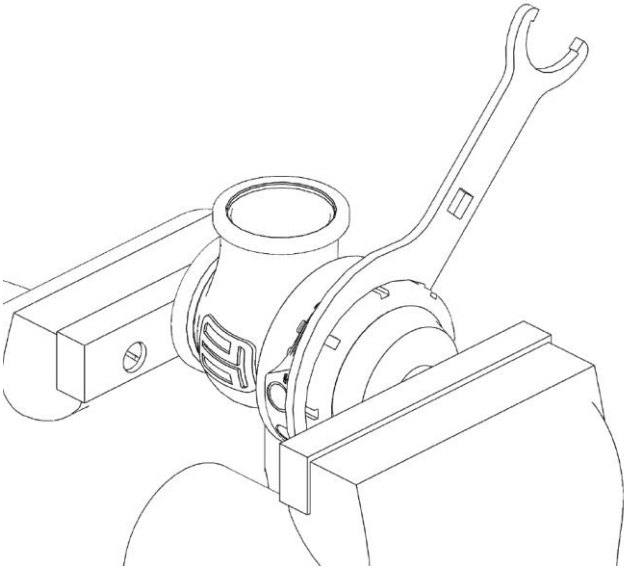

Reinstall fittings to the cap of the ALV using fresh sealant.

5 Reinstall Gen V ALV

Place v-band over weld on flange by unscrewing the nut on the v-band as far out as possible and then squeezing the bolt in a syringe motion to expand the v-band (squeeze the dots together below). Once the v-band is in its fully expanded position, slide the v-band over the flange to allow for the ALV to be installed.

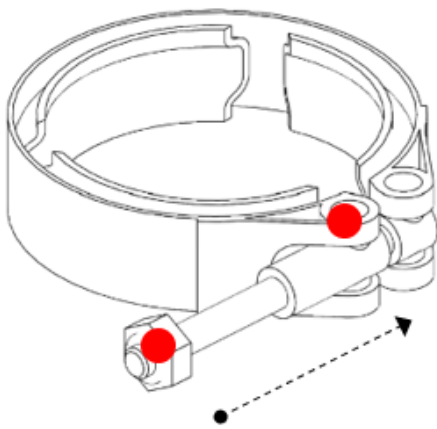

CAUTION!
Do not forget to place valve seat into the body before mounting the ALV on the exhaust manifold. Use a 3/8" deep socket and torque the V-Band to 7N.m (5 ft/lbs)

6 Wiring

Your new Turbosmart sensor cap comes with sensor pre-installed into the cap with unterminated wires for you to fit the connector of your choice.

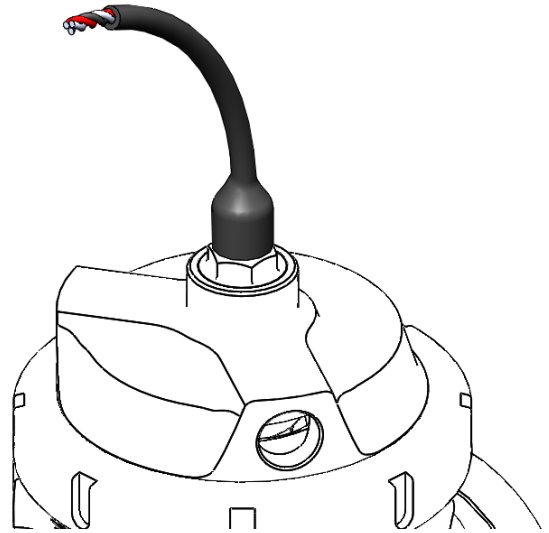

| Wire | Note | Rating |
|-------|-----------------------------|------------------|
| Red | Sensor Supply (V_{sup}) | 4.5-5.5 V_{dc} |
| Black | Sensor Ground (V_0) | 0V |
| White | Sensor Output (V_{out}) | 0- V_{supply} |

Connect the wires to your data logger accordingly. Use a high-quality connection to reduce noise and calibration fluctuation.

Ensure that the wiring is properly shielded from external heat sources.

CAUTION!
To ensure longevity from the sensor, ensure adequate airflow is supplied directly to the sensor to avoid overheating or sensor failure.

Turbosmart HE sensor has an operation temperature window of -40C up to 170°C (340°F) junction temperature, for temperatures outside of this window the V_{OUT} will revert to less than 2.5V

Temperature exposure above 260°C (500°F) can cause permanent damage to the sensor.

7

Calibration*

Insert the relevant calibration curve into your data logger for the product family you have

Turbosmart Gen V ALV

| Valve Lift (mm) | V _{OUT} |
|-----------------|------------------|
| -0.75 | 2.221 |
| 0.5 | 2.138 |
| 1.75 | 2.03 |
| 3 | 1.88 |
| 4.25 | 1.692 |
| 5.5 | 1.454 |
| 6.75 | 1.126 |
| 8 | 0.683 |
| 9.25 | 0.118 |
| 10 | 0.003 |

***NOTE!** For best results, each ALV should be calibrated to your setup.

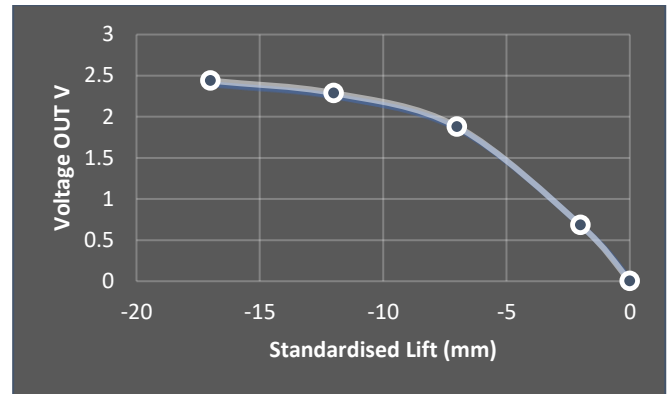

TROUBLE SHOOTING

- ALV not actuating - Confirm preload on valve seat during installation
 - Poor ALV actuation - Ensure signal hose is connected to a quality pressure source, check seal on fittings
 - Poor ALV actuation - Confirm ports are not blocked and free from debris
-