

Product Name: BOV Controller Kit
 Product Description: Electronic BOV controller
 Product Number: TS-0304-100X



IMPORTANT NOTES:

- Please thoroughly read and understand these instructions before commencing this installation.

RECOMMENDATIONS

- **Turbosmart recommends that your BOV controller is fitted and adjusted by an appropriately qualified technician**
- **Turbosmart recommends that a boost gauge be permanently fitted to the vehicle**

Please check that the following items have been provided in your BOV Controller Kit

Quantity	Description	Use
1	BOV Controller Unit	BOV Controller
1	Race Port assembly	Blow off valve fitted with orange inner spring and stainless steel weld flange
2m	2 core wire	Connect BOV Controller to solenoid
1	Heat shrink	Insulating soldered joints
2	Double sided adhesive	Surface mounting BOV controller
2	M3 X 30 Screws	Mounting BOV controller
2	M3 Nuts	Mounting BOV controller
1	3 Port solenoid	Controls pressure to BOV
3	1/8 NPT nipples	Connects solenoid to hose
1.2m	6.3mm Reinforced pressure tube	To connect the solenoid to the BOV
1	Solenoid Bracket	Mounting the solenoid
2	M3X20 SHCS	Mounting bracket to solenoid
2	5 amp Fuses	To protect the BOV controller and solenoid from voltage problems
1	M6 Nut	Secure solenoid bracket to car
1	M6 X 25 SHCS	Secure solenoid bracket to car
1	M6 Washer	Secure solenoid bracket to car
10	Cable ties	Securing vacuum tube and wires
1	Crimp ring terminal	For ground connection
4	Hose clamps	Securing all pressure lines
1	8 way wiring loom	Connects BOV Controller to devices and power

FUNCTIONALITY

The BOV controller works by detecting a negative voltage change in throttle position. It then energises the solenoid to vent all of the air out of the BOV cap, causing a pressure differential between the piston of the BOV and the cap which will vent pressure from the intake system. There are 2 parameters that can be adjusted to tune the controller for optimum performance; duration and sensitivity. The green LED shows that the BOV controller is on. The yellow LED shows when the solenoid is activated.

LAYOUT

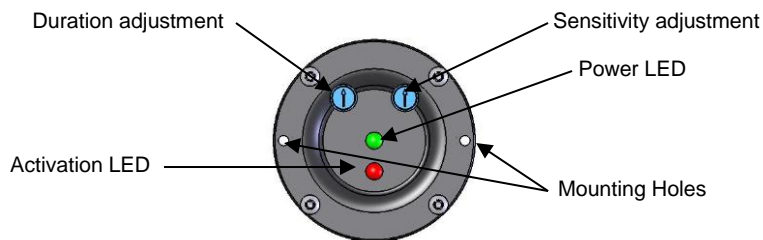

INSTALLATION

Mount the unit away from any heat source and moisture. Wire up the unit as per diagram. Do not connect the unit to a power supply which will have a greater voltage than 14V DC. **Unused wires must be insulated with electrical tape so that they do not touch other wires or the chassis**

1. ORANGE = +5V (For external TPS) – **OPTIONAL if your engine does not have a OEM TPS**
2. GREEN = 0V (For external TPS) - **OPTIONAL if your engine does not have a OEM TPS**
3. WHITE = TPS signal Input
4. YELLOW = Solenoid trigger signal
5. GREY = Disable Trigger wire (Ground to disable Controller) - **OPTIONAL**
6. BROWN = Enable Trigger wire (Ground to keep solenoid energised) - **OPTIONAL**
7. BLACK = Controller Ground
8. RED = +12V (**USE SUPPLIED 5A Fuse inline**)

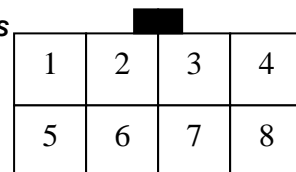

Looking into BOV Controller

SOLENOID CONNECTION

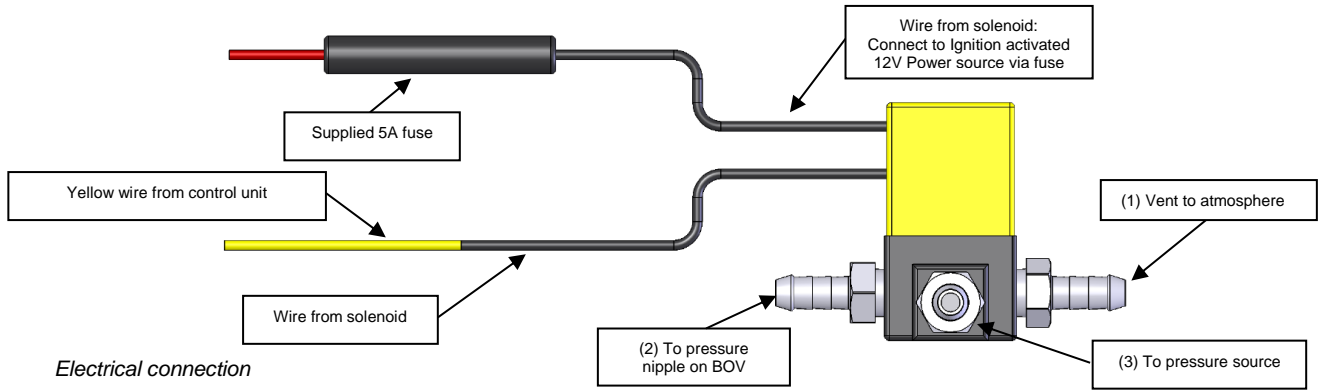

Electrical connection

Connect one wire of the solenoid to a fused (**use supplied fuse**) ignition activated 12V power source and connect the other wire to the Solenoid trigger signal (Yellow) on the BOV controller unit. Polarity is not important.

Pressure connection

Port 1: Vent to atmosphere.

Port 2: To pressure nipple of BOV.

Port 3: To pressure source e.g. Intercooler piping (Make sure the pressure source is not shared and that it is from the same part of the pipe work as the BOV)

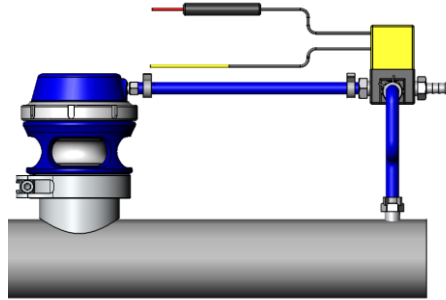

MOUNTING YOUR BOV

- Allow the engine to cool down before installing your BOV

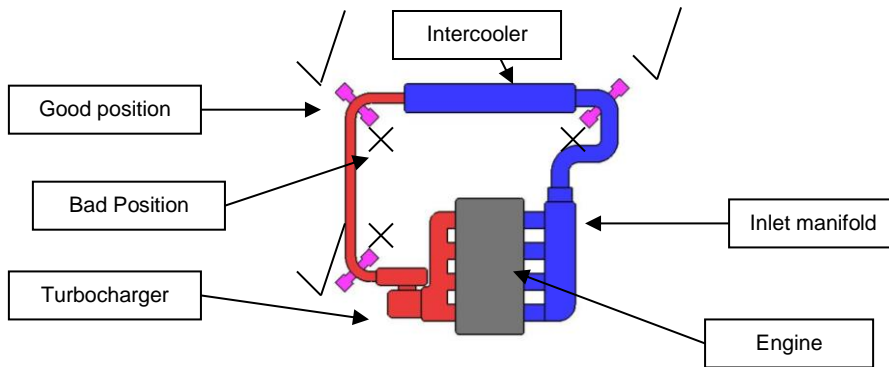

- Connect Port 2 of the solenoid to the pressure nipple of the BOV.
- Secure all silicone hose ends with correct clamps
- Start the engine and check for air leaks in the system

THROTTLE POSITION CONNECTION

The BOV controller can be wired to the existing throttle position sensor on your vehicle. Connect the white wire to the signal output wire from the existing throttle position sensor.

(OPTIONAL) For vehicles without a standard throttle position sensor (such as the 12V Cummins Diesel engine), an external one can be wired in. The **ORANGE AND GREEN** must be used to power the external throttle position sensor if one needs to be installed as the TPS requires a 5V power supply and not a 12V power supply.

SWITCHED INPUT CONNECTION (OPTIONAL)

If your vehicle does not have a standard throttle position sensor and you do not want to install an external throttle position sensor, a double throw switch can be used to activate the BOV. The switch needs to ground the **GREY WIRE ONLY** when the accelerator pedal is pressed in and needs to ground the **BROWN WIRE ONLY** when the accelerator pedal is released.

ADJUSTING YOUR BOV CONTROLLER

DURATION: The duration is the length of time that the solenoid blocks the pressure signal to the BOV. The longer the duration, the longer the BOV will not have pressure supplied to the cap, essentially keeping the BOV open. The controller also has an override function which reactivates the BOV once it detects positive throttle movement, independent of what the duration is set at.

SENSITIVITY: The sensitivity setting determines how the BOV controller reacts to throttle movement. The controller will only activate on negative changes in throttle. The higher the sensitivity setting, the lower the negative change in throttle movement needs to be before the solenoid will activate the BOV e.g. a change from 4V to 3.5V will not activate the valve but from 4V to 3V will activate the valve.

(OPTIONAL IF SWITCHED INPUT CONNECTION METHOD IS NOT USED) ENABLE FUNCTION: Grounding the **BROWN WIRE** activates the enable function which allows the BOV controller to keep the solenoid activated. Even though the unit is still reading changes in throttle position, it will not respond to them, not allowing pressure to reach the top of the BOV. The yellow LED will stay on when this function is activated. This function can be used to limit boost as the BOV will not have any pressure keeping it closed. It can also be used as an over boost safety feature when connected to another device such as a data logger or ECU which can ground the wire if a over boost scenario is reached.

(OPTIONAL IF SWITCHED INPUT CONNECTION METHOD IS NOT USED) DISABLE FUNCTION: Grounding the **GREY WIRE** will activate the disable function which disables the BOV controller. The BOV controller is still switched on but will not respond to changes in throttle position, keeping pressure to the top of the BOV, not allowing the BOV open. This can be used when the BOV is not required to be functional e.g. when using cruise control, the BOV will not actuate on sudden throttle changes cresting hills.

RACE PORT SPRING REPLACEMENT (OPTIONAL)

The Race Port is fitted with an orange inner spring which is suitable for most applications but additional springs can be installed to ensure the valve is closed if you are experiencing the valve opening under boost conditions.

- 1) Remove the Race Port off the intake piping
- 2) Remove any pressure nipples and port blanks in the top cap. Hold the cap down in a press or vice. Unscrew the locking collar. Slowly, back off the vice or press and remove the cap.
- 3) Select and install the required spring or combination of inner and outer springs into the piston assembly.
- 4) Ensure that the diaphragm is inside the diaphragm groove.
- 5) Slowly push the top cap down on the lower diaphragm housing in a vice or press. As the cap reaches the diaphragm, line up the notches in the cap (Figure 1) with the cut outs (Figure 2) in the lower diaphragm housing. Carefully push the cap down till the cap is home on the lower diaphragm housing. Reinstall the locking collar. Make sure that the cap is clamped down while tightening the collar

