



TURBOSMART PRODUCT CATALOG 2017



## MESSAGE FROM THE CEO

Thank you for picking up the new Turbosmart catalog. 2017 is going to be a massive year for us, as Turbosmart celebrates its 20th anniversary. We will look back on 20 fantastic years of innovation and growth, and we will continue to look towards the future, as we release some revolutionary new products that will cement our reputation as an innovator and market leader.

It's hard for me to believe how far Turbosmart has come in its twenty years of manufacturing. Back in 1997, we started as a two man team, hand building blow-off valves and boost controllers in our spare time. Today, we have a large, modern manufacturing facility, fitted out with state of the art machinery, and our dedicated team spans across all corners of the globe. Our ever-growing offices in the USA and UK have allowed us to develop a truly global range of products, bringing the Turbosmart brand to more people in more places than ever before. Some things have remained the same, though - we still proudly manufacture all our products in Sydney, we still have motorsport and performance in our blood, and we are still focused on continuous improvement, so we remain at the top of our game.

To mark our 20th anniversary, Turbosmart has some exciting things in store for the year ahead. We will release a range of exciting new products that will keep Turbosmart at the forefront of the turbo performance product market. And we will celebrate 20 years of Australian manufacturing, market leading innovation and record breaking performance by telling the Turbosmart story in a new and exciting way.

We don't want to give too much away, so you're just going to have to watch this space!

I want to give a sincere thank you to our loyal customers, business partners, sponsored drivers and anyone who has helped Turbosmart along the way over the past 20 years. Whether you've been there with us since the start, or only just joined us, we couldn't have done it without you. So thank you for coming with us on this journey.

Nic Cooper



# CONTENTS

<b>TURBOSMART APP</b> .....	3
<b>BLOW-OFF VALVES</b> .....	4
Which Bov Is Right For My Application? .....	4
Where Should I Mount My Blow-Off Valve?.....	4
Power Port.....	5
Race Port .....	6
Race Port Sensor Cap.....	6
Type 5 .....	7
Smart Port Technology.....	7
Supersonic .....	7
Plumb Back .....	8
Dual Port.....	8
Vee-Port Pro .....	9
Big Bubba.....	9
Kompact .....	10
Blow-Off Valve Controller .....	11
<b>BLOW-OFF VALVE SPRING CHARTS</b> .....	12
Kompact Springs .....	12
Type 5 Springs.....	12
Vee-Port Pro Springs .....	12
Race Port Springs .....	12
Big Bubba Springs .....	12
<b>BLOW-OFF VALVE PARTS AND ACCESSORIES</b> .....	13
Kompact Bov Parts And Accessories .....	13
Type 5 Parts And Accessories.....	13
Type 5 & Vee Port Pro Mounting Accessories And Blanking Plugs.....	13
Race Port Parts And Accessories .....	14
Power Port Parts And Accessories .....	14
Vee Port Pro Parts And Accessories .....	14
Big Bubba Parts And Accessories .....	14
<b>EXTERNAL WASTEGATES</b> .....	15
What Is An External Wastegate? .....	15
Which Wastegate Is Right For My Application?.....	16
Where Should I Mount My Wastegate? .....	16
Ultra-Gate38.....	17
Comp-Gate40.....	18
Hyper-Gate45 .....	19
Pro-Gate50 Lite.....	20
Pro-Gate50 .....	21
Power-Gate60.....	22
Sensor Caps .....	22
HP Wastegates.....	23
<b>INTERNAL WASTEGATE ACTUATORS</b> .....	24
What is an Internal Wastegate Actuator? .....	24
High Pressure Internal Wastegate Actuator .....	24
Twin Port Actuator (NEW).....	24
<b>WASTEGATE SPRING CHARTS</b> .....	25
Internal Wastegate Actuator Springs, Ultra-Gate38 Springs,.....	25
Comp-Gate40 Springs, Hyper-Gate45 Springs & Pro-Gate50 Lite Springs .....	25
Pro-Gate50 Springs & Power-Gate60 Springs.....	26
HP Gate Springs .....	26
<b>WASTEGATE PARTS AND ACCESSORIES</b> .....	27
Ultra-Gate38 Parts And Accessories, Comp-Gate40 Parts And Accessories, .....	27
Hyper-Gate45 Parts And Accessories, Pro-Gate50 Lite Parts And Accessories .....	27
Ultra-Gate38 Mounting Accessories .....	27
Comp-Gate40 Mounting Accessories .....	27
Hyper-Gate45 Mounting Accessories.....	27
Pro-Gate50/Pro-Gate50 Lite Mounting Accessories.....	27
Pro-Gate50 / Power-Gate60 Parts And Accessories .....	27
Power-Gate60 Mounting Accessories .....	28
<b>INTERNAL WASTEGATE PARTS AND ACCESSORIES</b> .....	28
<b>BORG WARNER EFR SERIES TURBO ACCESSORY FITMENT GUIDE</b> .....	28
<b>BOOST CONTROLLERS</b> .....	29
Manual Boost Controllers .....	29
Electronic Boost Controllers.....	29
e-BoostHP .....	30
e-Boost2 .....	30
e-Boost Street.....	31
<b>MANUAL BOOST CONTROLLER PARTS AND ACCESSORIES</b> .....	31
<b>ELECTRONIC BOOST CONTROLLER PARTS AND ACCESSORIES</b> .....	31
<b>FUEL CUT DEFENDERS</b> .....	32
What is Fuel Cut?.....	32
FCD-1 (pneumatic).....	32
FCD-2 (electronic).....	32
<b>GAUGES</b> .....	33
Electronic Gauges .....	33
Mechanical Boost Gauges.....	33
<b>BOOST REFERENCE ADAPTERS</b> .....	34
<b>FUEL PRESSURE REGULATORS</b> .....	35
What is a Fuel Pressure Regulator?.....	35
Which Fuel Pressure Regulator is right for my application? .....	35
FPR800 .....	36
FPR1200 .....	36
FPR2000 .....	36
<b>FUEL PRESSURE REGULATOR PARTS AND ACCESSORIES</b> .....	36
<b>FUEL RAIL ADAPTERS</b> .....	37
<b>FUEL FILTERS</b> .....	38
<b>OIL PRESSURE REGULATORS (OPRS)</b> .....	39
Turbo Oil Pressure Regulators.....	39
<b>TURBO OIL FEED FILTERS AND DRAIN ADAPTERS</b> .....	39
<b>SILICONE HOSE</b> .....	41
Why Upgrade To Silicone? .....	41
Straight Hose - Pre-Cut Lengths .....	41
Straight Hose - Full Lengths .....	41
45 Degree Elbows .....	42
90 Degree Elbows .....	42
Vacuum Hose .....	43
Reinforced Vacuum Hose.....	43
Reinforced Hump Hoses.....	43
Silicone Tees .....	43
Straight Reducers.....	44-45
45 Degree Elbow Reducers .....	45
90 Degree Elbow Reducers .....	45
<b>HOSE CLAMPS AND BLANKING PLUGS</b> .....	45
Murray Turbo Seal Series Constant Tension Clamps.....	45
<b>MAKE/MODEL PRODUCT FITMENT GUIDE</b> .....	47-59

# TURBOSMART APP

## TURBOSMART APP **NEW**

The Turbosmart experience is waiting at your fingertips with the handy new Turbosmart app for iPhone and Android. Take the guesswork out of finding the right wastegate for your application with our wastegate size calculator. The calculator takes into account your engine size, turbo type, boost level and desired power level to provide you with a recommendation of the right wastegate for your vehicle.

The app also brings fitting instructions directly to your phone, while also providing personalised product recommendations for your vehicle.





## TURBOSMART BLOW-OFF VALVES

A Blow-Off Valve, sometimes called a diverter valve or bypass valve, is a pressure relief valve that is mounted between the turbo and the intake manifold. It releases excess air pressure when the vehicle comes off throttle.

A Blow-Off Valve is an essential part of a turbocharger system, as it prevents damaging turbo compressor surge that can be present on rapid throttle and/or engine load changes, it also increases the response of the turbocharger by not over-slows the turbine.

All TurboSmart Blow-Off Valves are made entirely from billet aluminium, so they will never crack and leak like cast or plastic units do. They also improve boost response from the turbocharger.

### WHICH BOV IS RIGHT FOR MY APPLICATION?

Several factors need to be considered when choosing the correct Blow-Off Valve, including the performance requirements, and desired power level. As a rule of thumb, big power needs a big Blow-Off Valve to move more air, whereas lower power needs a smaller Blow-Off Valve for precise control. If you like things loud, choose a vent-to-atmosphere Blow-Off Valve, or if you prefer to keep it stealthy, a plumb back Blow-Off Valve will be much quieter, and just as effective.

TurboSmart makes five different types of Blow-Off Valves, each with their own set of unique benefits.

**Kompact:** Designed as a bullet-proof replacement for OEM parts - where space is at a premium.

**Type 5:** Designed as a high flow/performance alternative to OEM parts, or custom turbo set-ups. Type 5 valves are well suited for both street vehicles and race machines.

**Vee-Port PRO:** Maximum performance in a light weight, compact package. Ideal for performance situations where space is limited, such as boosted motorcycle or powersports applications.

**Race Port:** A pure high performance motorsport Blow-Off Valve. Very high flowing and light weight.

**Big Bubba:** Size matters! Designed for twin turbo and supercharged V8s, and large capacity modified turbo-diesel engines.

**Power Port:** The largest and highest flowing blow-off valve ever. The ultimate accessory for ultra-high-power turbocharged drag racing purposes. Light weight and Ultra High flowing.

### WHERE SHOULD I MOUNT MY BLOW-OFF VALVE?

A Blow-Off Valve can be mounted anywhere, just as long as it is big enough to flow enough air to keep the turbocharger from suffering compressor surge. Where the Blow-Off Valve isn't mounted directly to the compressor cover, we recommend the BOV be installed along the intercooler/intake piping, ideally after the intercooler and as close to the throttle body as possible. Doing this means airflow through the intake system continues to flow towards the intake manifold when the throttle is shut and the Blow-Off Valve is venting, but when the throttle is reopened, air is still travelling in the same direction requiring less energy and time for the turbocharger to return to operating speeds.

## TurboSmart BOV vs OEM BOV

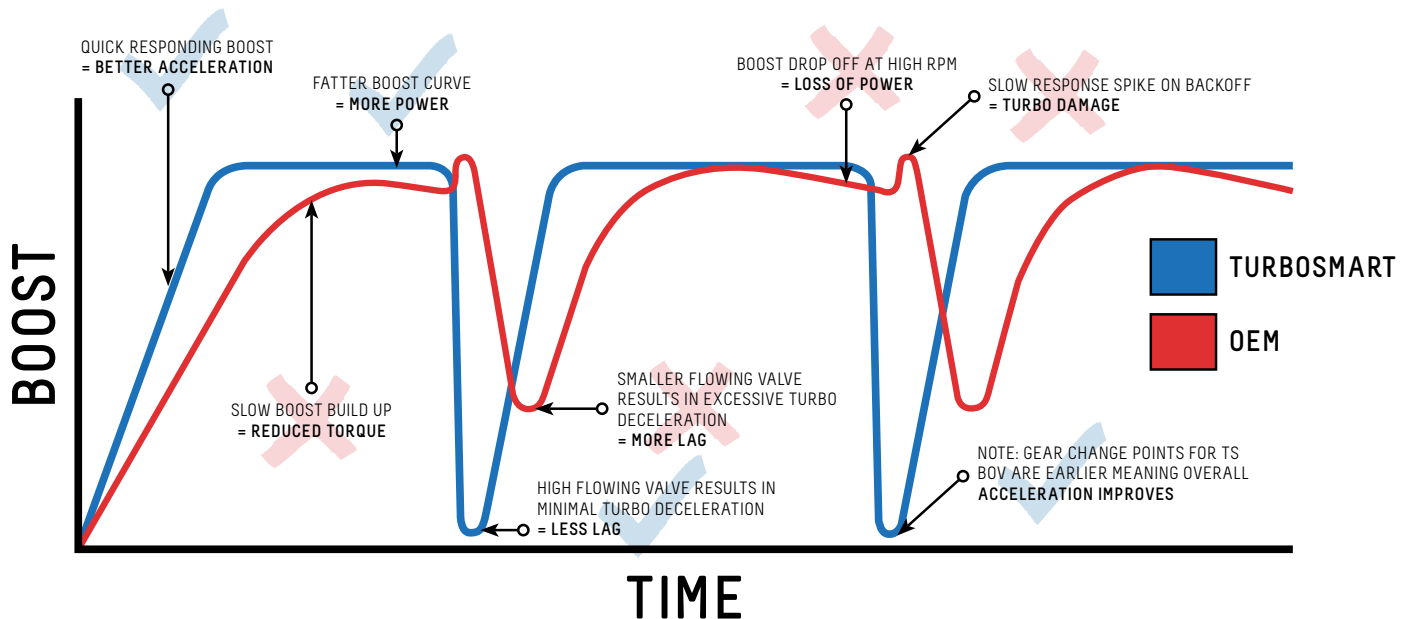

# BLOW-OFF VALVES



## POWER PORT NEW

The Power Port is TurboSMART's largest and highest flowing blow-off valve ever, resetting the flow benchmark set by our popular and highly regarded Race Port BOV. The Power Port's massive 2.5in inlet, unprecedented valve lift, supersized ports and carefully designed CFD flow-paths mean it has more than enough breathing room for even the most powerful turbocharged drag racing engines, preventing damaging compressor surge and throttle plate damage at the end of the quarter mile, even at the most extreme boost levels. The Power Port is designed to be as light as possible, to keep vehicle weight down.

Its cutting edge dual-chamber design means it can be held open with the use of a solenoid to aid turbo response and control during staging to give the best possible launch.

The Power Port is also available with a sensor cap, which can be used to log valve position. This is ideal for custom tuning applications, replacing guesswork with reliable data.

Power Port Part Numbers	
TS-0207-1001	Power Port - Blue
TS-0207-1002	Power Port - Black
TS-0207-1101	Power Port with Sensor Cap - Blue
TS-0207-1102	Power Port with Sensor Cap - Black





## RACE PORT

The Race Port is a true high performance and motorsport-oriented BOV. It is perfect for the tough conditions of track use, and absolutely untouchable in a street application.

This full-time vent-to-atmosphere Blow-Off Valve:

- 2in inlet diameter for high horsepower engines
- Is extremely high flowing for its size
- Is the lightest and smallest valve of its type on the market
- Is diaphragm operated for unbeatable response
- Has a large variety of springs available for custom applications

Race Port Part Numbers	
TS-0204-1101	Race Port - Blue
TS-0204-1102	Race Port - Black

For spring charts go to page 12

For spares and accessories go to page 13

## RACE PORT SENSOR CAP NEW

The Race Port Sensor Cap allows you to upgrade your existing (locking collar-style) Race Port Blow-Off Valve to obtain data via an analog position sensor. Compatible with a wide range of popular data loggers, the Race Port Sensor Cap is a highly versatile innovation in forced induction tuning.

The Sensor Cap gives you first-hand, in depth understanding of Blow-Off Valve behaviour under any engine operating condition. Information such as Blow-Off Valve reaction time, and valve position versus manifold pressure, can be readily obtained. This data can in turn be utilised to maximise turbocharger performance.

Race Port Sensor Cap Part Numbers	
TS-0204-3107	Race Port Sensor Cap - Blue
TS-0204-3108	Race Port Sensor Cap - Black
TS-0502-2008	Sensor
TS-0502-2009	Sensor plug



# BLOW-OFF VALVES

## TYPE 5

The Type 5 line up is Turbosmart's most popular range. The Type 5 38mm/1.5in valve has been designed for high flow and performance. Type 5 valves are well suited for both street vehicles and race machines. The Type 5 line features:

- **Clever modular design** – all Type 5 Blow-Off Valves are simple to take apart and modify. Want to turn your vent-to-atmosphere Blow-Off Valve into a plumb back valve? It can be done in a matter of minutes! Trumpets can be unscrewed and swapped for blanking plugs and hose fitting, or back the other way. Likewise inlet flanges, hose fittings and vee-band fittings, are all interchangeable
- **Precision machining and assembly** – Each Type 5 Blow-Off Valve features a tolerance-matched piston and body, which ensures a precise fit between the moving parts, eliminating the need for a body to piston o-ring seal. Thus, providing excellent piston response and reliability over other designs. An o-ring seal is installed at the base of the piston, where it is most needed, to provide a positive seal against boost pressure and remove the possibility of false knock.

## SMART PORT TECHNOLOGY

The Smart Port is a revolutionary Blow-Off Valve design, combining precision construction with state of the art materials to give unrivalled valve performance. The Smart Port's unique piston is made from an aerospace alloy with a military-spec coating, ensuring its weight and friction are as low as possible, resulting in quicker valve response, better sealing and superior durability.

Its benefits include:

- Drive-by-wire friendly staging technology, eliminating compressor surge at both low and high RPM while integrating smoothly with the car's factory engine mapping
- A hard-anodised, lightweight, aluminium piston providing better valve response and prolonged piston life
- New Smart Port trumpet design which allows the use of a softer spring in the body of the BOV to aid valve response to the plumb back port, while still retaining the ability to vent to atmosphere

The Smart Port is currently available on Type 5 BOVs to suit a wide range of vehicles.

Model Specific Type5 Smart Port BOVs & BPVs Part Numbers	
TS-0215-1041	Smart Port 2.0L VAG Golf R/S3 BOV - Black
TS-0215-1018	Smart Port Subaru WRX 2015-current - Black
TS-0215-1367	Smart Port Supersonic BOV - Ford F150 3.5 EcoBoost 2013 + - Black
TS-0215-1027	Smart Port Dual Port Nissan GT-R R35 Kit
TS-0215-1022	Smart Port Dual Port Mitsubishi Evo IV to X - Red
TS-0215-1023	Smart Port Dual Port Mitsubishi Evo IV to X - Black

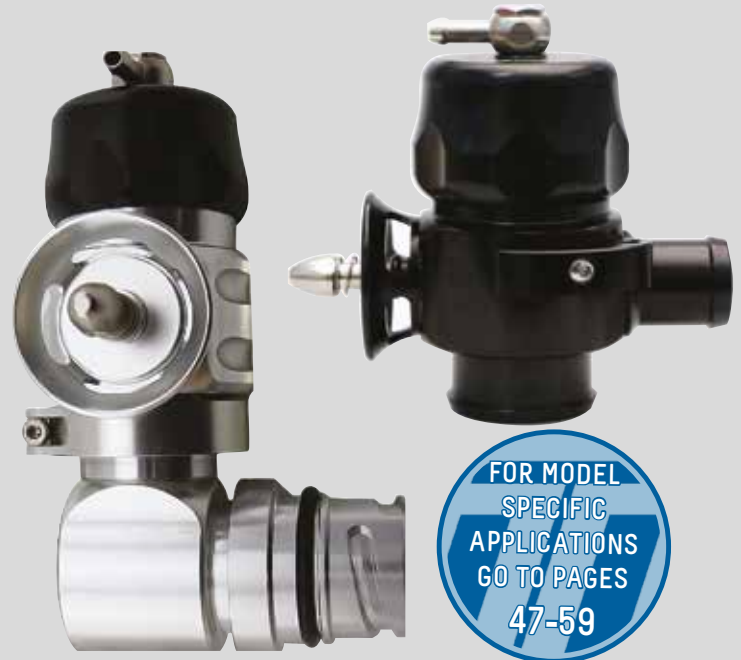

## SUPERSONIC

The quintessential Turbosmart BOV, with that classic Blow-Off Valve noise. The Supersonic vents completely to atmosphere for big sound and big performance. The Supersonic is the BOV for the driver who wants the show along with the go.

- A full-time vent-to-atmosphere BOV, featuring a single trumpet
- Provides the characteristic Turbosmart Blow-Off Valve noise we know and love

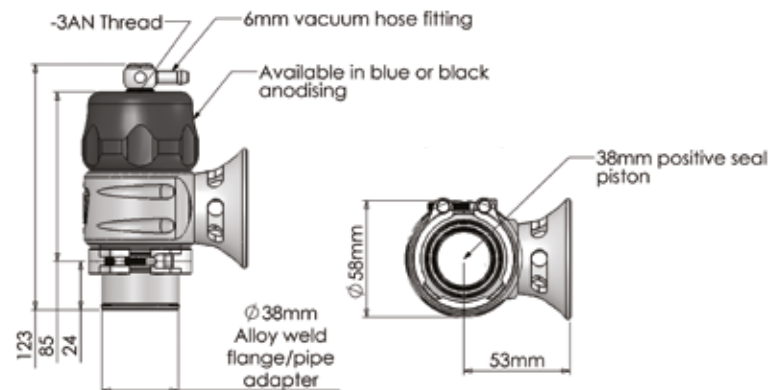

Supersonic Part Numbers	
TS-0205-1300	Blue
TS-0205-1301	Black

For spring charts go to page 12

For spares and accessories go to page 13



## PLUMB BACK

Turbosmart's Plumb Back BOV operates quietly, just like a standard diverter valve, so it does not draw unwanted attention. The Plumb Back offers all the performance and durability benefits of a Turbosmart BOV, but with quiet operation that keeps you under the radar.

- A full time recirculating BOV, with one plumb back port
- Quiet operation

Plumb Back Part Numbers	
TS-0205-1261	32mm Blue
TS-0205-1262	32mm Black
TS-0205-1271	38mm Blue
TS-0205-1272	38mm Black

For spring charts go to page 12

For spares and accessories go to page 13

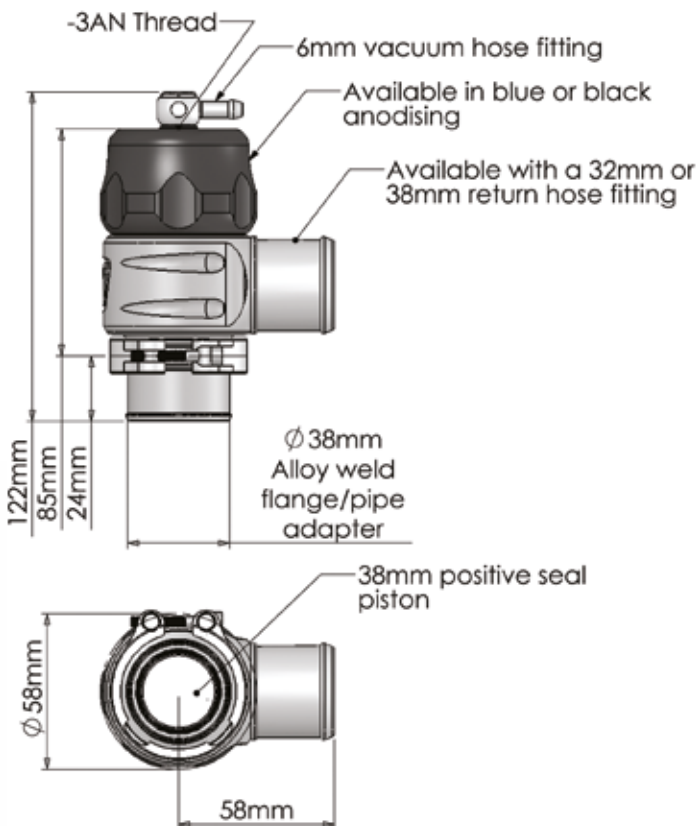

## DUAL PORT

Proof you can have the best of both worlds. The Dual Port is a 50-50 recirculating and vent-to-atmosphere BOV. Offers quiet operation on low boost, avoiding unwanted attention, but vents to atmosphere on high boost for that sought-after Blow-Off Valve sound.

- Features one plumb-back port to route to the vehicle's intake, and one vent-to-atmosphere trumpet
- Quiet operation on low boost, classic Turbosmart BOV noise and full performance on high boost
- Modular design and included spare trumpet and blanking plug allows the valve to be easily transformed into a Supersonic, Plumb Back, or Megasonic\*

Dual Port Part Numbers	
TS-0205-1061	Dual Port Universal 32mm - Blue
TS-0205-1062	Dual Port Universal 32mm - Black
TS-0205-1071	Dual Port Universal 38mm - Blue
TS-0205-1072	Dual Port Universal 38mm - Black

For spring charts go to page 12

For spares and accessories go to page 13



Dual Port Configurations: Supersonic, Plumb Back, Dual Port & Megasonic\* \*With the use of an extra trumpet - sold separately

# BLOW-OFF VALVES

## VEE-PORT PRO

The Vee-Port PRO is an ideal Blow-Off Valve for anyone who is short on space, or looking for a low-weight BOV solution. A full-time vent-to-atmosphere Blow-Off Valve, it features:

- A very compact design, perfect for tight to fit places
- A hard anodized aluminium piston for lightness
- Very high flow ability with a 38mm/1.5in piston
- Precision machining and assembly – the piston and valve body are measured to mere fractions of a millimetre, and perfectly matched to fit each other exactly. Because of this precision, an o-ring is not needed to create a seal
- A wide range of vehicle specific applications.

Vee-Port PRO Part Numbers	
TS-0205-1130	Vee-Port PRO Universal - Blue
TS-0205-1131	Vee-Port PRO Universal - Black

For spring charts go to page 12  
For spares and accessories go to page 13



## BIG BUBBA

Sometimes bigger is just better. Designed for large capacity supercharged and turbocharged engines, including turbo-diesel engines, the Big Bubba is our largest and scariest Blow-Off Valve. Big Bubba features:

- Precision machining and assembly – the piston and valve body are measured to mere fractions of a millimetre, and perfectly matched to fit each other exactly. Because of this precision, an O-ring is not needed to create an effective seal
- Huge 50.8mm/2" inlet and outlet
- Hard anodised aluminium piston for light weight
- Strong V-band mounting system interchangeable with the Race Port

Big Bubba is available in two different styles:

- Bubba Sonic – Full time vent-to-atmosphere
- Big Bubba – Full time recirculating

Big Bubba Part Numbers	
TS-0204-1201	Big Bubba Plumb Back - Blue/Silver
TS-0204-1202	Big Bubba Plumb Back - Black/Silver
TS-0204-1203	Big Bubba Plumb Back - Sleeper (Black/Black)
TS-0204-1301	Bubba Sonic BOV - Blue/Silver
TS-0204-1302	Bubba Sonic BOV - Black/Silver
TS-0204-1303	Bubba Sonic BOV - Sleeper (Black/Black)

For spring charts go to page 12  
For spares and accessories go to page 13



## KOMPACT

Turbosmart's billet construction Kompact range has been designed as a bullet-proof replacement for OEM parts. Our focus on quality design gives the Kompact range a performance edge in boost handling capabilities. They will not leak or burst under pressure. Each Kompact Blow-Off Valve features a tolerance-matched piston and body, which ensures a precise fit between the moving parts, eliminating the need for a body to piston o-ring seal. Thus, providing excellent piston response and reliability over other designs. An o-ring seal is installed at the base of the piston, where it is most needed, to provide a positive seal against boost pressure and remove the possibility of false knock.

### The Kompact range features:

- A stealthy black finish, to blend in with any engine bay
- A range of inlet options including hose fittings, two bolt flange, and the new two and three bolt-flange for turbo compressor cover fitment
- A range of vehicle specific applications including Volkswagen, Audi, Seat, Skoda, EcoBoost, Borg Warner, Subaru, BMW, Mitsubishi, Nissan
- New Applications for Mitsubishi Evo IV to X, Mercedes Benz C63 AMG (W205), Hyundai Veloster Turbo. For more specific information see pages 47-59.

### Kompact Blow-Off Valves are available in two different styles:

- Plumb Back – Full time recirculating
- Dual Port – Half vent-to-atmosphere, half recirculating. The best of both worlds!

Kompact Part Numbers	
TS-0203-1021	Kompact Dual Port - 20mm
TS-0203-1022	Kompact Dual Port - 25mm
TS-0203-1023	Kompact Dual Port - 34mm
TS-0203-1221	Kompact Plumb Back - 20mm
TS-0203-1222	Kompact Plumb Back - 25mm
TS-0203-1223	Kompact Plumb Back - 34mm

For spring charts go to page 12

For spares and accessories go to page 13



# BLOW-OFF VALVES

## BLOW-OFF VALVE CONTROLLER

The Turbosmart Blow-Off Valve Controller is designed for applications such as petrol engines with large cams, heavily ported rotaries, or diesel engines that produce little vacuum and need a helping hand to get the Blow-Off Valve to open.

The Turbosmart Blow-Off Valve Controller is an electronic device which controls the pressure signal to the Blow-Off Valve. It energises a solenoid to release all of the air out of the Blow-Off Valve cap, causing a pressure differential between the piston of the Blow-Off Valve and the cap, which will vent pressure from the intake system. Ideal for diesel engines, the Turbosmart Blow-Off Valve controller is supplied with:

- Wiring loom
- Solenoid and bracket
- Reinforced pressure tubing
- Hose clamps and mounting hardware

**The Turbosmart Blow-Off Valve Controller has some unique features:**

- Uses the vehicles existing throttle position sensor output to determine when to open the BOV
- Has "Sensitivity" and "Duration" settings so the BOV can be tuned to your vehicle and driving style
- Has "Enable" and "Disable" inputs so the BOV can be used as an over boost safety feature, turned off if required or even operated via two switches if a TPS is not available



Blow-Off Valve Controller Kits Part Numbers	
TS-0304-1001	BOV Controller with Blue Race Port BOV
TS-0304-1002	BOV Controller with Black Race Port BOV
TS-0304-1005	BOV Controller with Black Type 5 Supersonic BOV
TS-0304-1006	BOV Controller with Black Kompact Supersonic BOV
TS-0304-1009	BOV Controller with Black Bubba Sonic BOV
TS-0304-1003	BOV Controller and fittings only - No BOV



# BLOW-OFF VALVE SPRING CHARTS



## KOMPACT SPRINGS

Spring Colour	Blue	Green	Pink
Part Number	TS-0203-3001	TS-0203-3003	TS-0203-3002
Free Length	55mm	64mm	72mm
Outside Diameter	23mm	23mm	23mm
Manifold Vacuum - Dual Port (Max)	-13 InHg	-19 InHg	-24 InHg
Manifold Vacuum - Dual Port (Min)	-3 InHg	-9 InHg	-14 InHg
Manifold Vacuum - Plumb Back	-9 InHg	-15 InHg	-20 InHg

## TYPE 5 SPRINGS

Spring Colour	White	Red	Yellow
Part Number	TS-0205-3106	TS-0205-3102	TS-0205-3101
Free Length	108mm	135mm	160mm
Outside Diameter	30mm	29mm	30mm
Manifold Vacuum (Max)	-14 InHg	-17 InHg	-22 InHg
Manifold Vacuum (Min)	-11 InHg	-14 InHg	-20 InHg

## VEE-PORT PRO SPRINGS

Spring Colour	Grey	White
Part Number	TS-0205-3110	TS-0205-3106
Free Length	81mm	108mm
Outside Diameter	29mm	30mm
Manifold Vacuum (Max)	-7 InHg	-21 InHg
Manifold Vacuum (Min)	-6 InHg	-19 InHg



## RACE PORT SPRINGS

		Spring Colour	Pink	Purple	Orange	Green	Blue
		Part Number	TS-0204-2104 (Pink/Purple Spring kit)		TS-0204-2105	TS-0204-3105	TS-0204-3102 (Included in valve)
		Vacuum Pressure	4InHg	10InHg	8InHg	15InHg	18InHg
		Type	Inner	Outer	Inner	Outer	Outer
Manifold Vacuum	0 - 4 InHg		●				
	4 - 8 InHg				●		
	6 - 10 InHg			●			
	10 - 14 InHg		●	●			
	11 - 15 InHg					●	
	14 - 18 InHg						●
	15 - 19 InHg		●			●	
	18 - 22 InHg		●				●
	19 - 23 InHg				●	●	
22 - 26 InHg				●		●	

## BIG BUBBA SPRINGS

		Spring Colour	Purple/Blue	Purple/Green	Purple/Yellow	Purple/Red
		Part Number	TS-0204-2201	TS-0204-2202	TS-0204-2203	TS-0204-2204
		Included in	Sold Separately	Big Bubba BPV	Bubba Sonic BOV	Sold Separately
Manifold Vacuum	0-7 InHg		●			
	8-12 InHg			●		
	13-17 InHg				●	
	18-21 InHg					●

# BLOW-OFF VALVE PARTS AND ACCESSORIES



## KOMPACT BOV PARTS AND ACCESSORIES

Part Number	Description
TS-0203-1101 <b>NEW</b>	Focus RS 2016 2.3L BOV Blanking Plate
TS-0203-1102 <b>NEW</b>	Mustang/Fiesta BOV Blanking Plate
TS-0203-1103 <b>NEW</b>	Mini R56 BOV Blanking Plate
TS-0203-1104 <b>NEW</b>	Clio RS BOV Blanking Plate
TS-0203-1106 <b>NEW</b>	Ford Ecoboost 1.0L BOV Blanking Plate
TS-0203-2002	BOV Kompact Block-off Borg Warner KKK
TS-0203-2067	BOV Ford Mustang 2.3L Ecoboost Plug & MAP Adapter
TS-0203-3001	BOV Kompact Soft Spring-Blue
TS-0203-3002	BOV Kompact Dual Port Spring - Pink
TS-0203-3003	BOV Kompact Plumb Back Spring - Green
TS-0203-3004	BOV Kompact Trumpet Replacement
TS-0203-3005	BOV Kompact 20mm Inlet Fitting
TS-0203-3006	BOV Kompact 25mm Inlet Fitting
TS-0203-3007	BOV Kompact 34mm Inlet Fitting
TS-0203-3008	BOV Kompact 20mm Plumb Back Fitting
TS-0203-3009	BOV Kompact 25mm Plumb Back Fitting
TS-0203-3010	BOV Kompact 34mm Plumb Back Fitting
TS-0203-3011	BOV Kompact Port Blanking Plug
TS-0203-3012	BOV Kompact Shortie Base O-ring Kit
TS-0203-3014	BOV Kompact O-Ring Kit
TS-0205-3011	BOV Uniglide Lubricant 50ml

## TYPE 5 PARTS AND ACCESSORIES

Part Number	Description
TS-0205-2069	BOV Ford F150 2013 - MAP Adapter & Plug
TS-0205-3010	BOV O-Ring System
TS-0205-3101	BOV Spring Yellow DP/SS/VP
TS-0205-3102	BOV Spring Red PB/SC
TS-0205-3103	BOV Port Blanking Plug
TS-0205-3104	BOV 60mm Trumpet Replacement
TS-0205-3105	BOV 50mm Trumpet Replacement
TS-0205-3110	BOV Spring Grey VP Pro S/C
TS-0205-3111	BOV -3AN Banjo Nipple Replacement
TS-0205-3112	BOV Smart Port Upgrade Kit - 50mm Black
TS-0205-3113	BOV Smart Port Upgrade Kit - 50mm Clear
TS-0205-3114	BOV Smart Port Upgrade Kit - 60mm Black
TS-0205-3115	BOV Smart Port Upgrade Kit - 60mm Clear
TS-0205-3200	BOV 25mm Plumb Back fitting
TS-0205-3201	BOV 29mm Plumb Back fitting
TS-0205-3202	BOV 32mm Plumb Back fitting
TS-0205-3203	BOV 34mm Plumb Back fitting
TS-0205-3204	BOV 38mm Plumb Back fitting

## TYPE 5 & VEE PORT PRO MOUNTING ACCESSORIES AND BLANKING PLUGS

Part Number	Description
TS-0205-2002	BOV 38mm Alloy Profiled Adapter
TS-0205-2003	BOV 38mm SS Profiled Adapter
TS-0205-2005	BOV 38mm Alloy Weld Flange
TS-0205-2010	BOV V-Band to 38mm Adapter
TS-0205-2011	BOV V-Band Blanking Plate
TS-0205-2012	BOV 19mm Hose Blanking Plug
TS-0205-2013	BOV 25mm Hose Blanking Plug
TS-0205-2014	BOV 29mm Hose Blanking Plug
TS-0205-2015	BOV 32mm Hose Blanking Plug
TS-0205-2016	BOV 34mm Hose Blanking Plug
TS-0205-2017	BOV 38mm Hose Blanking Plug
TS-0205-2006	BOV 19mm Hose Adapter
TS-0205-2007	BOV 25mm Hose Adapter
TS-0205-2008	BOV 32mm Hose Adapter
TS-0205-2009	BOV 34mm Hose Adapter
TS-0205-2018	BOV 38mm Hose Adapter
TS-0205-2051	BOV Subaru MY99 Adapter System
TS-0205-2052	BOV Nissan R32 Adapter System
TS-0205-2053	BOV Forester GT 2.0L Adapter System
TS-0205-2054	BOV Forester XT 2.5L Adapter System
TS-0205-2055	BOV Mazda/Subaru Flange Adapter
TS-0205-2056	BOV Subaru Flange Adapter System
TS-0205-2057	BOV Nissan Flange Adapter System
TS-0205-2058	BOV Ford XR6 BA-BF adapter kit
TS-0205-2059	BOV Subaru WRX 98 Adapter System
TS-0205-2060	BOV TS-Greddy Flange Adapter
TS-0205-2061	BOV TS-HKS Flange Adapter
TS-0205-3008	BOV 38mm Weld Flange/Hose Adapter Alloy
TS-0205-3009	BOV V-Band clamp assembly
TS-0205-3107	BOV MAZ/SUB Flange Gasket
TS-0205-3108	BOV Subaru Flange Gasket
TS-0205-3109	BOV Nissan Flange gasket
TS-0205-3205	BOV Greddy Adapter Gasket



## RACE PORT PARTS AND ACCESSORIES

Part Number	Description
TS-0204-2001	BOV Race Port Stainless Steel Weld Flange
TS-0204-2004	OLD BOV Race Port Spring System
TS-0204-2005	BOV Race Port to Old 38mm Adapter
TS-0204-2006	BOV Race Port Flange Blank
TS-0204-2104	BOV Race Port Spring System
TS-0204-2105	BOV Race Port 8 inHg Spring - Orange
TS-0204-3001	BOV Race Port Alloy Weld Flange
TS-0204-3002	OLD Race Port Spring 15 InHg
TS-0204-3004	BOV Race Port V-Band
TS-0204-3005	BOV Race Port flange O-Ring
TS-0204-3007	BOV Race Port S/S Weld Flange to Suit Female BOV
TS-0204-3008	BOV Race Port M/S Weld Flange to Suit Female BOV
TS-0204-3010	BOV Race Port Mild Steel Weld Flange Female
TS-0204-3102	BOV Race Port 18 inHg Spring - Blue
TS-0204-3103	BOV Race Port Piston Assembly
TS-0204-3105	BOV Race Port 15 inHg Spring - Green

## POWER PORT PARTS AND ACCESSORIES

Part Number	Description
TS-0207-2001 <b>NEW</b>	BOV Power Port Stainless Steel Weld Flange
TS-0207-3001 <b>NEW</b>	BOV Power Port Alloy Weld Flange
TS-0207-3004 <b>NEW</b>	BOV Power Port V-Band
TS-0207-3007 <b>NEW</b>	BOV Power Port S/S Weld Flange to Suit Female BOV
TS-0207-3008 <b>NEW</b>	BOV Power Port M/S Weld Flange to Suit Female BOV
TS-0207-3010 <b>NEW</b>	BOV Power Port Mild Steel Weld Flange Female

## VEE PORT PRO PARTS AND ACCESSORIES

Part Number	Description
TS-0205-3011	BOV Uniglide Lubricant 50ml
TS-0205-3106	BOV Spring White VP Pro
TS-0205-3110	BOV Spring Grey VP Pro S/C
TS-0205-3111	BOV -3AN Banjo Nipple Replacement

## BIG BUBBA PARTS AND ACCESSORIES

Part Number	Description
TS-0204-2201	BOV Bubba 7 inHg Spring
TS-0204-2202	BOV Bubba 12 inHg Spring
TS-0204-2203	BOV Bubba 17 inHg Spring
TS-0204-2204	BOV Bubba 21 inHg Spring
TS-0205-3011	BOV Uniglide Lubricant 50ml
TS-0204-2205	BOV Bubba 2.0" Inlet Hose Adapter
TS-0204-3201	BOV Bubba 2.0" Plumb Back fitting - Silver
TS-0204-3206	BOV Bubba 2.0" Plumb Back fitting - Black
TS-0204-3202	BOV Bubba 4.0" Trumpet - Silver
TS-0204-3207	BOV Bubba 4.0" Trumpet - Black
TS-0204-3106	BOV Bubba O-Ring Kit
TS-0204-2001	BOV Race Port Stainless Steel Weld Flange
TS-0204-2005	BOV Race Port to Old 38mm Adapter
TS-0204-2006	BOV Race Port Flange Blank
TS-0204-3001	BOV Race Port Alloy Weld Flange
TS-0204-3004	BOV Race Port V-Band
TS-0204-3005	BOV Race Port Flange O-Ring

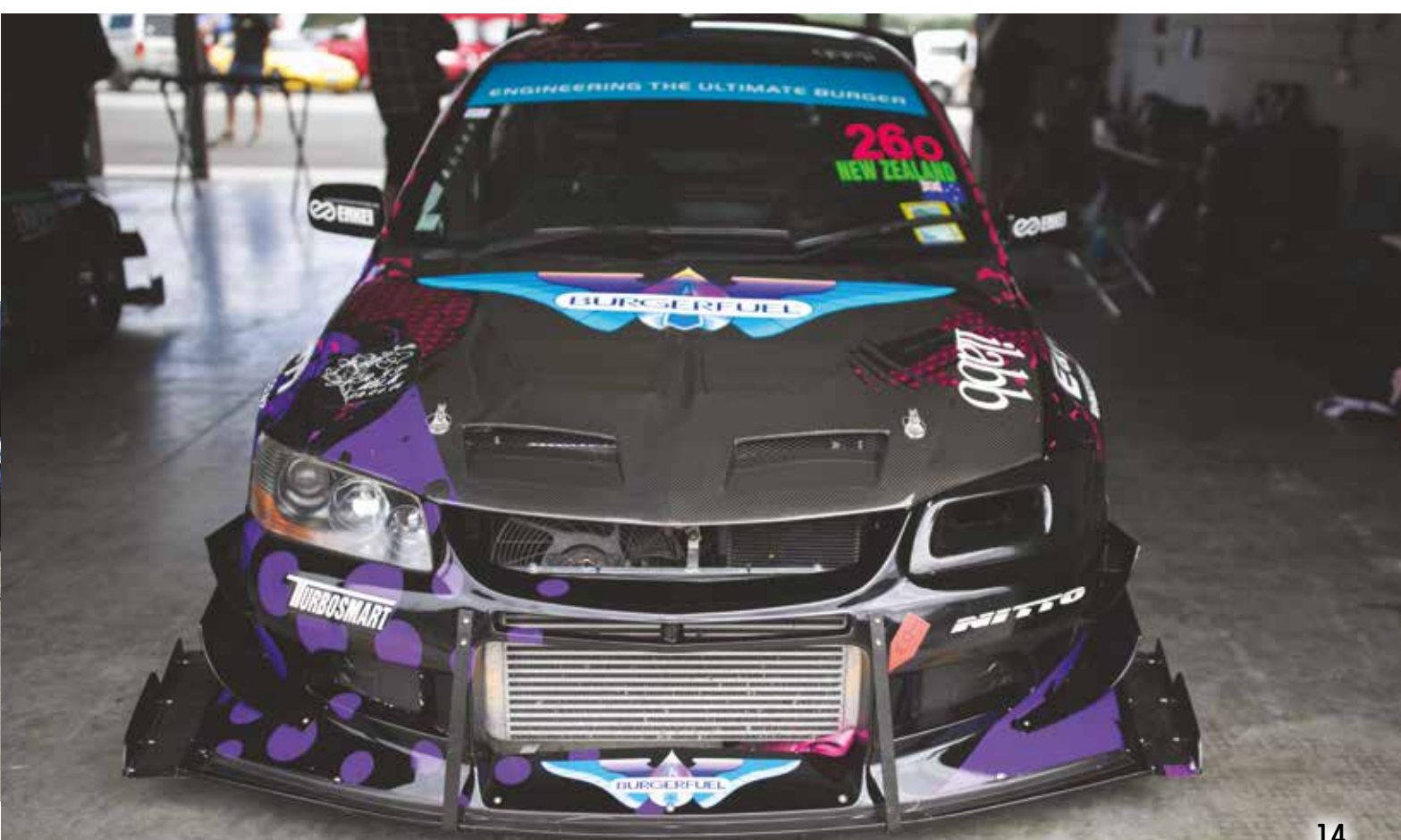

# EXTERNAL WASTEGATES



ULTRA-GATE38  
page 17

COMP-GATE40  
page 18

HYPER-GATE45  
page 19

PRO-GATE50 LITE  
page 20

PRO-GATE50  
page 21

POWER-GATE60  
page 22



## WHAT IS AN EXTERNAL WASTEGATE?

An external wastegate controls boost by bleeding off exhaust gas before it gets to the turbine or rear housing of the turbocharger.

Turbosmart has the largest wastegate range available on the market.

All Turbosmart external wastegates feature:

- Advanced flow technology, making our wastegate range high flowing to suit all applications
- Unrivalled heat handling capacity. Lab tested and race proven.
- A solid, one-piece coated valve
- Advanced silicone Nomex diaphragm



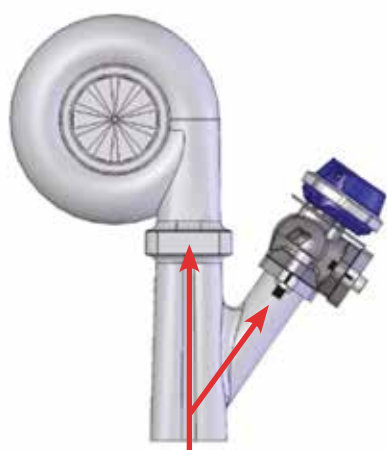

**Best flow – shallow mount angle**

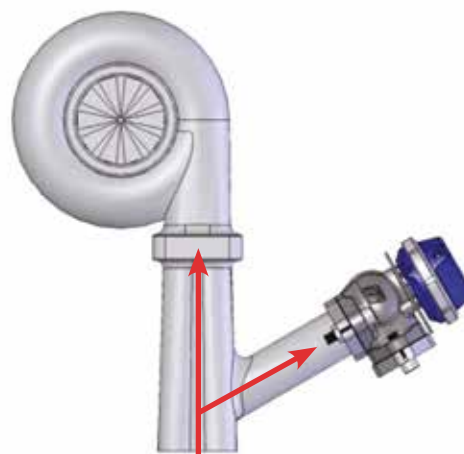

**Good flow – slight mount angle**

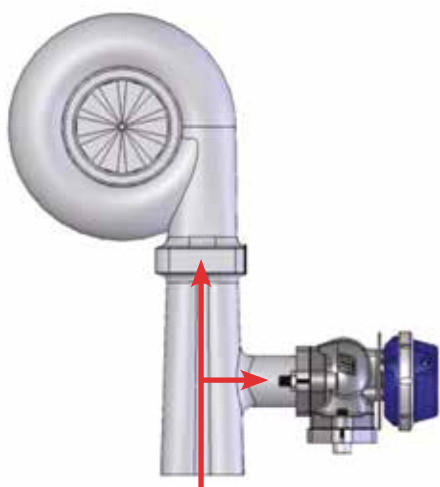

**Poor flow – 90 degree mounting**

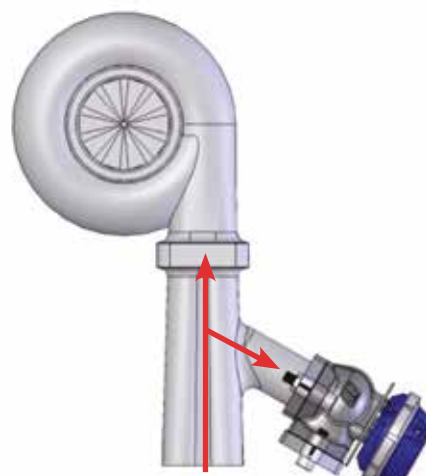

**Not recommended – less than 90 degree mounting**

## WHICH WASTEGATE IS RIGHT FOR MY APPLICATION?

Wastegate choice is dependent on how much, and how quickly exhaust needs to be flowed away from the turbocharger to adequately control boost pressure - while being careful not to flow too much away, slowing boost response.

To determine the size of the wastegate you need, you must first look at engine size and target power. This will allow you to calculate the mass airflow required to produce your target power. This information is used to select the right turbocharger.

Once you know how much mass flow the engine puts out and how much mass flow the turbine requires, you'll then be able to determine how much mass flow the wastegate needs to bypass to keep the turbine running in its optimum range.

As you can see, this throws up an infinite number of variables related to wastegate sizing. All applications differ slightly, so it is best to speak with an experienced engine builder or tuner for advice on what's been tried and tested.

If you are tossing up between two wastegate sizes, it's always better to go larger as this gives you more ability to control boost with future modifications and it will give the wastegate better heat handling capabilities.

## WHERE SHOULD I MOUNT MY WASTEGATE?

The mounting position of your wastegate is largely determined by your turbo and manifold setup and may be constrained by space restrictions in your engine bay.

The following points should be considered when mounting your wastegate:

1. The weld flanges should be welded to your exhaust system.
2. The weld flanges should be compatible with Stainless Steel and Mild steel welding rod material.
3. Secure the wastegate to the weld flanges with the supplied V-Band clamps. Do not forget to put the valve seat into the body before mounting the unit on the exhaust manifold. Tighten the supplied M6 screws to a torque value of 14 Nm (10 ft/lbs)
4. For best results an attempt should be made, if space allows, to mount your wastegate at a shallow angle in line with exhaust flow. See the schematic diagrams above for examples of mounting positions.
5. Wastegates should be mounted within adequate airflow to provide cooling.

# EXTERNAL WASTEGATES



## ULTRA-GATE38

The smallest wastegate in the Turbosmart line up, the Ultra-Gate38 includes high-end features and build quality at an entry-level price. The Ultra-Gate38 features:

- 38mm valve size
- Popular 2-bolt flange fitting to suit 1 5/8" OD pipe
- Locking collar for compact size and easy spring changes
- Available in HP (high pressure) configuration

Supplied with: Valve seat, gaskets, 2 x 1/16 NPT vacuum fittings, blanking plugs, and collar tool

Ultra-Gate38 Part Numbers	
TS-0501-1101	Ultra-Gate38 7PSI - Blue
TS-0501-1102	Ultra-Gate38 7PSI - Black
TS-0501-1140	Ultra-Gate38 14PSI - Blue
TS-0501-1141	Ultra-Gate38 14PSI - Black

HP Upgrade available go to page 23 for more information

For spares and accessories go to page 38

For spring charts go to page 31

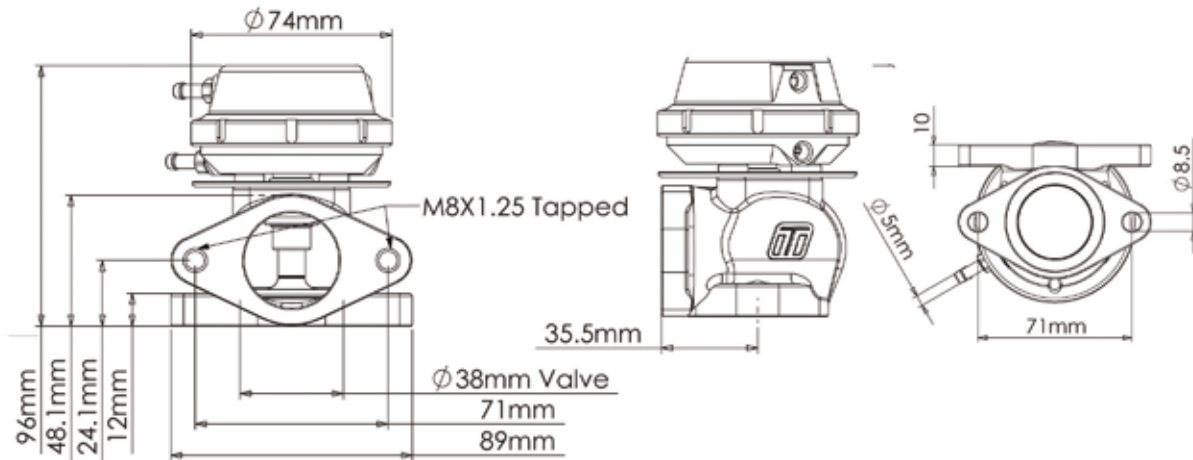



## COMP-GATE40

The Comp-Gate40 gives you maximum performance in minimal space. The Comp-Gate40 features:

- 40mm valve size
- Vee-band clamp mounting system to suit 1 3/4" OD pipe
- Locking collar for compact size and easy spring changes
- Available in HP (high pressure) configuration

Supplied with: Inlet and outlet weld flanges, vee-band clamps, valve seat, 2 x 1/16 NPT vacuum fittings, blanking plugs, and collar tool

Comp-Gate40 Part Numbers	
TS-0505-1003	Comp-Gate40 5 psi - Blue
TS-0505-1004	Comp-Gate40 5 psi - Black
TS-0505-1005	Comp-Gate40 7PSI - Blue
TS-0505-1006	Comp-Gate40 7PSI - Black
TS-0505-1009	Comp-Gate40 14PSI - Blue
TS-0505-1010	Comp-Gate40 14PSI - Black

HP Upgrade available go to page 23 for more information  
For spares and accessories go to page 38  
For spring charts go to page 31

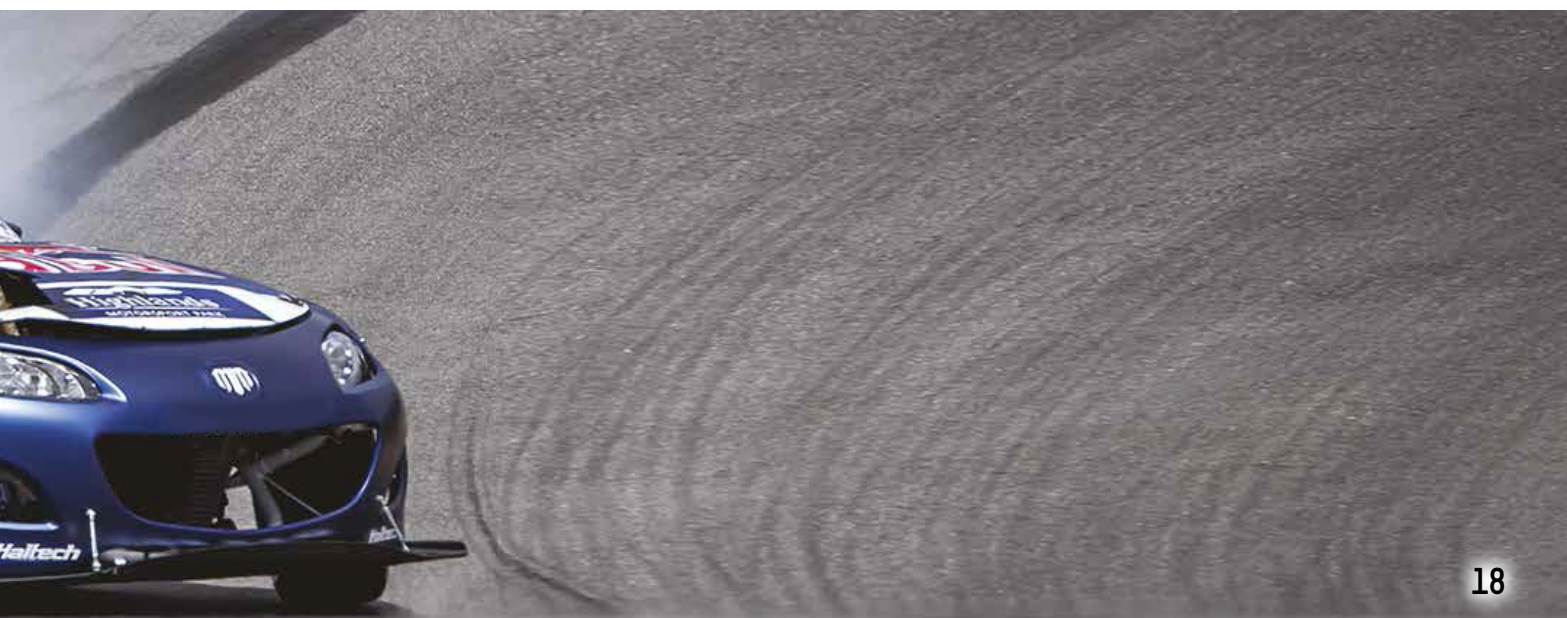
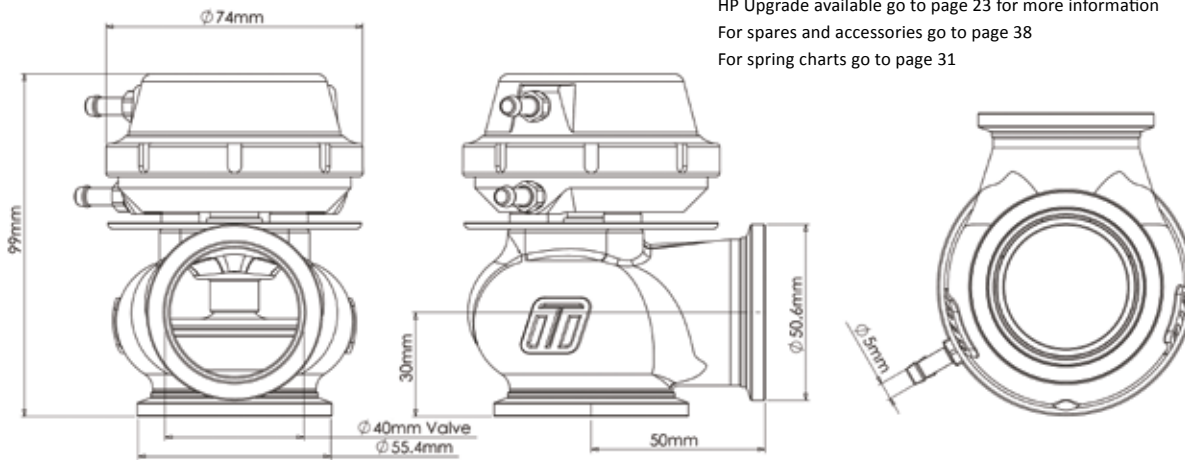

# EXTERNAL WASTEGATES



## HYPER-GATE45

The Hyper-Gate45 offers class-leading flow path and temperature resistance in a compact and lightweight package. The Hyper-Gate45 features:

- 45mm valve size
- Vee-band clamp mounting system to suit 1 7/8" OD pipe
- Locking collar for compact size and easy spring changes
- Available in HP (high pressure) configuration

Supplied with: Inlet and outlet weld flanges, vee-band clamps, valve seat, 2 x 1/16 NPT vacuum fittings, blanking plugs, and collar tool

Hyper-Gate45 Part Numbers	
TS-0506-1001	Hyper-Gate45 7PSI - Blue
TS-0506-1002	Hyper-Gate45 7PSI - Black
TS-0506-1040	Hyper-Gate45 14PSI - Blue
TS-0506-1041	Hyper-Gate45 14PSI - Black

HP Upgrade available go to page 23 for more information  
 For spring charts go to page 25  
 For spares and accessories go to page 27

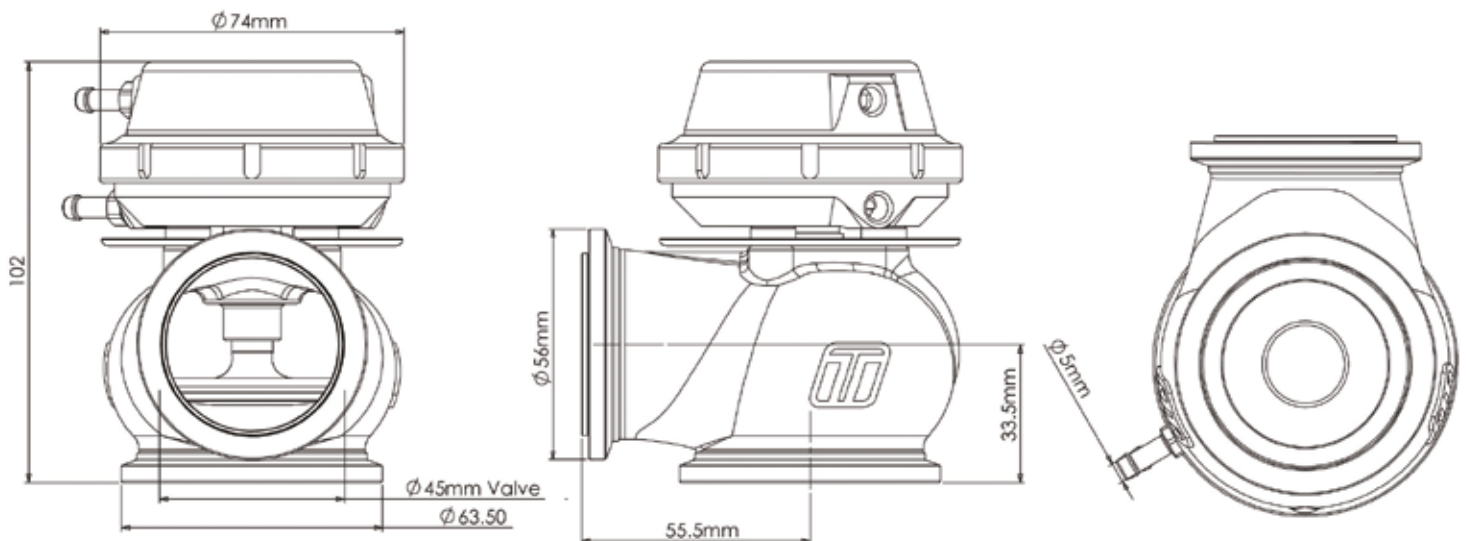



## PRO-GATE50 LITE

Turbosmart's innovative new Pro-Gate50 Lite combines the 50mm valve size of our high-flowing Pro-Gate with a compact cap design, for when the higher flow capability of a larger wastegate is required, but space is at a premium.

The Pro-Gate50 Lite takes up less engine bay real estate than similar flowing wastegates, so it's perfect for aftermarket turbo kit applications with high flow needs, but limited space for turbo components in the engine bay.

The Pro-Gate50 Lite features:

- 50mm valve size
- Vee-band clamp mounting system to suit 2" OD pipe
- HP Upgrade Available

Supplied with: Inlet and outlet weld flanges, vee-band clamps, valve seat, and 2 x 1/16 NPT vacuum fittings

Pro-Gate50 Lite Part Numbers	
TS-0502-1201	WG50 Pro-Gate50-Lite 7psi Blue
TS-0502-1202	WG50 Pro-Gate50-Lite 7PSI - Black
TS-0502-1240	WG50 Pro-Gate50-Lite 14psi Blue
TS-0502-1241	WG50 Pro-Gate50-Lite 14PSI - Black

HP Upgrade available go to page 17 for more information

For spring charts go to page 25

For spares and accessories go to page 27

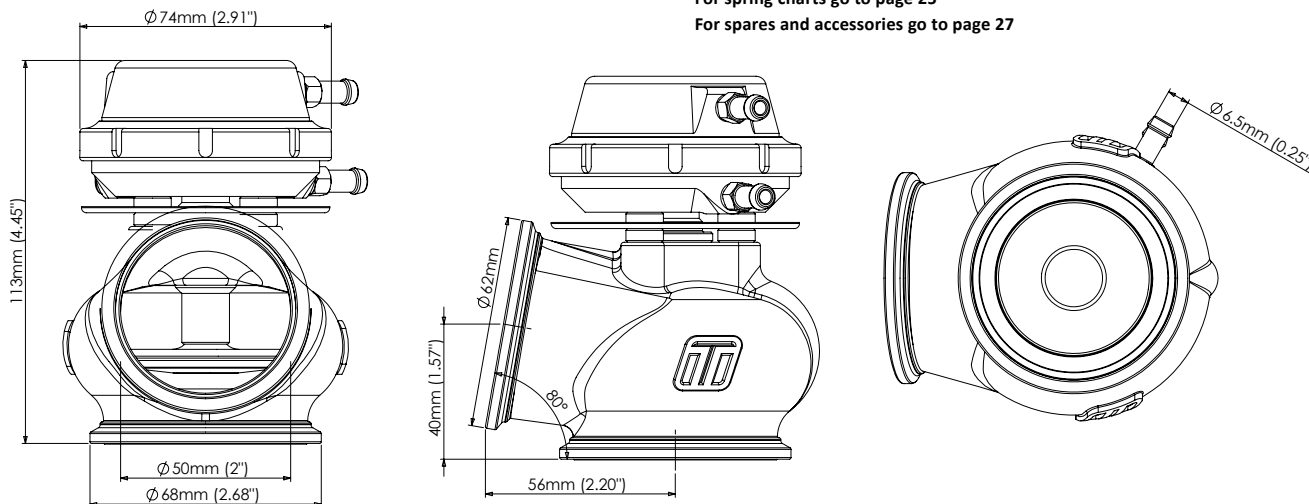

# EXTERNAL WASTEGATES

## PRO-GATE50

A compact body, superior flow path and high temperature resistance makes the Pro-Gate50 a market leader in its sector. Suitable for high performance turbocharged engines with an external wastegate turbocharger system, the Pro-Gate50 features:

- 50mm valve size
- Vee-band clamp mounting system to suit 2" OD pipe

Supplied with: Inlet and outlet weld flanges, vee-band clamps, valve seat, and 2 x 1/8 NPT vacuum fittings

Pro-Gate50 Part Numbers	
TS-0502-1001	Pro-Gate50 7PSI - Blue
TS-0502-1002	Pro-Gate50 7PSI - Black
TS-0502-1040	Pro-Gate50 14PSI - Blue
TS-0502-1041	Pro-Gate50 14PSI - Black

For spring charts go to page 25

For spares and accessories go to page 27

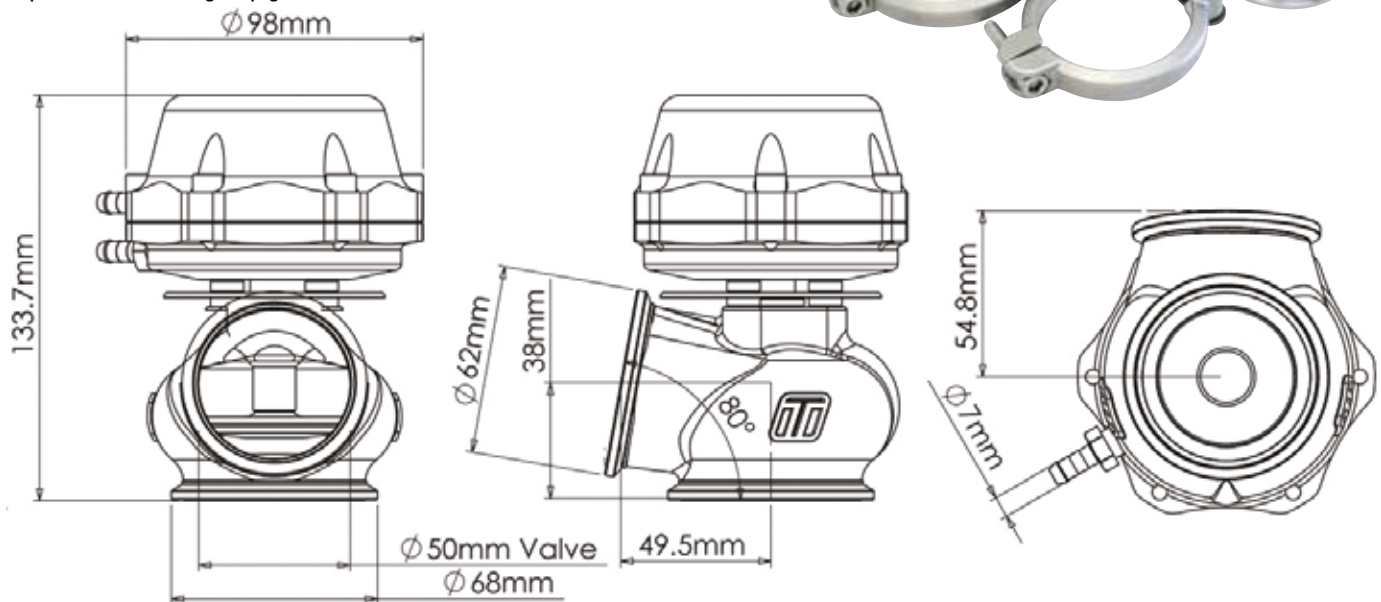

# POWER-GATE60

The largest wastegate in our range, the Power-Gate60. Suitable for high performance turbocharged engines with an external wastegate turbocharger system, the Power-Gate60 features:

- 60mm valve size
- Vee-band clamp mounting system to suit 2 1/2" OD pipe

Supplied with: Inlet and outlet weld flanges, vee-band clamps, valve seat, and 2 x 1/8 NPT vacuum fittings



Power-Gate60 Part Numbers	
TS-0503-1001	Power-Gate60 7PSI - Blue
TS-0503-1002	Power-Gate60 7PSI - Black
TS-0503-1040	Power-Gate60 14PSI - Blue
TS-0503-1041	Power-Gate60 14PSI - Black

For spring charts go to page 25

For spares and accessories go to page 27

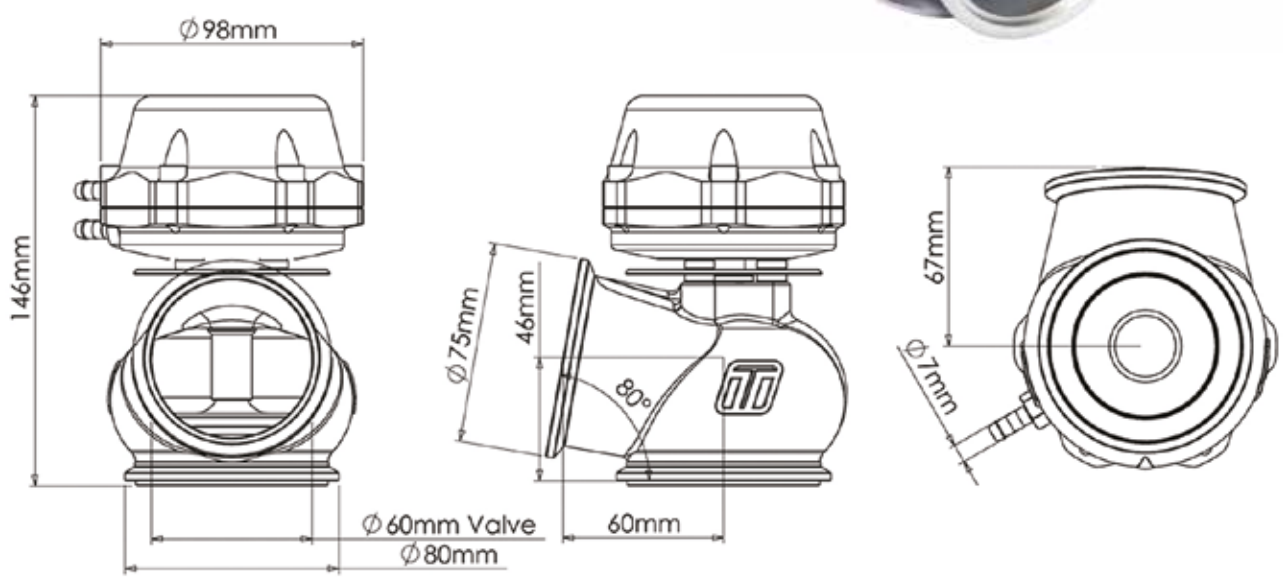

# SENSOR CAPS

With the Turbosmart wastegate sensor cap you can "see" into the wastegate. You can log the wastegate valve position and know exactly what it is doing in relation to other engine operating conditions.

For example, you can log data to see how much wastegate valve lift you have through the rev range, and how that corresponds to boost levels. No uncertainty, just hard data.

The Turbosmart Wastegate Sensor Cap:

- Is the first of its kind on the market
- Allows the user to install a valve position sensor to their standard Turbosmart wastegate by only changing the cap.
- Is compatible with a wide range of popular data loggers (MoTec, RacePak, AIM, etc.)
- Utilises a simple 0-5 volt sensor found in many auto parts stores (or available directly from Turbosmart)
- Is an off the shelf item, available for all current Turbosmart wastegate sizes: 38mm, 40mm, 45mm, 50mm, and 60mm

Sensor Cars Part Numbers	
TS-0502-3010	WG50/60 Sensor Cap - Blue
TS-0502-3011	WG50/60 Sensor Cap - Black
TS-0505-3014	WG38/40/45/50L Sensor Cap - Blue
TS-0505-3015	WG38/40/45/50L Sensor Cap - Black
TS-0502-2008	Sensor
TS-0502-2009	Sensor plug



# EXTERNAL WASTEGATES

## HP WASTEGATES

The world's highest pressure external wastegates – Turbosmart's HP wastegate range retains the compactness of and lightness Turbosmart wastegates are known for, with the added bonus of being capable of handling high boost pressures.

The HP wastegates are:

- Available in 38mm, 40mm, and 45mm sizes
- 35PSI standard, 40PSI optional
- Only 28mm taller than standard wastegates
- Ideal for turbo diesel and drag racing

HP Wastegates Part Numbers	
TS-0501-1201	Ultra-Gate38 HP 35PSI - Blue
TS-0501-1202	Ultra-Gate38 HP - 35PSI - Black
TS-0505-1201	Comp-Gate40 HP 35PSI - Blue
TS-0505-1202	Comp-Gate40 HP 35PSI - Black
TS-0506-1201	Hyper-Gate45 HP 35PSI - Blue
TS-0506-1202	Hyper-Gate45 HP 35PSI - Black
TS-0502-1301	Pro-Gate50 Lite 35PSI - Blue
TS-0502-1302	Pro-Gate50 Lite 35PSI - Black
TS-0505-2010	Blue HP 35PSI Upgrade kit suits 38mm, 40mm, 45mm, 50mmL
TS-0505-2011	Black HP 35PSI Upgrade kit suits 38mm, 40mm, 45mm, 50mmL

For spring charts go to page 25

For spares and accessories go to page 27

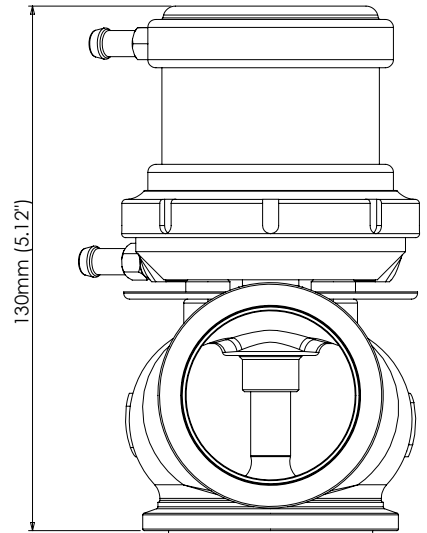
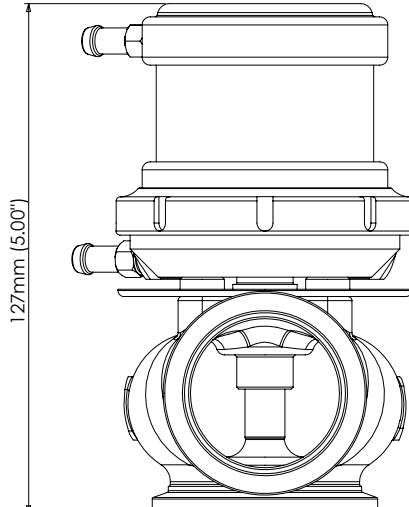
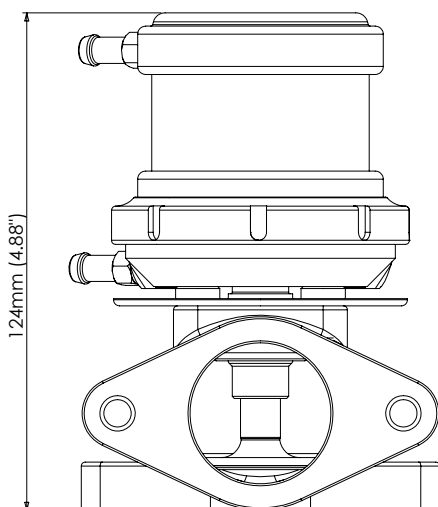



# INTERNAL WASTEGATE ACTUATORS

## WHAT IS AN INTERNAL WASTEGATE ACTUATOR?

On an internally wastegated turbo, the wastegate valve is built into the turbine housing. The wastegate valve is controlled by an internal wastegate actuator. As boost rises the actuator controls the position of the wastegate valve, which in turn controls the exhaust gas flow to the turbine.

The Turbosmart wastegate actuator range has been designed as a stronger, more reliable replacement for OEM parts. Like all Turbosmart parts, billet construction means they are stronger and more durable than a stock actuator, while Turbosmart's focus on performance means boost comes on faster and holds on longer, putting you in control!

The Turbosmart IWG-75 actuator range features:

- Base spring pressure available from 3PSI to 26PSI
- Stable boost control
- Improved boost response
- Flatter boost curve in the top end
- A range of vehicle/turbo specific applications



Internal Wastegate Actuator Part Numbers	
TS-0681-5072 IWG75	Universal 150mm Actuator 7PSI
TS-0681-5102 IWG75	Universal 150mm Actuator 10PSI
TS-0681-5142 IWG75	Universal 150mm Actuator 14PSI
TS-0625-1072 IWG75	Garrett GT2860RS (Disco Potato) 7PSI
TS-0625-4072 IWG75	IWG75 Garrett GTX28R SR20 7PSI
TS-0620-1142 IWG75	Borg Warner EFR B1 Single Scroll 14PSI
TS-0620-3142 IWG75	Borg Warner EFR B2 Single/Twin Scroll 14PSI
TS-0620-2142 IWG75	Borg Warner EFR B1 Twin Scroll 14PSI
TS-0620-2263 IWG75	Borg Warner B1 Twin Scroll 26 PSI

For spring charts go to page 25  
For spares and accessories go to page 27



## TWIN PORT ACTUATOR NEW

The Twin Port IWG-75 uses the air-pressure differential between two sealed chambers to create a dynamic force which overcomes the mechanical spring force in the actuator. Its benefits include:

- More precise boost curve and wider range between minimum and maximum boost compared to conventional single-port actuators
- Ideal for traction-limited applications where precise control is important, such as front-wheel-drive or drag racing vehicles
- Billet construction for greater durability and strength than a stock wastegate actuator
- Improved response means boost comes on faster and holds longer, with less drop off at high RPM
- Interchangeable springs for a huge range of boost levels

Twin Port Actuator Part Numbers	
TS-0681-6142 IWG75	Twin Port Universal Actuator 14PSI
TS-0620-3143 IWG75	Twin Port Borg Warner EFR B2 Single/Twin Scroll 14PSI
TS-0620-1143 IWG75	Twin Port Borg Warner EFR B1 Single Scroll 14PSI
TS-0620-2143 IWG75	Twin Port Borg Warner EFR B1 Twin Scroll 14PSI

For spring charts go to page 25  
For spares and accessories go to page 27



## HIGH PRESSURE INTERNAL WASTEGATE ACTUATOR

Turbosmart's Internal Wastegate Actuators are quickly becoming one of the hottest boost-control products on the market. And for those wanting to run big boost pressure, without the hassle of fitting custom exhaust manifolds and external wastegates, Turbosmart introduces the IWGHP, High Pressure Internal Wastegate Actuator. The IWGHP range provides better turbo response and greater sensitivity when managing boost than a stock actuator, with the added bonus of being capable of handling high boost pressures. Only 28mm longer than the standard IWG75 these wastegates are ideal for high boost turbo diesel and racing applications.

Available with 35PSI springs as standard, Turbosmart also offers up to 40PSI springs, for the extra hard core. Yep, that's 40PSI without even having to change your manifold.

High Pressure Internal Wastegate Actuator Part Numbers	
TS-0626-1354	Universal High Pressure Actuator 35 PSI

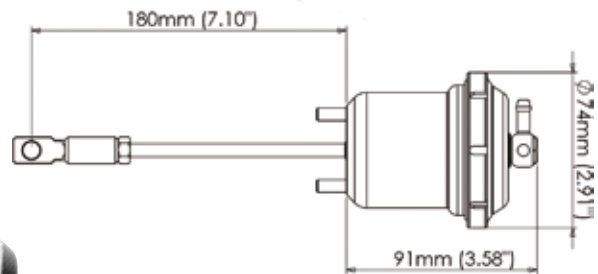

# WASTEGATE SPRING CHARTS



## WASTEGATE SPRING CHARTS

INTERNAL WASTEGATE ACTUATOR SPRINGS, ULTRA-GATE38 SPRINGS,  
COMP-GATE40 SPRINGS, HYPER-GATE45 SPRINGS & PRO-GATE50 LITE SPRINGS

Spring Colour	Brown/Black	Brown/Grey	Brown/Purple	Brown/Red	Brown/Blue	Brown/Pink
Part Number	TS-0505-2001	TS-0505-2002	TS-0505-2003	TS-0505-2004	TS-0505-2005	TS-0505-2006
Free Length	32mm	36mm	43mm	52mm	68mm	60mm
Outside Diameter	29mm	29mm	36.5mm	36.5mm	44mm	44mm
Spring Pressure	3PSI	5PSI	7PSI	11PSI	10PSI	7PSI
Spring Location	Inner	Inner	Middle	Middle	Outer	Outer

	PSI	BAR	Kpa						
	3	0.207	20.68	●					
5	0.345	34.47		●					
7	0.483	48.26				●			
10	0.69	68.95						●	
11	0.76	75.84					●		
12	0.827	82.74			●	●			
13	0.89	89.6	●					●	
14	0.965	96.53				●			●
15	1.03	103.4			●			●	
16	1.1	110			●		●		
17	1.172	117.2				●		●	
18	1.241	124.1					●		●
19	1.31	131			●	●			●
20	1.38	138	●			●		●	
21	1.45	145					●	●	
22	1.517	151.7			●	●		●	
23	1.59	159			●		●		●
24	1.655	165.5	●				●	●	
26	1.793	179.3			●		●	●	



BLOW-OFF VALVES  
WASTEGATES  
BOOST CONTROLLERS  
FUEL CUT DEFENDERS  
GAUGES/BRAS  
FUEL PRESSURE REGULATORS  
FUEL RAIL ADAPTERS  
FUEL FILTERS/OPRS  
SILICONE HOSE  
PRODUCT FITMENT GUIDE

## PRO-GATE50 SPRINGS & POWER-GATE60 SPRINGS

Spring Colour	Black/Pink	Black/Grey	Black/White	Black/Blue	Black/Yellow	Black/Purple	Black/Red
Part Number	TS-0502-2007	TS-0502-2001	TS-0502-2002	TS-0502-2004	TS-0502-2005	TS-0502-2003	TS-0502-2006
Free Length	62mm	75mm	93mm	90mm	113mm	85mm	121mm
Outside Diameter	36.5mm	36.5mm	36.5mm	49mm	49mm	59mm	59mm
Spring Pressure	3PSI	5PSI	7PSI	10PSI	14PSI	7PSI	12PSI
Spring Location	Inner	Inner	Inner	Middle	Middle	Outer	Outer

Desired Boost Pressure	PSI	BAR	Kpa							
	3	0.207	20.68	●						
	5	0.345	34.47		●					
	7	0.483	48.26			●				
	10	0.69	68.95				●			
	12	0.827	82.74						●	
	13	0.89	89.6	●			●			
	14	0.965	96.53					●		
	15	1.03	103.4		●		●			
	17	1.172	117.2		●					●
	19	1.31	131		●			●		
	20	1.38	138	●			●		●	
	21	1.488	144.8					●	●	
	22	1.517	151.7					●		●
	24	1.655	165.5	●				●	●	
	25	1.72	172.37	●				●		●
26	1.793	179.3		●			●	●		
28	1.931	193.1				●		●		
29	1.999	199.9				●	●		●	
31	2.137	213.7		●			●		●	
33	2.275	227.5				●		●	●	

## HP GATE SPRINGS

Spring Colour	Brown/Orange	Brown/Green	Brown/Red
Part Number	TS-0505-2012	TS-0505-2013	TS-0505-2014
Free Length	82mm	135mm	130mm
Outside Diameter	30mm	44mm	41mm
Spring Pressure	10PSI	25PSI	30PSI
Spring Location	Inner	Outer	Outer

Desired Boost Pressure	PSI	BAR	Kpa			
	10	0.69	68.95	●		
	25	1.72	172		●	
	30	2.07	207			●
	35	2.4	241	●	●	
	40	2.76	276	●		●



# WASTEGATE PARTS AND ACCESSORIES

## ULTRA-GATE38 PARTS AND ACCESSORIES, COMP-GATE40 PARTS AND ACCESSORIES, HYPER-GATE45 PARTS AND ACCESSORIES, PRO-GATE50 LITE PARTS AND ACCESSORIES

Part Number	Description
<b>Springs</b>	
TS-0505-2001	WG38/40/45/50L 3PSI IN SPG-BN/BK
TS-0505-2002	WG38/40/45/50L 5PSI IN SPG-BRN/GRY
TS-0505-2003	WG38/40/45/50L 7PSI MID SPG-BN/PUR
TS-0505-2004	WG38/40/45/50L 11PSI MID SPG-BN/RD
TS-0505-2005	WG38/40/45/50L 10PSI OUT SPG-BN/BL
TS-0505-2006	WG38/40/45/50L 7PSI OUT SPRG-BN/PK
<b>Nipples and Hose Fittings</b>	
TS-0505-2007	1/16NPT Male-1/8NPT Female Fit
TS-0505-2008	1/16NPT Male - -3AN Flare Fit
TS-0505-2009	1/16NPT Male - -4AN Flare fit
TS-0505-3009	1/16NPT 6mm Hose Tail Fittings + Blanks
<b>HP Conversion Kits</b>	
TS-0505-2010	WG 35 PSI Conversion Kit Blue
TS-0505-2011	WG 35 PSI Conversion Kit Black
TS-0505-2012	WG38/40/45/50L HP 10PSI Inner Spring Brown/Orange
TS-0505-2013	WG38/40/45/50L HP 25 PSI Outer Spring Brown/Green
TS-0505-2014	WG38/40/45/50L HP 30 PSI Outer Spring Brown/Red
TS-0505-3006	WG38/40/45/50L Diaphragm Assembly
<b>Locking collars and tools</b>	
TS-0505-3007	74mm Locking Collar
TS-0505-3008	74mm Collar Tool
<b>Replacement caps</b>	
TS-0501-3005	WG38 Top Cap replacement - Blue
TS-0501-3006	WG38 Top Cap replacement - Black
TS-0504-3012	WG45 Top Cap replacement - Blue
TS-0504-3013	WG45 Top Cap replacement - Black
TS-0505-3012	WG38/40/45/50L Top Cap replacement - Blue
TS-0505-3013	WG38/40/45/50L Top Cap replacement - Black
TS-0505-3014	WG38/40/45/50L Top Sensor Cap - Blue
TS-0505-3015	WG38/40/45/50L Top Sensor Cap - Black
TS-0502-2008	Wastegate Valve Position Sensor
TS-0502-2009	Wastegate Valve Position Sensor Plug

## ULTRA-GATE38 MOUNTING ACCESSORIES

Part Number	Description
TS-0501-2001	WG38 Weld Flanges - Stainless
TS-0501-2002	WG38 Weld Flanges - Mild Steel
TS-0501-3002	WG38 Manifold Gasket-SS 2-Pack
TS-0501-3103	WG38 UltraGate Valve Seat



## COMP-GATE40 MOUNTING ACCESSORIES

Part Number	Description
TS-0505-3001	WG40 Inlet Weld Flange
TS-0505-3002	WG40 Outlet Weld Flange
TS-0505-3003	WG40 Valve Seat
TS-0505-3004	WG40 Inlet V-Band
TS-0505-3005	WG40 Outlet V-Band

## HYPER-GATE45 MOUNTING ACCESSORIES

Part Number	Description
TS-0504-3001	WG45 Inlet Weld Flange
TS-0504-3002	WG45 Outlet Weld Flange
TS-0504-3003	WG45 Valve Seat
TS-0504-3004	WG45 Inlet Vee Band
TS-0504-3005	WG45 Outlet Vee Band
TS-0504-3007	WG45 ALLOY Inlet Weld Flange
TS-0504-3008	WG45 ALLOY Outlet Weld Flange

## PRO-GATE50/PRO-GATE50 LITE MOUNTING ACCESSORIES

Part Number	Description
TS-0502-3001	WG50 Inlet Weld Flange
TS-0502-3002	WG50 Outlet Weld Flange
TS-0502-3003	WG50 Valve Seat
TS-0502-3004	WG50 Inlet V-Band
TS-0502-3005	WG50 Outlet V-Band
TS-0502-3007	WG50 Alloy Inlet Weld Flange
TS-0502-3008	WG50 Alloy Outlet weld flange

## PRO-GATE50 / POWER-GATE60 PARTS AND ACCESSORIES

Part Number	Description
<b>Springs</b>	
TS-0502-2001	WG50/60 5PSI IN SPRG-BLK/GRY
TS-0502-2002	WG50/60 7PSI IN SPRG-BLK/WHT
TS-0502-2003	WG50/60 7PSI OUT SPRG-BLK/PUR
TS-0502-2004	WG50/60 10PSI MID SPRG-BLK/BLU
TS-0502-2005	WG50/60 14PSI MID SPRG-BLK/YEL
TS-0502-2006	WG50/60 12PSI OUT SPRG-BLK/RED
TS-0502-2007	WG50/60 3PSI IN SPRG-BLK/PNK
<b>Nipples and Hose Applications</b>	
TS-0502-3009	WG50/60 1/8NPT - 6mm Hose Tail Fittings & Blanks
<b>Replacement caps</b>	
TS-0502-3010	WG50/60 Sensor Cap replacement - Cap Only - Blue
TS-0502-3011	WG50/60 Sensor Cap replacement - Cap Only - Black
TS-0502-3014	WG60 Top Cap replacement - Blue
TS-0502-3015	WG60 Top Cap replacement - Black
TS-0502-2008	Wastegate Valve Position Sensor
TS-0502-2009	Wastegate Valve Position Sensor Plug
TS-0503-3009	WG60 Top Cap replacement - Blue
TS-0503-3010	WG60 Top Cap replacement - Black

### POWER-GATE60 MOUNTING ACCESSORIES

Part Number	Description
TS-0503-3001	WG60 Inlet Weld Flange
TS-0503-3002	WG60 Outlet Weld Flange
TS-0503-3003	WG60 Valve Seat
TS-0503-3004	WG60 Inlet V-Band
TS-0503-3005	WG60 Outlet V-Band
TS-0503-3007	WG60 Alloy Inlet Weld Flange
TS-0503-3008	WG60 Alloy Outlet Weld flange

### INTERNAL WASTEGATE PARTS AND ACCESSORIES

Part Number	Description
TS-0600-2001	IWG75 Diaphragm Replacement
TS-0600-2002	IWG75 EVO Hood Kit
TS-0600-2003	IWG75 TP Diaphragm Assembly Replacement
TS-0600-3001	IWG75 6.3mm (0.25") Clevis
TS-0600-3002	IWG75 8.2mm (0.32") Clevis
TS-0600-3003	IWG75 Clevis with 8mm Pin
TS-0505-2001	WG38/40/45 3PSI IN SPG-BN/BK
TS-0505-2002	WG38/40/45 5PSI IN SPG-BRN/GRY
TS-0505-2003	WG38/40/45 7PSI MID SPG-BN/PUR
TS-0505-2004	WG38/40/45 11PSI MID SPG-BN/RD
TS-0505-2005	WG38/40/45 10PSI OUT SPG-BN/BL
TS-0505-2006	WG38/40/45 7PSI OUT SPRG-BN/PK



### BORG WARNER EFR SERIES TURBO ACCESSORY FITMENT GUIDE

EFR Turbo Series	Borg Warner		Turbosmart Actuator (WG)		Turbosmart Bypass Valve		
	Part Number	Description	Single Port	Twin Port	Recirculating	Dual Port	Block Off Plate
EFR-6258 B1	179150	Single Scroll - 0.64 A/R	TS-0620-1142	TS-0620-1143	TS-0203-1261	TS-0203-1061	TS-0203-2002
	179388	Single Scroll - 0.64 A/R	TS-0620-1142	TS-0620-1143	TS-0203-1261	TS-0203-1061	TS-0203-2002
	11589880036	Twin Scroll - 0.80 A/R	TS-0620-2142	TS-0620-2143	TS-0203-1261	TS-0203-1061	TS-0203-2002
EFR-6758 B1	1159880034	Single Scroll - 0.85 A/R	TS-0620-1142	TS-0620-1143	TS-0203-1261	TS-0203-1061	TS-0203-2002
	11589880035	Single Scroll - 0.85 A/R	TS-0620-1142	TS-0620-1143	TS-0203-1261	TS-0203-1061	TS-0203-2002
	11589880037	Twin Scroll - 0.80 A/R	TS-0620-2142	TS-0620-2143	TS-0203-1261	TS-0203-1061	TS-0203-2002
EFR-7163 B1	11639880005	Single Scroll - 0.85 A/R	TS-0620-1142	TS-0620-1143	TS-0203-1261	TS-0203-1061	TS-0203-2002
	11639880006	Single Scroll - 0.85 A/R	TS-0620-1142	TS-0620-1143	TS-0203-1261	TS-0203-1061	TS-0203-2002
	11639880002	Twin Scroll - 0.80 A/R	TS-0620-2142	TS-0620-2143	TS-0203-1261	TS-0203-1061	TS-0203-2002
EFR-7064 B2	179355	Single Scroll - 0.83 A/R	TS-0620-3142	TS-0620-3143	TS-0203-1261	TS-0203-1061	TS-0203-2002
	179389	Twin Scroll - 0.92 A/R	TS-0620-3142	TS-0620-3143	TS-0203-1261	TS-0203-1061	TS-0203-2002
	179391	Twin Scroll - 1.05 A/R	EXTERNAL WASTEGATE REQUIRED		EXTERNAL BOV RECOMMENDED		TS-0203-2002
EFR-7670 B2	179351	Single Scroll - 0.83 A/R	TS-0620-3142	TS-0620-3143	EXTERNAL BOV RECOMMENDED		TS-0203-2002
	179390	Twin Scroll - 0.92 A/R	TS-0620-3142	TS-0620-3143	EXTERNAL BOV RECOMMENDED		TS-0203-2002
	179392	Twin Scroll - 1.05 A/R	EXTERNAL WASTEGATE REQUIRED		EXTERNAL BOV RECOMMENDED		TS-0203-2002
EFR-8374 B2	179258	Single Scroll - 0.83 A/R	TS-0620-3142	TS-0620-3143	EXTERNAL BOV RECOMMENDED		TS-0203-2002
	179357	Twin Scroll - 0.92 A/R	TS-0620-3142	TS-0620-3143	EXTERNAL BOV RECOMMENDED		TS-0203-2002
	179393	Twin Scroll - 1.05 A/R	EXTERNAL WASTEGATE REQUIRED		EXTERNAL BOV RECOMMENDED		TS-0203-2002
EFR-9180 B2	179358	Single Scroll - 0.83 A/R	TS-0620-3142	TS-0620-3143	EXTERNAL BOV RECOMMENDED		TS-0203-2002
	12809880000	Single Scroll - 0.92 A/R	TS-0620-3142	TS-0620-3143	EXTERNAL BOV RECOMMENDED		TS-0203-2002
	179394	Twin Scroll - 1.05 A/R	EXTERNAL WASTEGATE REQUIRED		EXTERNAL BOV RECOMMENDED		TS-0203-2002

# BOOST CONTROLLERS

## MANUAL BOOST CONTROLLERS

Turbosmart's manual boost controllers are easy to fit, simple in operation, and require little maintenance – making them one of the best “bang for buck” performance mods on the market.

Turbosmart manual boost controllers offer:

- Superior quality
- A small, elegant design
- An easy to use detent adjustment system
- Robust engineering with the one piece body and solid needle valve
- Our exclusive gate feature which brings boost on earlier
- Easy mounting with the supplied bracket
- Anti-tamper locking system

Turbosmart manual boost controllers are perfect for when you need:

- A simple, cost effective solution to boost control
- A reliable mechanical system for harsh or demanding environments
- Boost Tee - The perfect “set it and forget it” boost controller
- In-Cabin - Adjust the boost from the driver's seat
- Dual Stage - Features two adjustable boost levels - Quickly switch between high and low boost using the included rocket launcher switch

Manual Boost Controller Part Numbers	
TS-0101-1001	Boost Tee boost controller - Blue
TS-0101-1002	Boost Tee boost controller - Black
TS-0105-1001	Dual Stage boost controller - Blue
TS-0105-1002	Dual Stage boost controller - Black
TS-0106-1001	In-Cabin boost controller - Blue
TS-0106-1002	In-Cabin boost controller - Black

For spares and accessories go to page 27



## ELECTRONIC BOOST CONTROLLERS

Turbosmart's e-Boost range of electronic boost controllers give you the ultimate control over your boost curve.

Turbosmart electronic boost controllers allow you to control three individual characteristics of your boost, by adjusting three easy to set parameters:

- The maximum boost pressure (set point)
- The spool up rate of the turbocharger (gate pressure)
- And the reaction time of the controller (sensitivity)

**Turbosmart Electronic Boost Controllers:**

- Feature sturdy aluminium cases, for durability and strength
- Can be configured to show PSI, kPa, or BAR on an easy-to-read, three-segment display with adjustable brightness and BAR graph display
- Supplied with a four-port solenoid, solenoid mounting bracket, and vacuum hose

## E-BOOSTHP NEW

Turbosmart's e-BoostHP is a self-contained electronic boost controller capable of handling up to 120 PSI of boost. It can also control water spray, methanol or nitrous injection, manage shift/warning lights and read/monitor RPM.



e-BoostHP Part Numbers	
TS-0301-1120	e-BoostHP 120 PSI 60mm Black face/Black bezel
TS-0301-1121	e-BoostHP 120 PSI 60mm Sleeper - 4 Port



## E-BOOST2

e-Boost2 is the ultimate boost controller, designed with high performance and racing in mind, it is perfect for the tough conditions of track use, and absolutely untouchable in a street application. e-Boost2 is available in two different sizes (60mm and 66mm) and a wide range of colours to suit any interior.

With an e-Boost2 you can:

- Control six levels of boost, with a maximum boost of 60PSI
- Enjoy faster boost response, thanks to Turbosmart's unique Gate Pressure function, and longer boost duration at high RPM via RPM correction factor
- Use Boost on Demand for instant overtaking power
- Set a different boost level for each gear, or if you prefer, program boost against time or RPM
- Control water spray, methanol, nitrous injection, or just about anything else with e-Boost2's handy auxiliary outputs
- Monitor your boost and RPM with Peak Hold/Max Boost recall
- Cruise without a worry thanks to our Overboost Shutdown safety feature

e-Boost2 Part Numbers	
TS-0301-1001	e-Boost2 60PSI 60mm White face/Silver bezel
TS-0301-1014	e-Boost2 60PSI 60mm White face/Black bezel
TS-0301-1002	e-Boost2 60PSI 60mm Black face/Silver bezel
TS-0301-1003	e-Boost2 60PSI 60mm Black face/Black bezel
TS-0301-1103	e-Boost2 60PSI 60mm Sleeper - 4 Port
TS-0301-1004	e-Boost2 60PSI 66mm Silver face/Silver bezel
TS-0301-1005	e-Boost2 60PSI 66mm White face/Black bezel
TS-0301-1013	e-Boost2 60PSI 66mm Black face/Silver bezel
TS-0301-1011	e-Boost2 60PSI 66mm Black face/Black bezel



For spares and accessories go to page 31

# BOOST CONTROLLERS

## E-BOOST STREET

The e-Boost Street is one of the most popular electronic boost controllers on the market. It is easy to use, looks great, and is fantastic at controlling boost! The ideal boost controller for your street car, it features:

- 40psi/2.12BAR max boost operating pressure
- Two boost settings – easily selected via the “turn-and-push” button. An external switch can also be used to change between boost groups
- Boost correction factor eliminates a problem many street cars with standard turbo systems suffer from – boost drop off at high RPM
- Auxiliary output - switch an auxiliary device on or off based on boost and RPM
- Flash warning for over boost shutdown or rev limit
- Easy mounting within a 1/4 DIN size opening
- Display mode: Live display of boost or RPM



e-Boost Street Part Numbers	
TS-0302-1002	e-Boost Street 40psi

For spares and accessories go to page 31

## MANUAL BOOST CONTROLLER PARTS AND ACCESSORIES

Part Number	Description
TS-0101-3001	Replacement Mounting Bracket for 'Boost Tee' and 'In Cabin' Manual Boost Controllers
TS-0105-3002	Replacement Tee Piece for 'In Cabin' and 'Dual Stage' Manual Boost Controllers
TS-0105-3005	Replacement 'Rocket Launcher' style switch suit 'Dual Stage' Manual Boost Controller
TS-0105-3001	Replacement mounting bracket for 'Dual Stage' Manual Boost Controller

## ELECTRONIC BOOST CONTROLLER PARTS AND ACCESSORIES

Part Number	Description
TS-0301-2001	eB2 60mm Dash Mounting System
TS-0301-2002	eB2 60mm Roll Cage Mount
TS-0301-2003	eB2 4 Port Solenoid
TS-0301-2006	eB2 60mm Dual Shift Silver
TS-0301-2007	eB2 60mm Dual Shift Black
TS-0301-2008	eB2 LED- Red
TS-0301-2009	eB2 LED- Green
TS-0301-2010	eB2 LED- Blue
TS-0301-2011	eB2 LED- Orange
TS-0301-2012	eB2 Microswitch
TS-0301-2013	eB2 66mm Dash Mounting System
TS-0301-2014	eB2 66mm Roll Cage Mount
TS-0301-2017	eB2 66mm Dual Shift Silver
TS-0301-2018	eB2 66mm Dual Shift Black
TS-0301-2020	eB2 High Pressure Hose Fitting
TS-0301-3002	eB2 Re-loom System
TS-0301-3003	eB2 Solenoid System
TS-0301-3005	eB2 60mm Replacement Head Unit
TS-0301-3006	eB2 66mm Replacement Head Unit
TS-0302-2001	eBS Mounting Bracket
TS-0302-3002	eBS40 Re-Loom System
TS-0302-3005	eBS Head Unit Replacement



eB2 Dashmount System



Roll Cage Mount System





## WHAT IS FUEL CUT?

Fuel cut is a factory safeguard against boost spikes and boost creep. When the factory ECU senses an increase in boost pressure over a specified fuel cut-out level, it triggers a momentary shutdown of the fuel injectors in order to save the engine from damage.

## WHAT DOES A FUEL CUT DEFENDER DO?

A fuel cut defender raises the fuel cut-out level, allowing you - through the use of a Turbosmart boost controller - to increase boost pressure without the ECU triggering the fuel injector shutdown.

### FCD-1 (PNEUMATIC)

- Suited to most cars using a manifold absolute pressure (MAP) sensor
- Allows an accurate increase in the factory fuel cut-out level
- No need to cut/splice wires
- Does not affect off-boost conditions
- Can be locked to prevent tampering

### FCD-2 (ELECTRONIC)

- Suited to most cars using an Air Flow Meter (AFM)
- Allows an accurate increase in the factory fuel cut-out level
- Features LED indicators for easy set-up
- Adjustable release feature ensures you set your own fuel cut-out level to protect your engine from over-boosting

Fuel Cut Defender Part Numbers	
TS-0303-1001	Fuel Cut Defender FCD-1 (pneumatic)
TS-0303-1002	Fuel Cut Defender FCD-2 (electronic)



# GAUGES

## GAUGES

Turbosmart's new, expanded range of gauges provide access to important information in a stylish, easy-to-read format that looks good in any interior.

With bright backlit illumination and timeless white on black colour scheme with a silver bezel, Turbosmart's interior gauges are available in a variety of applications, both mechanical and electronic.

## ELECTRONIC GAUGES

Our new range of electronic stepper motor-controlled gauges for turbo diesel vehicles includes Exhaust Gas Temperature (EGT), transmission temperature and electronic boost gauges. These gauges are a complete standalone solution, with everything you need to obtain this information from your vehicle - including thermocouples for EGT and transmission temperature gauges, and MAP adapters for electronic boost gauges.

Electrical Gauges Part Numbers	
TS-0701-1011	30PSI Boost Only gauge
TS-0701-1012	60PSI Boost Only gauge
TS-0701-1013	4 Bar Boost Only gauge
TS-0701-3011	Transmission Temperature gauge - Fahrenheit
TS-0701-2011	Exhaust Gas Temperature gauge - Fahrenheit
TS-0740-0002	L Bracket 3 gauge mount



TS-0701-1012



TS-0701-1013



TS-0701-1011

TS-0701-3011

TS-0701-2011

## MECHANICAL BOOST GAUGES

A Turbosmart mechanical boost pressure gauge is the perfect accompaniment to a Turbosmart manual boost controller. Available in both PSI and bar, Turbosmart's mechanical boost gauges are a simple and reliable way to monitor boost pressure.

Mechanical Gauge Part Numbers	
TS-0101-2023	Boost gauge 0-30PSI 52mm
TS-0101-2025	Boost gauge 0-2 Bar 52mm
TS-0101-2024	Boost gauge mounting cup 52mm



TS-0101-2025



TS-0101-2023



TS-0101-2024

# BOOST REFERENCE ADAPTERS



## BRAS (BOOST REFERENCE ADAPTERS)

Many popular modern turbocharged vehicles are incompatible with traditional vacuum-operated accessories, due to the lack of an accessible vacuum source to tap into.

Turbosmart's BRA kit gives the vehicle a boost reference source, and is a must for anyone planning to add a Blow-Off Valve, mechanical boost gauge or other vacuum-operated accessories to such a vehicle.

Turbosmart's Boost Reference Adapter kits include everything you need to reliably obtain a boost reference from a wide range of vehicles. For vehicle specific applications, please refer to fitment guide on pages 47-59.

BRAS Part Numbers	
TS-0720-1001	Mazda BT50 - Black
TS-0720-1002	VW Golf GTI MK5/6 - Black
TS-0720-1003	Ford Fiesta Ecoboost 2015-current - Black
TS-0720-1004	Ford Mustang 2015-current - Black
TS-0720-1005	Ford F150 2013+ Ecoboost - Black
TS-0720-1006	Mini Cooper/S R56/ Renault Clio RS - Black
TS-0720-1008	Nissan TD42T/ZD30DDTi Engine - Black
TS-0720-1010	VW Golf GTI/R MK7 - Black



TS-0720-1001



TS-0720-1002



TS-0720-1003



TS-0720-1004



TS-0720-1005



TS-0720-1006



TS-0720-1008



TS-0720-1010

BLOW-OFF VALVES  
WASTEGATES  
BOOST CONTROLLERS  
FUEL CUT DEFENDERS  
GAUGES/BRAS  
FUEL PRESSURE REGULATORS  
FUEL RAIL ADAPTERS  
FUEL FILTERS/OPRS  
SILICONE HOSE  
PRODUCT FITMENT GUIDE

# FUEL PRESSURE REGULATORS



## WHAT IS A FUEL PRESSURE REGULATOR?

A fuel pressure regulator is a device that maintains a constant pressure difference between fuel pressure and manifold air pressure.

Fuel injectors are designed to spray fuel into the engine in a perfect spray pattern. When an engine is boosted, the rise in air pressure in the manifold can affect the injector's spray pattern - which can cause poor engine performance, or engine failure.

A fuel pressure regulator lets you set a base fuel pressure, then as boost pressure rises, the regulator increases the fuel pressure at a perfect 1:1 ratio, to ensure fuel is being delivered to your fuel injectors at the correct pressure. This is particularly important if performance injectors, or high-flow fuel pumps, have been installed.

## WHICH FUEL PRESSURE REGULATOR IS RIGHT FOR MY APPLICATION?

A fuel pressure regulator is sized according to how much fuel it is able to return to the fuel tank, while maintaining an optimum fuel pressure. When high flow fuel pumps are installed into a fuel system, the fuel pressure regulator must be able to match the flow of the new pumps.

A Turbosmart FPR800 is rated to '800HP' not on its ability to support an 800HP engine, rather its ability to flow 800HP worth of fuel back to the tank when it's not needed by the fuel injectors. Therefore Turbosmart fuel pressure regulators are chosen to match the capacity of the fuel system.

Other factors to consider when choosing a Turbosmart fuel pressure regulator include what kind of lines are being used (rubber push on or screw in -AN fittings), and whether or not your fuel rail is aftermarket (requiring the use of custom fuel lines).

All Turbosmart fuel pressure regulators:

- Are manufactured from billet aluminium and hand assembled for maximum precision
- Maintain a 1:1 Fuel/Air Pressure Ratio
- Allow 35-70PSI base pressure adjustments
- Are supplied with a mounting bracket, vacuum fitting and gauge port plug



### FPR800 **NEW**

- Ideal for vehicles running 800HP fuel systems
- 1/8 NPT inlet and outlet ports, 1/8 NPT gauge port

FPR800 V2 Part Numbers	
TS-0401-1101	FPR 800 - Blue
TS-0401-1102	FPR 800 - Black



### FPR1200 **NEW**

- Ideal for vehicles running 1200HP fuel systems
- -6AN inlet and outlet ports, 1/8 NPT gauge port
- Suitable for all pump and race fuels

FPR1200 V2 Part Numbers	
TS-0401-1103	FPR 1200 - Blue
TS-0401-1104	FPR 1200 - Black



### FPR2000 **NEW**

- Ideal for vehicles running 2000HP fuel systems
- Great for use with mechanical pumps
- -8AN inlet and outlet ports, 1/8 NPT gauge port
- Supplied with -3AN vacuum/pressure port adaptor
- Suitable for all pump and race fuels

FPR2000 Part Numbers	
TS-0401-1105	FPR 2000 - Blue
TS-0401-1106	FPR 2000 - Black

### FUEL PRESSURE REGULATOR PARTS AND ACCESSORIES

Part Number	Description
TS-0402-2023	FPR Gauge 0-100psi Liquid Fill
<b>FPR800</b>	
TS-0402-1107	FPR Fitting Kit 1/8NPT to 6mm
TS-0402-1108	FPR Fitting Kit 1/8NPT to 8mm
TS-0402-1115	FPR Fitting Kit 1/8NPT - 10mm
TS-0402-1112	FPR Fitting Kit 1/8NPT to -6AN
TS-0402-1123	FPR 1/8 NPT Male - 1/8 NPT Female 90°
<b>FPR1200</b>	
TS-0402-1109	FPR Fitting Kit -6 AN to 6mm
TS-0402-1110	FPR Fitting Kit -6 AN to 8mm
TS-0402-1116	FPR Fitting Kit -6 AN to 10mm
TS-0402-1111	FPR Fitting Kit -6AN to -6AN

### PREVIOUS VERSION FUEL PRESSURE REGULATOR PARTS AND ACCESSORIES

Part Number	Description
TS-0401-3005	FPR Mounting Bracket Replacement
<b>FPR800</b>	
TS-0401-3101	FPR800 Replacement Diaphragm Assembly
<b>FPR1200</b>	
TS-0401-3102	FPR1200 Replacement Diaphragm Assembly
<b>FPR2000</b>	
TS-0401-3003	FPR2000 Replacement Diaphragm Assembly

# FUEL RAIL ADAPTERS

## FUEL RAIL ADAPTERS

Turbosmart fuel rail adapters allow for fitment of a Turbosmart fuel pressure regulator to the following OEM fuel rails:

Make	Model	Engine	Part Number
Audi	A3	1.8T 20v	TS-0402-1006
Audi	A4	1.8T 20v	TS-0402-1006
Audi	A6	1.8T 20v	TS-0402-1006
Audi	S3	1.8T 20v	TS-0402-1006
Audi	TT	1.8T 20v	TS-0402-1006

Make	Model	Engine	Part Number
Ford	XR6 BA Turbo	4.0l Barra	TS-0402-1006
Ford	XR6 BF Turbo	4.0l Barra	TS-0402-1006
Ford	XR6 FG Turbo	4.0l Barra	TS-0402-1006
Ford	Territory Turbo	4.0l Barra	TS-0402-1006

Make	Model	Engine	Part Number
Mitsubishi	Lancer Evolution 4	4G63	TS-0402-1005
Mitsubishi	Lancer Evolution 5	4G63	TS-0402-1005
Mitsubishi	Lancer Evolution 6	4G63	TS-0402-1005
Mitsubishi	Lancer Evolution 7	4G63	TS-0402-1005
Mitsubishi	Lancer Evolution 8	4G63	TS-0402-1005
Mitsubishi	Lancer Evolution 9	4G63	TS-0402-1005
Mitsubishi	Lancer Evolution 10	4B11T	TS-0402-1014
Mitsubishi	FTO	6A12 MIVEC	TS-0402-1005

Make	Model	Engine	Part Number
Nissan	PS13 Silvia	CA18DET	TS-0402-1001
Nissan	RPS13 180SX	CA18DET	TS-0402-1001
Nissan	Skyline R32 GTS-25	RB25DE	TS-0402-1001
Nissan	Skyline R33 GTS-T	RB25DET	TS-0402-1001
Nissan	Skyline R34 GTS-T	RB25DET	TS-0402-1001
Nissan	Skyline R32 GT-R	RB26DETT	TS-0402-1001
Nissan	Skyline R33 GT-R	RB26DETT	TS-0402-1001
Nissan	Skyline R34 GT-R	RB26DETT	TS-0402-1001
Nissan	PS13 Silvia	SR20DET	TS-0402-1001
Nissan	RPS13 180SX	SR20DET	TS-0402-1001
Nissan	S14 Silvia/200SX	SR20DET	TS-0402-1001
Nissan	S15 Silvia/200SX	SR20DET	TS-0402-1001

Make	Model	Engine	Part Number
Subaru	GC8/GF8 WRX	EJ205	TS-0402-1001
Subaru	Liberty/Outback up to MY00	EJ205	TS-0402-1001
Subaru	GC8/GF8 WRX STi	EJ207	TS-0402-1001
Subaru	GRB WRX (2008 - 2014)	EJ255	TS-0402-1001
Subaru	Forrester (2008 - 2014)	EJ255	TS-0402-1001
Subaru	Liberty (2005 - 2014)	EJ255	TS-0402-1001
Subaru	GDA WRX (2001 - 2008)	EJ205	TS-0402-1002
Subaru	WRX STi (2008 - 2014)	EJ257	TS-0402-1013

Make	Model	Engine	Part Number
Toyota	Supra JZ80	2JZ-GTE	TS-0402-1002
Toyota	Aristo JZ147	2JZ-GTE	TS-0402-1002
Toyota	Corolla	4AGE	TS-0402-1002
Toyota	Corolla	4AGZE	TS-0402-1002
Toyota	Starlet EP	4EFTE	TS-0402-1002
Toyota	Supra	1JZ-GTE	TS-0402-1003
Toyota	Cresta	1JZ-GTE	TS-0402-1003
Toyota	Chaser	1JZ-GTE	TS-0402-1003
Toyota	Mark II	1JZ-GTE	TS-0402-1003
Toyota	Soarer	1UZ-FE	TS-0402-1003
Toyota	MR2	3S-GTE	TS-0402-1003
Toyota	Celica GT4	3S-GTE	TS-0402-1003

Make	Model	Engine	Part Number
VW	Beetle (1998-2011)	1.8T 20v	TS-0402-1006



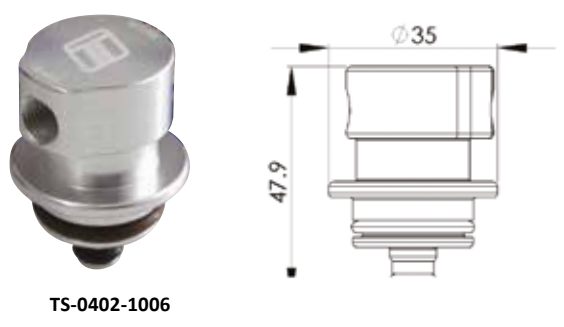
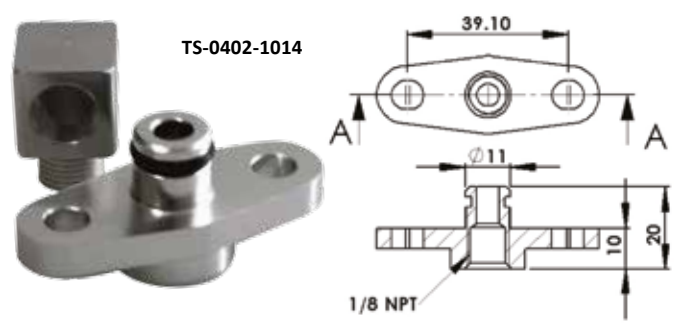
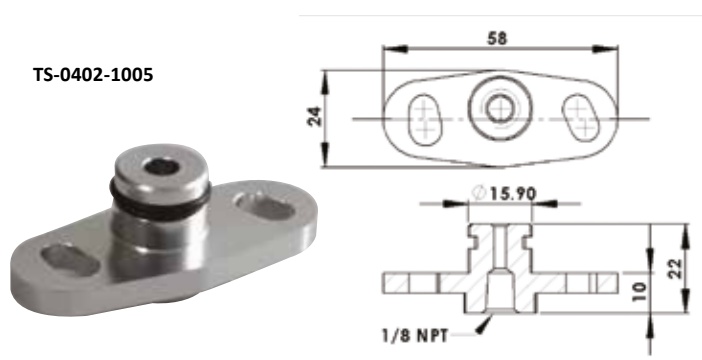
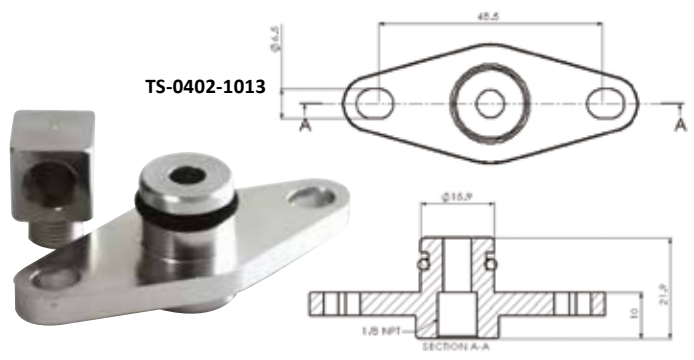
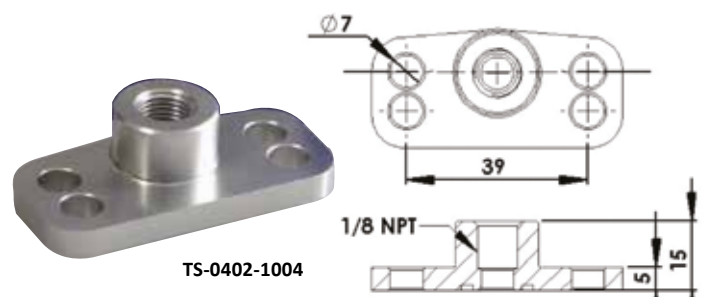
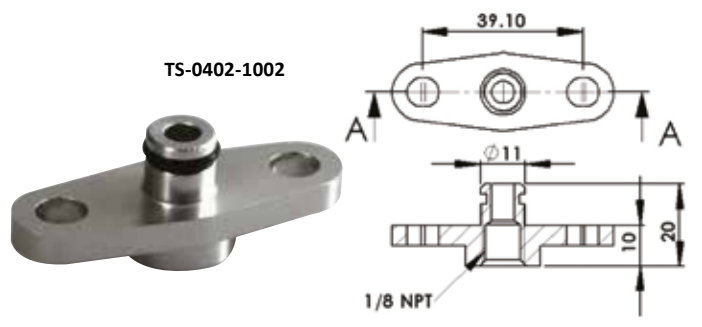
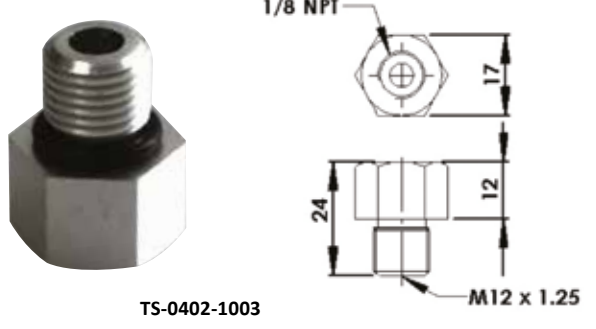
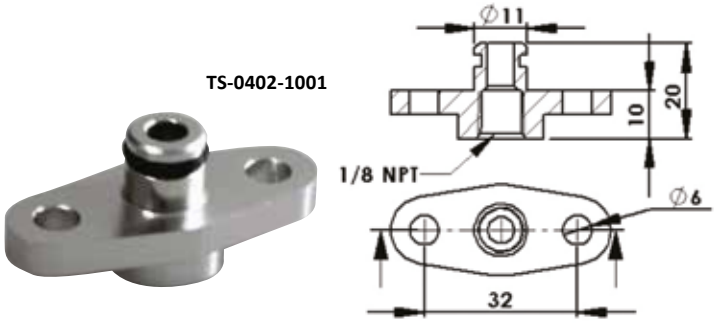

# FUEL FILTERS

## FUEL FILTERS **NEW**

The new range of billet fuel filters provides the perfect accompaniment to Turbosmart's Fuel Pressure Regulators. They are available in three sizes to suit different fuel systems and FPRs, with -6AN, -8AN and -10AN fitting sizes.

A 10 micron stainless steel filter element ensures the engine receives clean fuel, free of the finest particles, while the filter element itself is replaceable and available separately, meaning minimal cost come service time.



Fuel Filter Part Numbers	
TS-0402-1130	Fuel Filter 10um AN-6 - Black
TS-0402-1131	Fuel Filter 10um AN-8 - Black
TS-0402-1132	Fuel Filter 10um AN-10 - Black
TS-0402-1140	Fuel Filter Bracket - Black



TS-0402-1130



TS-0402-1131



TS-0402-1132







## TURBO OIL PRESSURE REGULATOR (OPR) **NEW** Patent Pending

Turbosmart's new patent pending OPR T40 is an oil pressure regulation system for your turbocharger.

The oil regulator ensures the oil pressure going to the turbocharger never exceeds the maximum pressure turbocharger manufacturers specify for oil supply, regardless of engine oil pressure.

The result is an oil delivery system that is more reliable and easier to setup than a standard restrictor system, especially when combined with Turbosmart's new range of turbo fittings and filters.



Turbo Oil Pressure Regulator Part Numbers	
TS-0801-1001	OPR T40 40psi - Blue
TS-0801-1002	OPR T40 40psi - Black



## TURBO OIL FEED FILTERS AND DRAIN ADAPTERS **NEW**

Turbosmart's turbo oil feed filters make sure your turbo is always fed with clean oil. With small oil galleries, it's highly important for the turbocharger to avoid any debris that may become dislodged from the engine, and a 44 micron filter element ensures even the smallest particles are kept away from the turbo. The perfect combination with Turbosmart's new Turbo Oil Regulator, the oil feed filters are available two fitting sizes, -3AN and -4AN. Turbosmart's hard anodized billet turbo oil drain flange adapters offer a reliable plug-and-play solution to fit turbocharger's oil drain to a -8AN or -10AN fitting.



Turbo Oil Feed Filters/Drain Adapters Part Numbers	
TS-0804-1001	Billet Turbo Oil Feed Filter 44um AN-3 - Black
TS-0804-1002	Billet Turbo Oil Feed Filter 44um AN-4 - Black
TS-0804-1010	Billet Turbo Drain Adapter 38-44mm slotted Uni small frame
TS-0804-1011	Billet Turbo Drain Adapter 52mm T3/T4 Frame
TS-0804-1012	Billet Turbo Drain Adapter 52.4mm Large Frame Uni
TS-0804-1020	Billet Turbo Drain 70mm Extension -8 MALE to -8 PORT
TS-0804-1021	Billet Turbo Drain 70mm Extension -10 MALE to -10 PORT



BLOW-OFF VALVES

WASTEGATES

BOOST CONTROLLERS

FUEL CUT DEFENDERS

GAUGES/BRAS

FUEL PRESSURE REGULATORS

FUEL RAIL ADAPTERS

FUEL FILTERS/OPRS

SILICONE HOSE

PRODUCT FITMENT GUIDE

# SILICONE HOSE

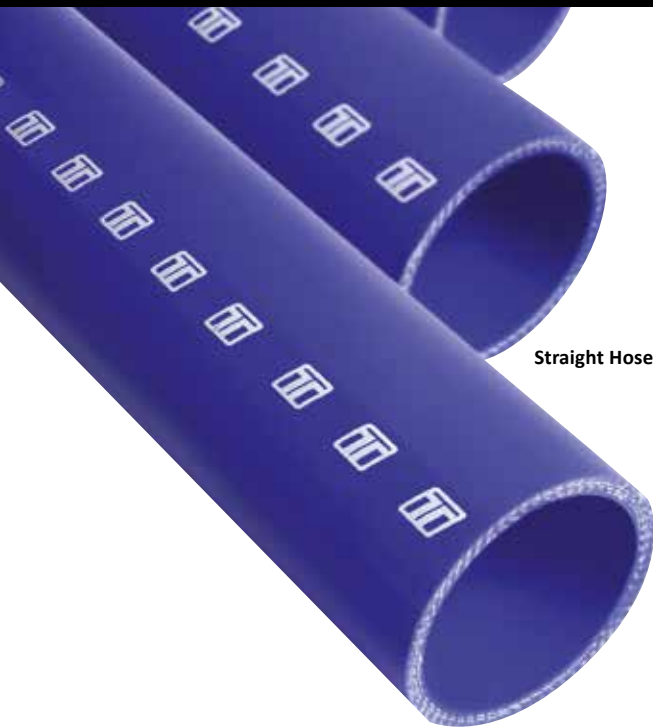

Straight Hose

## WHY UPGRADE TO SILICONE?

Turbosmart silicone hoses are:

- Manufactured from a high-grade silicone
- Stronger, tougher and more flexible than rubber hoses
- Temperature resistant from -50°C (-58°F) to 170°C (338°F) constant
- Available in a wide range of styles and diameters
- Available in Blue and in Black

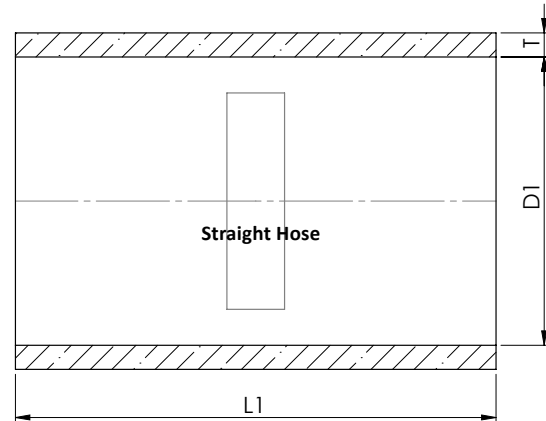

## STRAIGHT HOSE - PRECUT LENGTHS

Part Number	D1	L1	Colour	Ply	T
TS-HS100060-BE	1.00" (25mm)	2.375" (60mm)	Blue	3	4.5mm
TS-HS100060-BK	1.00" (25mm)	2.375" (60mm)	Black	3	4.5mm
TS-HS110060-BE	1.10" (28mm)	2.375" (60mm)	Blue	3	4.5mm
TS-HS110060-BK	1.10" (28mm)	2.375" (60mm)	Black	3	4.5mm
TS-HS125060-BE	1.25" (32mm)	2.375" (60mm)	Blue	3	4.5mm
TS-HS125060-BK	1.25" (32mm)	2.375" (60mm)	Black	3	4.5mm
TS-HS150060-BE	1.50" (38mm)	2.375" (60mm)	Blue	3	4.5mm
TS-HS150060-BK	1.50" (38mm)	2.375" (60mm)	Black	3	4.5mm
TS-HS175060-BE	1.75" (45mm)	2.375" (60mm)	Blue	3	4.5mm
TS-HS175060-BK	1.75" (45mm)	2.375" (60mm)	Black	3	4.5mm
TS-HS200075-BE	2.00" (50mm)	3.00" (75mm)	Blue	3	4.5mm
TS-HS200075-BK	2.00" (50mm)	3.00" (75mm)	Black	3	4.5mm
TS-HS225075-BE	2.25" (57mm)	3.00" (75mm)	Blue	4	5mm
TS-HS225075-BK	2.25" (57mm)	3.00" (75mm)	Black	4	5mm
TS-HS236075-BE	2.36" (60mm)	3.00" (75mm)	Blue	4	5mm
TS-HS236075-BK	2.36" (60mm)	3.00" (75mm)	Black	4	5mm
TS-HS250075-BE	2.50" (63mm)	3.00" (75mm)	Blue	4	5mm
TS-HS250075-BK	2.50" (63mm)	3.00" (75mm)	Black	4	5mm
TS-HS275075-BE	2.75" (70mm)	3.00" (75mm)	Blue	4	5mm
TS-HS275075-BK	2.75" (70mm)	3.00" (75mm)	Black	4	5mm
TS-HS300075-BE	3.00" (75mm)	3.00" (75mm)	Blue	4	5mm
TS-HS300075-BK	3.00" (75mm)	3.00" (75mm)	Black	4	5mm
TS-HS325090-BE	3.25" (83mm)	3.50" (90mm)	Blue	4	5mm
TS-HS325090-BK	3.25" (83mm)	3.50" (90mm)	Black	4	5mm
TS-HS350090-BE	3.50" (89mm)	3.50" (90mm)	Blue	4	5mm
TS-HS350090-BK	3.50" (89mm)	3.50" (90mm)	Black	4	5mm
TS-HS375090-BE	3.75" (95mm)	3.50" (90mm)	Blue	4	5mm
TS-HS375090-BK	3.75" (95mm)	3.50" (90mm)	Black	4	5mm
TS-HS400090-BE	4.00" (102mm)	3.50" (90mm)	Blue	4	5mm
TS-HS400090-BK	4.00" (102mm)	3.50" (90mm)	Black	4	5mm

## STRAIGHT HOSE - FULL LENGTHS

Part Number	D1	L1	Colour	Ply	T
TS-HS100610-BE	1.00" (25mm)	2' (610mm)	Blue	3	4.5mm
TS-HS100610-BK	1.00" (25mm)	2' (610mm)	Black	3	4.5mm
TS-HS110610-BE	1.10" (28mm)	2' (610mm)	Blue	3	4.5mm
TS-HS110610-BK	1.10" (28mm)	2' (610mm)	Black	3	4.5mm
TS-HS125610-BE	1.25" (32mm)	2' (610mm)	Blue	3	4.5mm
TS-HS125610-BK	1.25" (32mm)	2' (610mm)	Black	3	4.5mm
TS-HS150610-BE	1.50" (38mm)	2' (610mm)	Blue	3	4.5mm
TS-HS150610-BK	1.50" (38mm)	2' (610mm)	Black	3	4.5mm
TS-HS175610-BE	1.75" (45mm)	2' (610mm)	Blue	3	4.5mm
TS-HS175610-BK	1.75" (45mm)	2' (610mm)	Black	3	4.5mm
TS-HS200610-BE	2.00" (50mm)	2' (610mm)	Blue	3	4.5mm
TS-HS200610-BK	2.00" (50mm)	2' (610mm)	Black	3	4.5mm
TS-HS225610-BE	2.25" (57mm)	2' (610mm)	Blue	4	5mm
TS-HS225610-BK	2.25" (57mm)	2' (610mm)	Black	4	5mm
TS-HS250610-BE	2.50" (63mm)	2' (610mm)	Blue	4	5mm
TS-HS250610-BK	2.50" (63mm)	2' (610mm)	Black	4	5mm
TS-HS275610-BE	2.75" (70mm)	2' (610mm)	Blue	4	5mm
TS-HS275610-BK	2.75" (70mm)	2' (610mm)	Black	4	5mm
TS-HS300610-BE	3.00" (75mm)	2' (610mm)	Blue	4	5mm
TS-HS300610-BK	3.00" (75mm)	2' (610mm)	Black	4	5mm
TS-HS325610-BE	3.25" (83mm)	2' (610mm)	Blue	4	5mm
TS-HS325610-BK	3.25" (83mm)	2' (610mm)	Black	4	5mm
TS-HS350610-BE	3.50" (89mm)	2' (610mm)	Blue	4	5mm
TS-HS350610-BK	3.50" (89mm)	2' (610mm)	Black	4	5mm
TS-HS375610-BE	3.75" (95mm)	2' (610mm)	Blue	4	5mm
TS-HS375610-BK	3.75" (95mm)	2' (610mm)	Black	4	5mm
TS-HS400610-BE	4.00" (102mm)	2' (610mm)	Blue	4	5mm
TS-HS400610-BK	4.00" (102mm)	2' (610mm)	Black	4	5mm

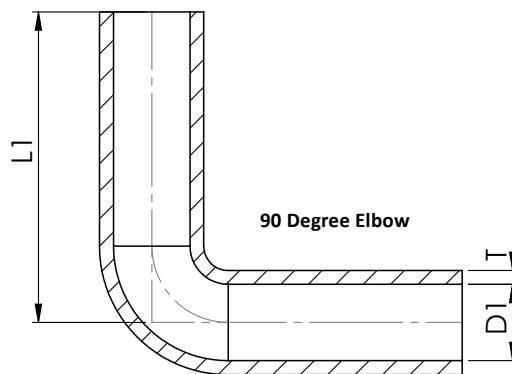
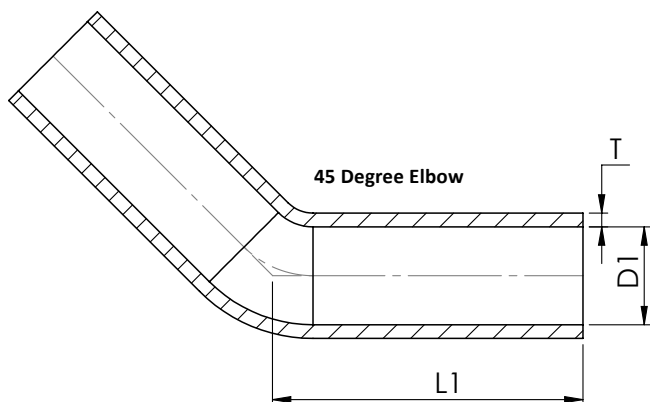

### 45 DEGREE ELBOWS

Part Number	D1	L1	Colour	Ply	T
TS-HE45075-BE	0.75" (19mm)	102mm	Blue	3	4.5mm
TS-HE45075-BK	0.75" (19mm)	102mm	Black	3	4.5mm
TS-HE45100-BE	1.00" (25mm)	102mm	Blue	3	4.5mm
TS-HE45100-BK	1.00" (25mm)	102mm	Black	3	4.5mm
TS-HE45125-BE	1.25" (32mm)	102mm	Blue	3	4.5mm
TS-HE45125-BK	1.25" (32mm)	102mm	Black	3	4.5mm
TS-HE45150-BE	1.50" (38mm)	102mm	Blue	3	4.5mm
TS-HE45150-BK	1.50" (38mm)	102mm	Black	3	4.5mm
TS-HE45175-BE	1.75" (45mm)	102mm	Blue	3	4.5mm
TS-HE45175-BK	1.75" (45mm)	102mm	Black	3	4.5mm
TS-HE45200-BE	2.00" (50mm)	102mm	Blue	3	4.5mm
TS-HE45200-BK	2.00" (50mm)	102mm	Black	3	4.5mm
TS-HE45225-BE	2.25" (57mm)	102mm	Blue	4	5mm
TS-HE45225-BK	2.25" (57mm)	102mm	Black	4	5mm
TS-HE45250-BE	2.50" (63mm)	102mm	Blue	4	5mm
TS-HE45250-BK	2.50" (63mm)	102mm	Black	4	5mm
TS-HE45275-BE	2.75" (70mm)	102mm	Blue	4	5mm
TS-HE45275-BK	2.75" (70mm)	102mm	Black	4	5mm
TS-HE45300-BE	3.00" (76mm)	102mm	Blue	4	5mm
TS-HE45300-BK	3.00" (76mm)	102mm	Black	4	5mm
TS-HE45350-BE	3.50" (89mm)	127mm	Blue	4	5mm
TS-HE45350-BK	3.50" (89mm)	127mm	Black	4	5mm
TS-HE45400-BE	4.00" (102mm)	127mm	Blue	4	5mm
TS-HE45400-BK	4.00" (102mm)	127mm	Black	4	5mm

### 90 DEGREE ELBOWS

Part Number	D1	L1	Colour	Ply	T
TS-HE90100-BE	1.00" (25mm)	102mm	Blue	3	4.5mm
TS-HE90100-BK	1.00" (25mm)	102mm	Black	3	4.5mm
TS-HE90125-BE	1.25" (32mm)	102mm	Blue	3	4.5mm
TS-HE90125-BK	1.25" (32mm)	102mm	Black	3	4.5mm
TS-HE90150-BE	1.50" (38mm)	102mm	Blue	3	4.5mm
TS-HE90150-BK	1.50" (38mm)	102mm	Black	3	4.5mm
TS-HE90175-BE	1.75" (45mm)	102mm	Blue	3	4.5mm
TS-HE90175-BK	1.75" (45mm)	102mm	Black	3	4.5mm
TS-HE90200-BE	2.00" (50mm)	102mm	Blue	3	4.5mm
TS-HE90200-BK	2.00" (50mm)	102mm	Black	3	4.5mm
TS-HE90225-BE	2.25" (57mm)	102mm	Blue	4	5mm
TS-HE90225-BK	2.25" (57mm)	102mm	Black	4	5mm
TS-HE90250-BE	2.50" (63mm)	127mm	Blue	4	5mm
TS-HE90250-BK	2.50" (63mm)	127mm	Black	4	5mm
TS-HE90275-BE	2.75" (70mm)	152mm	Blue	4	5mm
TS-HE90275-BK	2.75" (70mm)	152mm	Black	4	5mm
TS-HE90300-BE	3.00" (76mm)	152mm	Blue	4	5mm
TS-HE90300-BK	3.00" (76mm)	152mm	Black	4	5mm
TS-HE90350-BE	3.50" (89mm)	152mm	Blue	4	5mm
TS-HE90350-BK	3.50" (89mm)	152mm	Black	4	5mm
TS-HE90400-BE	4.00" (102mm)	152mm	Blue	4	5mm
TS-HE90400-BK	4.00" (102mm)	152mm	Black	4	5mm



# SILICONE HOSE

## VACUUM HOSE

Part Number	ID	OD	Length	Colour
TS-HV0303-BE	3mm	8mm	3m	Blue
TS-HV0303-BK	3mm	8mm	3m	Black
TS-HV0303-RD	3mm	8mm	3m	Red
TS-HV0403-BE	4mm	9mm	3m	Blue
TS-HV0403-BK	4mm	9mm	3m	Black
TS-HV0403-RD	4mm	9mm	3m	Red
TS-HV0503-BE	5mm	10mm	3m	Blue
TS-HV0503-BK	5mm	10mm	3m	Black
TS-HV0503-RD	5mm	10mm	3m	Red
TS-HV0603-BE	6mm	11mm	3m	Blue
TS-HV0603-BK	6mm	11mm	3m	Black
TS-HV0603-RD	6mm	11mm	3m	Red

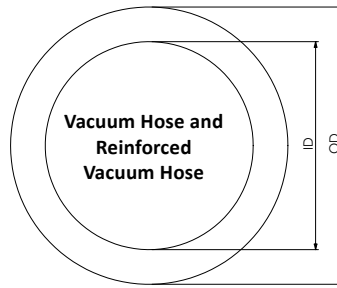

## REINFORCED VACUUM HOSE

Part Number	Inside Diameter	Outside Diameter	Length	Colour
TS-HH06303-BE	6.3mm	13mm	3m	Blue
TS-HH06303-BK	6.3mm	13mm	3m	Black

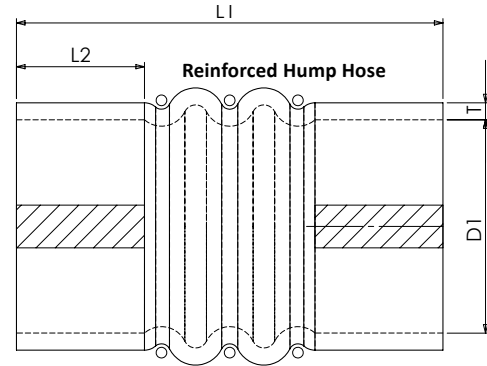

## REINFORCED HUMP HOSES

Part Number	D1	L1	L2	Colour	Ply	T
TS-HH200-BE	2.00" (50mm)	100mm	30mm	Blue	4	5mm
TS-HH200-BK	2.00" (50mm)	100mm	30mm	Black	4	5mm
TS-HH225-BE	2.25" (57mm)	114mm	35mm	Blue	4	5mm
TS-HH225-BK	2.25" (57mm)	114mm	35mm	Black	4	5mm
TS-HH250-BE	2.50" (63mm)	126mm	37mm	Blue	4	5mm
TS-HH250-BK	2.50" (63mm)	126mm	37mm	Black	4	5mm
TS-HH275-BE	2.75" (70mm)	140mm	40mm	Blue	4	5mm
TS-HH275-BK	2.75" (70mm)	140mm	40mm	Black	4	5mm
TS-HH300-BE	3.00" (75mm)	152mm	45mm	Blue	4	5mm
TS-HH300-BK	3.00" (75mm)	152mm	45mm	Black	4	5mm
TS-HH350-BE	3.50" (89mm)	178mm	55mm	Blue	4	5mm
TS-HH350-BK	3.50" (89mm)	178mm	55mm	Black	4	5mm
TS-HH400-BE	4.00" (102mm)	204mm	60mm	Blue	4	5mm
TS-HH400-BK	4.00" (102mm)	204mm	60mm	Black	4	5mm

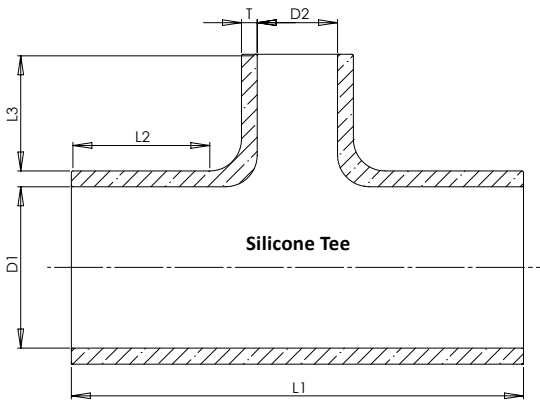

## SILICONE TEES

Part Number	D1	D2	L1	L2	L3	Colour	Ply	T
TS-HT200100-BE	2.00" (50mm)	1.00" (25mm)	143mm	44mm	37mm	Blue	4	5mm
TS-HT200150-BE	2.00" (50mm)	1.50" (38mm)	143mm	38mm	37mm	Blue	4	5mm
TS-HT200150-BK	2.00" (50mm)	1.50" (38mm)	143mm	38mm	37mm	Black	4	5mm
TS-HT225150-BE	2.25" (57mm)	1.50" (38mm)	143mm	38mm	37mm	Blue	4	5mm
TS-HT225150-BK	2.25" (57mm)	1.50" (38mm)	143mm	38mm	37mm	Black	4	5mm
TS-HT250100-BE	2.50" (63mm)	1.00" (25mm)	143mm	44mm	37mm	Blue	4	5mm
TS-HT250150-BE	2.50" (63mm)	1.50" (38mm)	143mm	38mm	37mm	Blue	4	5mm
TS-HT250150-BK	2.50" (63mm)	1.50" (38mm)	143mm	38mm	37mm	Black	4	5mm
TS-HT275150-BE	2.75" (70mm)	1.50" (38mm)	143mm	38mm	37mm	Blue	4	5mm
TS-HT275150-BK	2.75" (70mm)	1.50" (38mm)	143mm	38mm	37mm	Black	4	5mm
TS-HT300150-BE	3.00" (75mm)	1.50" (38mm)	158mm	45mm	38mm	Blue	4	5mm
TS-HT300150-BK	3.00" (75mm)	1.50" (38mm)	158mm	45mm	38mm	Black	4	5mm

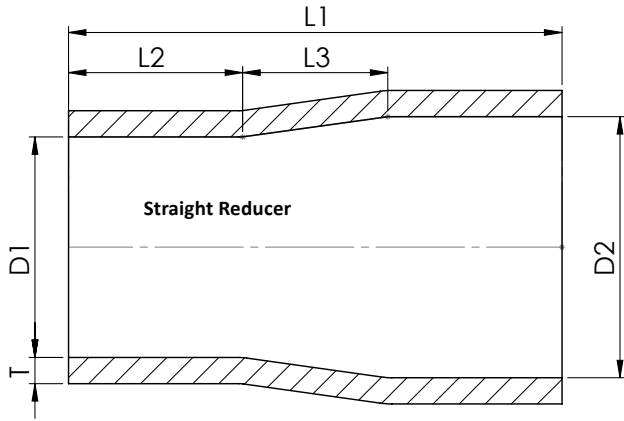

**Straight Reducer**

**STRAIGHT REDUCERS**

Part Number	D1	D2	L1	L2	L3	Colour	Ply	T
TS-HR125175-BE	1.25" (32mm)	1.75" (45mm)	85mm	30mm	25mm	Blue	3	4.5mm
TS-HR125175-BK	1.25" (32mm)	1.75" (45mm)	85mm	30mm	25mm	Black	3	4.5mm
TS-HR150175-BE	1.50" (38mm)	1.75" (45mm)	85mm	30mm	25mm	Blue	3	4.5mm
TS-HR150175-BK	1.50" (38mm)	1.75" (45mm)	85mm	30mm	25mm	Black	3	4.5mm
TS-HR150200-BE	1.50" (38mm)	2.00" (50mm)	100mm	37mm	25mm	Blue	3	4.5mm
TS-HR150200-BK	1.50" (38mm)	2.00" (50mm)	100mm	37mm	25mm	Black	3	4.5mm
TS-HR175200-BE	1.75" (45mm)	2.00" (50mm)	100mm	37mm	25mm	Blue	3	4.5mm
TS-HR175200-BK	1.75" (45mm)	2.00" (50mm)	100mm	37mm	25mm	Black	3	4.5mm
TS-HR175225-BE	1.75" (45mm)	2.25" (57mm)	100mm	37mm	25mm	Blue	3	4.5mm
TS-HR175225-BK	1.75" (45mm)	2.25" (57mm)	100mm	37mm	25mm	Black	3	4.5mm
TS-HR175300-BE	1.75" (45mm)	3.00" (75mm)	100mm	37mm	25mm	Blue	3	4.5mm
TS-HR175300-BK	1.75" (45mm)	3.00" (75mm)	100mm	37mm	25mm	Black	3	4.5mm
TS-HR200225-BE	2.00" (50mm)	2.25" (57mm)	100mm	37mm	25mm	Blue	4	5mm
TS-HR200225-BK	2.00" (50mm)	2.25" (57mm)	100mm	37mm	25mm	Black	4	5mm
TS-HR200250-BE	2.00" (50mm)	2.50" (63mm)	100mm	37mm	25mm	Blue	4	5mm
TS-HR200250-BK	2.00" (50mm)	2.50" (63mm)	100mm	37mm	25mm	Black	4	5mm
TS-HR200275-BE	2.00" (50mm)	2.75" (70mm)	100mm	37mm	25mm	Blue	4	5mm
TS-HR200275-BK	2.00" (50mm)	2.75" (70mm)	100mm	37mm	25mm	Black	4	5mm
TS-HR200300-BE	2.00" (50mm)	3.00" (75mm)	100mm	37mm	25mm	Blue	4	5mm
TS-HR200300-BK	2.00" (50mm)	3.00" (75mm)	100mm	37mm	25mm	Black	4	5mm
TS-HR200325-BE	2.00" (50mm)	3.25" (83mm)	100mm	37mm	25mm	Blue	4	5mm
TS-HR200325-BK	2.00" (50mm)	3.25" (83mm)	100mm	37mm	25mm	Black	4	5mm
TS-HR225250-BE	2.25" (57mm)	2.50" (63mm)	100mm	37mm	25mm	Blue	4	5mm
TS-HR225250-BK	2.25" (57mm)	2.50" (63mm)	100mm	37mm	25mm	Black	4	5mm
TS-HR225275-BE	2.25" (57mm)	2.75" (70mm)	100mm	37mm	25mm	Blue	4	5mm
TS-HR225275-BK	2.25" (57mm)	2.75" (70mm)	100mm	37mm	25mm	Black	4	5mm
TS-HR225300-BE	2.25" (57mm)	3.00" (75mm)	100mm	37mm	25mm	Blue	4	5mm
TS-HR225300-BK	2.25" (57mm)	3.00" (75mm)	100mm	37mm	25mm	Black	4	5mm
TS-HR250275-BE	2.50" (63mm)	2.75" (70mm)	100mm	37mm	25mm	Blue	4	5mm
TS-HR250275-BK	2.50" (63mm)	2.75" (70mm)	100mm	37mm	25mm	Black	4	5mm
TS-HR250300-BE	2.50" (63mm)	3.00" (75mm)	100mm	37mm	25mm	Blue	4	5mm
TS-HR250300-BK	2.50" (63mm)	3.00" (75mm)	100mm	37mm	25mm	Black	4	5mm
TS-HR250325-BE	2.50" (63mm)	3.25" (83mm)	115mm	45mm	25mm	Blue	4	5mm
TS-HR250325-BK	2.50" (63mm)	3.25" (83mm)	115mm	45mm	25mm	Black	4	5mm
TS-HR275300-BE	2.75" (70mm)	3.00" (75mm)	100mm	37mm	25mm	Blue	4	5mm

# SILICONE HOSE

## Straight Reducers Continued.

Part Number	D1	D2	L1	L2	L3	Colour	Ply	T
TS-HR275300-BK	2.75" (70mm)	3.00" (75mm)	100mm	37mm	25mm	Black	4	5mm
TS-HR275350-BE	2.75" (70mm)	3.50" (89mm)	115mm	45mm	25mm	Blue	4	5mm
TS-HR275350-BK	2.75" (70mm)	3.50" (89mm)	115mm	45mm	25mm	Black	4	5mm
TS-HR300325-BE	3.00" (75mm)	3.25" (83mm)	115mm	37mm	25mm	Blue	4	5mm
TS-HR300325-BK	3.00" (75mm)	3.25" (83mm)	115mm	37mm	25mm	Black	4	5mm
TS-HR300350-BE	3.00" (75mm)	3.50" (89mm)	115mm	45mm	25mm	Blue	4	5mm
TS-HR300350-BK	3.00" (75mm)	3.50" (89mm)	115mm	45mm	25mm	Black	4	5mm
TS-HR300375-BE	3.00" (75mm)	3.75" (95mm)	115mm	45mm	25mm	Blue	4	5mm
TS-HR300375-BK	3.00" (75mm)	3.75" (95mm)	115mm	45mm	25mm	Black	4	5mm
TS-HR300400-BE	3.00" (75mm)	4.00" (102mm)	115mm	45mm	25mm	Blue	4	5mm
TS-HR300400-BK	3.00" (75mm)	4.00" (102mm)	115mm	45mm	25mm	Black	4	5mm
TS-HR325400-BE	3.25" (83mm)	4.00" (102mm)	115mm	45mm	25mm	Blue	4	5mm
TS-HR325400-BK	3.25" (83mm)	4.00" (102mm)	115mm	45mm	25mm	Black	4	5mm
TS-HR350375-BE	3.50" (89mm)	3.75" (95mm)	115mm	45mm	25mm	Blue	4	5mm
TS-HR350375-BK	3.50" (89mm)	3.75" (95mm)	115mm	45mm	25mm	Black	4	5mm
TS-HR350400-BE	3.50" (89mm)	4.00" (102mm)	115mm	45mm	25mm	Blue	4	5mm
TS-HR350400-BK	3.50" (89mm)	4.00" (102mm)	115mm	45mm	25mm	Black	4	5mm

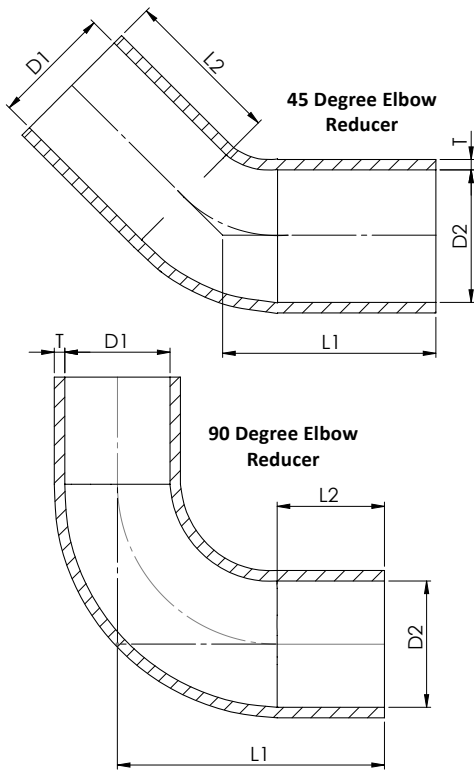

## 45 DEGREE ELBOW REDUCERS

Part Number	D1	D2	L1	L2	Colour	Ply	T
TS-HRE2025-BE <b>NEW</b>	2.00" (51mm)	2.50" (63mm)	80mm	100mm	Blue	4	5mm
TS-HRE2025-BK <b>NEW</b>	2.00" (51mm)	2.50" (63mm)	80mm	100mm	Black	4	5mm
TS-HRE42030-BE <b>NEW</b>	2.00" (51mm)	3.00" (76mm)	90mm	90mm	Blue	4	5mm
TS-HRE42030-BK <b>NEW</b>	2.00" (51mm)	3.00" (76mm)	90mm	90mm	Black	4	5mm
TS-HRE42225-BE	2.25" (57mm)	2.50" (63mm)	102mm	75mm	Blue	4	5mm
TS-HRE42225-BK	2.25" (57mm)	2.50" (63mm)	102mm	75mm	Black	4	5mm
TS-HRE4250275-BE <b>NEW</b>	2.50" (63mm)	2.75" (70mm)	75mm	85mm	Blue	4	5mm
TS-HRE4250275-BK <b>NEW</b>	2.50" (63mm)	2.75" (70mm)	75mm	85mm	Black	4	5mm
TS-HRE42530-BE <b>NEW</b>	2.50" (63mm)	3.00" (76mm)	85mm	95mm	Blue	4	5mm
TS-HRE42530-BK <b>NEW</b>	2.50" (63mm)	3.00" (76mm)	85mm	95mm	Black	4	5mm
TS-HRE4275300-BE <b>NEW</b>	2.75" (70mm)	3.00" (76mm)	80mm	95mm	Blue	4	5mm
TS-HRE4275300-BK <b>NEW</b>	2.75" (70mm)	3.00" (76mm)	80mm	95mm	Black	4	5mm

## 90 DEGREE ELBOW REDUCERS

Part Number	D1	D2	L1	L2	Colour	Ply	T
TS-HRE92025-BE	2.00" (50mm)	2.50" (60mm)	127mm	51mm	Blue	4	5mm
TS-HRE92025-BK	2.00" (50mm)	2.50" (60mm)	127mm	51mm	Black	4	5mm
TS-HRE92030-BE <b>NEW</b>	2.00" (50mm)	3.00" (76mm)	100mm	80mm	Blue	4	5mm
TS-HRE92030-BK <b>NEW</b>	2.00" (50mm)	3.00" (76mm)	100mm	80mm	Black	4	5mm
TS-HRE9250275-BE <b>NEW</b>	2.50" (63mm)	2.75" (70mm)	110mm	70mm	Blue	4	5mm
TS-HRE9250275-BK <b>NEW</b>	2.50" (63mm)	2.75" (70mm)	110mm	70mm	Black	4	5mm
TS-HRE92530-BE	2.50" (63mm)	3.00" (76mm)	127mm	51mm	Blue	4	5mm
TS-HRE92530-BK	2.50" (63mm)	3.00" (76mm)	127mm	51mm	Black	4	5mm
TS-HRE9275300-BE <b>NEW</b>	2.75" (70mm)	3.00" (76mm)	110mm	70mm	Blue	4	5mm
TS-HRE9275300-BK <b>NEW</b>	2.75" (70mm)	3.00" (76mm)	110mm	70mm	Black	4	5mm



45 and 90 Degree Elbow Reducers



## MURRAY TURBO SEAL SERIES CONSTANT TENSION CLAMPS

Turbosmart stocks and recommends Murray Corporation Turbo Seal Series Stainless Steel Specialty Worm Drive Clamps.

### CONSTANT TENSION CLAMPS (2 PER PACK)

Part Number	Diameter (inch)	Diameter (mm)
TS-HCT-M033	1.125-1.500"	(28-38mm)
TS-HCT-M042	1.375-1.875"	(35-48mm)
TS-HCT-M050	1.625-2.375"	(41-60mm)
TS-HCT-M062	1.970-2.875"	(50-73mm)
TS-HCT-M075	2.500-3.375"	(64-86mm)
TS-HCT-M081	2.750-3.625"	(70-92mm)
TS-HCT-M100	3.500-4.375"	(89-111mm)



### SPRING CLAMPS (10 PER PACK)

Part Number	Suits Vacuum Hose ID (inch)	(mm)
TS-HCS-003	0.12"	(3mm)
TS-HCS-005	0.20"	(5mm)
TS-HCS-006	0.24"	(6mm)



### HOSE BLANKING PLUGS

Part Number	Diameter (inch)	Diameter (mm)
TS-0205-2012	0.75"	(19mm)
TS-0205-2013	1.00"	(25mm)
TS-0205-2014	1.14"	(29mm)
TS-0205-2015	1.26"	(32mm)
TS-0205-2016	1.34"	(34mm)
TS-0205-2017	1.50"	(38mm)



BLOW-OFF VALVES  
WASTEGATES  
BOOST CONTROLLERS  
FUEL CUT DEFENDERS  
GAUGES/BRAS  
FUEL PRESSURE REGULATORS  
FUEL RAIL ADAPTERS  
FUEL FILTERS/OPRS  
SILICONE HOSE  
PRODUCT FITMENT GUIDE

# MAKE/MODEL PRODUCT FITMENT GUIDE



Model	Year	BOV Part No.	BOV Description	IWG Part No.	IWG Description	BRA Part No.	BRA Description
A3 1.8T 20v	1996-2003	TS-0203-1222	Kompact Plumb Back - 25mm				
		TS-0203-1022	Kompact Dual Port - 25mm				
A3 1.8 TFSI	2004-current	TS-0203-1241	Kompact VAG 2.0T V2 Plumb Back			TS-0720-1002	Black
		TS-0203-1041	Kompact VAG 2.0T V2 Dual Port				
A3 2.0 TFSI	2004-2013	TS-0203-1241	Kompact VAG 2.0T V2 Plumb Back	TS-0645-2052	IWG75 VAG K03 Variant 5PSI - Black	TS-0720-1002	Black
		TS-0203-1041	Kompact VAG 2.0T V2 Dual Port	TS-0645-4102	IWG75 VAG K03 Variant 10PSI - Black		
A3 2.0 TSI	2013-current	TS-0203-1263	Kompact Shortie - EVR05 Plumb Back			TS-0720-1010	Black
		TS-0203-1063	Kompact Shortie - EVR05 Dual Port				
A4 1.8T 20v	1997-2006	TS-0203-1222	Kompact Plumb Back - 25mm				
		TS-0203-1022	Kompact Dual Port - 25mm				
A4 1.8 TFSI	2004-current	TS-0203-1241	Kompact VAG 2.0T V2 Plumb Back			TS-0720-1002	Black
		TS-0203-1041	Kompact VAG 2.0T V2 Dual Port				
A4 2.0 TFSI	2004-current	TS-0203-1241	Kompact VAG 2.0T V2 Plumb Back	TS-0645-2052	IWG75 VAG K03 Variant 5PSI - Black	TS-0720-1002	Black
		TS-0203-1041	Kompact VAG 2.0T V2 Dual Port	TS-0645-4102	IWG75 VAG K03 Variant 10PSI - Black		
A5 2.0 TFSI	2008-2015	TS-0203-1241	Kompact VAG 2.0T V2 Plumb Back	TS-0645-2052	IWG75 VAG K03 Variant 5PSI - Black	TS-0720-1002	Black
		TS-0203-1041	Kompact VAG 2.0T V2 Dual Port	TS-0645-4102	IWG75 VAG K03 Variant 10PSI - Black		
A6 1.8T 20v	1997-2004	TS-0203-1222	Kompact Plumb Back - 25mm				
		TS-0203-1022	Kompact Dual Port - 25mm				
A6 2.0 TFSI	2004-2014	TS-0203-1241	Kompact VAG 2.0T V2 Plumb Back			TS-0720-1002	Black
		TS-0203-1041	Kompact VAG 2.0T V2 Dual Port				
A6 2.0 TFSI	2015-current	TS-0203-1263	Kompact Shortie - EVR05 Plumb Back			TS-0720-1010	Black
		TS-0203-1063	Kompact Shortie - EVR05 Dual Port				
A7 2.0 TFSI	2015-current	TS-0203-1263	Kompact Shortie - EVR05 Plumb Back				
		TS-0203-1063	Kompact Shortie - EVR05 Dual Port				
A8 2.0 TFSI	2010-2015	TS-0203-1241	Kompact VAG 2.0T V2 Plumb Back			TS-0720-1002	Black
		TS-0203-1041	Kompact VAG 2.0T V2 Dual Port				
S3 1.8T 20v	1999-2003	TS-0203-1222	Kompact Plumb Back - 25mm				
		TS-0203-1022	Kompact Dual Port - 25mm				
S3 2.0T	2006-2013	TS-0203-1241	Kompact VAG 2.0T V2 Plumb Back	TS-0645-1052	IWG75 VAG K04 Variant 5PSI - Black	TS-0720-1002	Black
		TS-0203-1041	Kompact VAG 2.0T V2 Dual Port	TS-0645-3102	IWG75 VAG K04 Variant 10PSI - Black		
		TS-0215-1041	Smart Port 2.0L VAG Golf R/S3 BOV - Black				
S3 2.0T	2013-current	TS-0203-1263	Kompact Shortie - EVR05 Plumb Back			TS-0720-1010	Black
		TS-0203-1063	Kompact Shortie - EVR05 Dual Port				
S4 2.0T	2005-2015	TS-0203-1241	Kompact VAG 2.0T V2 Plumb Back	TS-0645-1052	IWG75 VAG K04 Variant 5PSI - Black	TS-0720-1002	Black
		TS-0203-1041	Kompact VAG 2.0T V2 Dual Port	TS-0645-3102	IWG75 VAG K04 Variant 10PSI - Black		
		TS-0215-1041	Smart Port 2.0L VAG Golf R/S3 BOV - Black				
S5 2.0T	2008-2015	TS-0203-1241	Kompact VAG 2.0T V2 Plumb Back	TS-0645-1052	IWG75 VAG K04 Variant 5PSI - Black	TS-0720-1002	Black
		TS-0203-1041	Kompact VAG 2.0T V2 Dual Port	TS-0645-3102	IWG75 VAG K04 Variant 10PSI - Black		
		TS-0215-1041	Smart Port 2.0L VAG Golf R/S3 BOV - Black				
TT 1.8T 20v	1998-2006	TS-0203-1222	Kompact Plumb Back - 25mm				
		TS-0203-1022	Kompact Dual Port - 25mm				
TT 2.0 TFSI	2006-2014	TS-0203-1241	Kompact VAG 2.0T V2 Plumb Back	TS-0645-2052	IWG75 VAG K03 Variant 5PSI - Black	TS-0720-1002	Black
		TS-0203-1041	Kompact VAG 2.0T V2 Dual Port	TS-0645-4102	IWG75 VAG K03 Variant 10PSI - Black		
TTS 2.0 TFSI	2006-2014	TS-0203-1241	Kompact VAG 2.0T V2 Plumb Back	TS-0645-1052	IWG75 VAG K04 Variant 5PSI - Black	TS-0720-1002	Black
		TS-0203-1041	Kompact VAG 2.0T V2 Dual Port	TS-0645-3102	IWG75 VAG K04 Variant 10PSI - Black		
		TS-0215-1041	Smart Port 2.0L VAG Golf R/S3 BOV - Black				
TT 2.0 TSI	2015-current	TS-0203-1263	Kompact Shortie - EVR05 Plumb Back			TS-0720-1010	Black
		TS-0203-1063	Kompact Shortie - EVR05 Dual Port				



**Audi Fitment Guide Continued.**

Model	Year	BOV Part No.	BOV Description	IWG Part No.	IWG Description	BRA Part No.	BRA Description
Q3 2.0 TFSI	2012-2014	TS-0203-1241	Kompact VAG 2.0T V2 Plumb Back	TS-0645-2052	IWG75 VAG K03 Variant 5PSI - Black	TS-0720-1002	Black
		TS-0203-1041	Kompact VAG 2.0T V2 Dual Port	TS-0645-4102	IWG75 VAG K03 Variant 10PSI - Black		
Q3 2.0 TSI	2015-current	TS-0203-1263	Kompact Shortie - EVR05 Plumb Back			TS-0720-1010	Black
		TS-0203-1063	Kompact Shortie - EVR05 Dual Port				
Q5 2.0 TFSI	2009-current	TS-0203-1241	Kompact VAG 2.0T V2 Plumb Back	TS-0645-2052	IWG75 VAG K03 Variant 5PSI - Black		
		TS-0203-1041	Kompact VAG 2.0T V2 Dual Port	TS-0645-4102	IWG75 VAG K03 Variant 10PSI - Black		
Q7 2.0 TSI	2016-current	TS-0203-1263	Kompact Shortie - EVR05 Plumb Back			TS-0720-1010	Black
		TS-0203-1063	Kompact Shortie - EVR05 Dual Port				
A1 Quattro 2.0 TSI	2012-current	TS-0203-1241	Kompact VAG 2.0T V2 Plumb Back	TS-0645-1052	IWG75 VAG K04 Variant 5PSI - Black	TS-0720-1002	Black
		TS-0203-1041	Kompact VAG 2.0T V2 Dual Port	TS-0645-3102	IWG75 VAG K04 Variant 10PSI - Black		
		TS-0215-1041	Smart Port 2.0L VAG Golf R/S3 BOV - Black				



Model	Year	BOV Part No.	BOV Description	BOV Adapters/Kits
GT Continental	2003-current	TS-0203-1222	Kompact Plumb Back-25mm	Requires 2 Valves
		TS-0203-1022	Kompact Dual Port-25mm	Requires 2 Valves



Model	Year	BOV Part No.	BOV Description	BOV Adapters/Kits Part No. & Description
135i N54	2008-2010	TS-0203-1250	Kompact Plumb Back KIT - BMW	
		TS-0203-1050	Kompact Dual Port KIT - BMW	
335i N54	2007-2011	TS-0203-1250	Kompact Plumb Back KIT - BMW	
		TS-0203-1050	Kompact Dual Port KIT - BMW	
Z4 N54	2010-current	TS-0203-1250	Kompact Plumb Back KIT - BMW	TS-0203-2001 BOV Kompact Z4 additional pipe
		TS-0203-1050	Kompact Dual Port KIT - BMW	TS-0203-2001 BOV Kompact Z4 additional pipe



Model	Year	BOV Part No.	BOV Description
ATS-V	2015-current	TS-0203-1008	Kompact Dual Port Kit



Model	Year	BOV Part No.	BOV Description	IWG Part No.	IWG Description
Ram 5.9L Diesel	2000-2004			TS-0626-1262	IWG75 Dodge Ram 5.9L TD 26psi
Stealth	1991-1996	TS-0203-1223	Kompact Plumb Back - 34mm		
		TS-0203-1023	Kompact Dual Port - 34mm		
		TS-0205-1020	Dual Port Mitsubishi - Red		
		TS-0205-1021	Dual Port Mitsubishi - Black		

BLOW-OFF VALVES  
WASTEGATES  
BOOST CONTROLLERS  
FUEL CUT DEFENDERS  
GAUGES/BRAS  
FUEL PRESSURE REGULATORS  
FUEL RAIL ADAPTERS  
FUEL FILTERS/OPRS  
SILICONE HOSE  
PRODUCT FITMENT GUIDE

# MAKE/MODEL PRODUCT FITMENT GUIDE



Model	Year	BOV Part No.	BOV Description
Coupe 16 20V	1993-2000	TS-0203-1222	Kompact Plumb Back - 25mm
		TS-0203-1022	Kompact Dual Port - 25mm
Punto GT	1993-1999	TS-0203-1222	Kompact Plumb Back - 25mm
		TS-0203-1022	Kompact Dual Port - 25mm
Uno Mk1	1985-1989	TS-0203-1222	Kompact Plumb Back - 25mm
		TS-0203-1022	Kompact Dual Port - 25mm
Uno Mk2	1989-1995	TS-0203-1222	Kompact Plumb Back - 25mm
		TS-0203-1022	Kompact Dual Port - 25mm



Model	Year	BOV Part No.	BOV Description	IWG Part No.	IWG Description	BRA Part No.	BRA Description
C-Max EcoBoost 1.6L	2010-current	TS-0203-1059	Kompact Shortie VR10 - Dual Port			TS-0720-1003	Black
		TS-0203-1259	Kompact Shortie VR10 - Plumb Back				
Edge Sport EcoBoost 2.7L	2015-current	TS-0203-1081	Kompact Shortie Dual Port - Ford Mustang 2015+ EcoBoost			TS-0720-1004	Black
		TS-0203-1281	Kompact Shortie Plumb Back Ford Mustang 2.3L EcoBoost				
F150 3.5 EcoBoost	2011-2012	TS-0203-1261	Kompact Shortie - Plumb Back	TS-0622-4052	IWG75 Ford F150 EcoBoost 5PSI - Black		
		TS-0203-1061	Kompact Shortie - Dual Port				
F150 3.5 EcoBoost	2013-current	TS-0215-1367	Ford F150 2012+ EcoBoost Smart Port Supersonic BOV - Black			TS-0720-1005	Black
F150 2.7 EcoBoost	2015-current					TS-0720-1004	Black
Falcon XR6 BA Turbo	2002-2005	TS-0203-1222	Kompact Plumb Back - 25mm	TS-0622-1052	IWG75 Ford XR6 Actuator 5PSI		
		TS-0203-1022	Kompact Dual Port - 25mm	TS-0622-1072	IWG75 Ford XR6 Actuator 7PSI		
				TS-0622-1122	IWG75 Ford XR6 Actuator 12PSI		
Falcon XR6 BF Turbo	2005-2008	TS-0203-1222	Kompact Plumb Back - 25mm	TS-0622-1052	IWG75 Ford XR6 Actuator 5PSI		
		TS-0203-1022	Kompact Dual Port - 25mm	TS-0622-1072	IWG75 Ford XR6 Actuator 7PSI		
				TS-0622-1122	IWG75 Ford XR6 Actuator 12PSI		
Falcon XR6 FG Turbo	2008-2014	TS-0203-1222	Kompact Plumb Back - 25mm	TS-0622-1052	IWG75 Ford XR6 Actuator 5PSI		
		TS-0203-1022	Kompact Dual Port - 25mm	TS-0622-1072	IWG75 Ford XR6 Actuator 7PSI		
				TS-0622-1122	IWG75 Ford XR6 Actuator 12PSI		
Falcon EcoBoost FG 2.0L	2012-current	TS-0203-1261	Kompact Shortie - Plumb Back				
		TS-0203-1061	Kompact Shortie - Dual Port				
Fiesta ST 1.6L EcoBoost	2009-current	TS-0203-1066	Kompact Shortie Dual Port - Ford Fiesta ST 1.6L	TS-0622-7072	IWG75 Ford Fiesta ST 1.6L EcoBoost 7PSI - Black	TS-0720-1003	Black
		TS-0203-1266	Ford Fiesta 1.6L EcoBoost Kompact Shortie Plumb Back				
Fiesta ST 1.0L EcoBoost	2013-current	TS-0203-1065	Kompact Dual Port Shortie Ford 1L EcoBoost				
		TS-0203-1265	Kompact Plumb Back Shortie Ford 1L EcoBoost				
Focus Mk1 RS 2.0T	2002-2003	TS-0203-1261	Kompact Shortie - Plumb Back	TS-0622-3072	IWG75 Ford Focus Mk1 RS 2.0T 7PSI		
		TS-0203-1061	Kompact Shortie - Dual Port				
Focus Mk2 XRS/RS/ST 2.5 5 cyl	2005-2010	TS-0203-1261	Kompact Shortie - Plumb Back	TS-0622-2072	IWG75 Ford Focus ST/XRS/RS 2.5L Turbo 7PSI		
		TS-0203-1061	Kompact Shortie - Dual Port				



**Ford Fitment Guide Continued.**

Model	Year	BOV Part No.	BOV Description	IWG Part No.	IWG Description	BRA Part No.	BRA Description
Focus Mk3 RS 2.3 EcoBoost	2016-current	TS-0203-1264	Kompact Shortie VR08 - Plumb Back	TS-0622-9122	IWG75 Ford Focus RS 2.3 EcoBoost 12PSI		
		TS-0203-1064	Kompact Shortie VR08 - Dual Port				
Focus Mk3 ST 2.0 EcoBoost	2012-current	TS-0203-1261	Kompact Shortie - Plumb Back	TS-0622-5072	IWG75 Ford Focus ST 2.0L EcoBoost 7PSI		
		TS-0203-1061	Kompact Shortie - Dual Port				
Focus EcoBoost 1.6L	2010-2014	TS-0203-1059	Kompact Shortie VR10 - Dual Port			TS-0720-1003	Black
		TS-0203-1259	Kompact Shortie VR10 - Plumb Back				
Fusion 1.6L EcoBoost	2013-current	TS-0203-1066	Kompact Shortie Dual Port - Ford Fiesta ST 1.6L				
		TS-0203-1266	Kompact Shortie Plumb Back - Ford Fiesta ST 1.6L				
Galaxy EcoBoost 1.6L	2010-2014	TS-0203-1059	Kompact Shortie VR10 - Dual Port			TS-0720-1003	Black
		TS-0203-1259	Kompact Shortie VR10 - Plumb Back				
Galaxy EcoBoost 2.0L	2010-current	TS-0203-1061	Kompact Shortie - Dual Port				
		TS-0203-1261	Kompact Shortie - Plumb Back				
Kuga Duratec 2.5T	2008-2012	TS-0203-1261	Kompact Shortie - Plumb Back	TS-0622-2072	IWG75 Ford Focus ST/XR5 2.5L Turbo 7PSI		
		TS-0203-1061	Kompact Shortie - Dual Port				
Kuga EcoBoost 2.0L	2013-current	TS-0203-1059	Kompact Shortie VR10 - Dual Port	TS-0622-5072	IWG75 Ford Focus ST 2.0L EcoBoost 7PSI		
		TS-0203-1259	Kompact Shortie VR10 - Plumb Back				
Kuga EcoBoost 1.6L	2013-2014	TS-0203-1061	Kompact Shortie Dual Port			TS-0720-1003	Black
		TS-0203-1261	Kompact Shortie Plumb Back				
Mondeo EcoBoost 1.6L	2010-current	TS-0203-1059	Kompact Shortie VR10 - Dual Port	TS-0622-7072	IWG75 Ford Fiesta ST 1.6L EcoBoost 7PSI - Black	TS-0720-1003	Black
		TS-0203-1259	Kompact Shortie VR10 - Plumb Back				
Mondeo EcoBoost 2.0L	2010-current	TS-0203-1261	Kompact Shortie - Plumb Back				
		TS-0203-1061	Kompact Shortie - Dual Port				
Mustang EcoBoost	2015-current	TS-0203-1081	Kompact Shortie Dual Port - Ford Mustang 2015+ EcoBoost	TS-0622-8072	IWG75 2015 Ford Mustang 2.3L EcoBoost 7PSI	TS-0720-1004	Black
		TS-0203-1281	Kompact Shortie Plumb Back Ford Mustang 2.3L EcoBoost	TS-0622-8102	IWG75 2015 Ford Mustang 2.3L EcoBoost 10PSI		
				TS-0622-8122	IWG75 2015 Ford Mustang 2.3L EcoBoost 12 PSI		
Powerstroke 7.3L	1994-2005			TS-0622-6212	IWG75 Ford Powerstroke 7.3L 21PSI		
Ranger 3.2TD	2011-current					TS-0720-1001	Black
S-Max EcoBoost 1.6L	2010-current	TS-0203-1059	Kompact Shortie VR10 - Dual Port			TS-0720-1003	Black
		TS-0203-1259	Kompact Shortie VR10 - Plumb Back				
S-Max EcoBoost 2.0L	2010-current	TS-0203-1261	Kompact Shortie - Plumb Back				
		TS-0203-1061	Kompact Shortie - Dual Port				
Sierra Cosworth 2WD & 4WD	1986-1992	TS-0203-1222	Kompact Plumb Back-25mm				
		TS-0203-1022	Kompact Dual Port-25mm				
Territory Turbo	2006-2010	TS-0203-1222	Kompact Plumb Back-25mm	TS-0622-1052	IWG75 Ford XR6 Actuator 5PSI		
		TS-0203-1022	Kompact Dual Port-25mm	TS-0622-1072	IWG75 Ford XR6 Actuator 7PSI		
				TS-0622-1122	IWG75 Ford XR6 Actuator 12PSI		

# MAKE/MODEL PRODUCT FITMENT GUIDE



Model	Year	BOV Part No.	BOV Description
Veloster Turbo	2011-current	TS-0203-1031	Kompact Shortie - VR02 Dual Port
		TS-0203-1231	Kompact Shortie - Plumb Back



Model	Year	BOV Part No.	BOV Description
1.6L Delta HF	1979-1994	TS-0203-1222	Kompact Plumb Back - 25mm
		TS-0203-1022	Kompact Dual Port - 25mm
2.0L Delta Integrale 8 16V	1989-1994	TS-0203-1222	Kompact Plumb Back - 25mm
		TS-0203-1022	Kompact Dual Port - 25mm



Model	Year	IWG Part No.	IWG Description
TD5	1988-2007	TS-0628-1171	IWG75 Landrover TD5 17psi - Black



Model	Year	BOV Part No.	BOV Description	IWG Part No.	IWG Description <small>NOTE: RHD Variant Only</small>	BRA Part No.	BRA Description
CX7 2.3L Turbo	2006-2012	TS-0203-1209	Kompact Plumb Back - Mazda	TS-0610-1072	IWG75 Mazda MPS 7PSI - Black		
		TS-0203-1009	Kompact Dual Port - Mazda	TS-0610-1182	IWG75 Mazda MPS 18PSI - Black		
		TS-0205-1309	Supersonic Mazda/Subaru - Blue	TS-0610-1222	IWG75 Mazda MPS 22PSI - Black		
		TS-0205-1310	Supersonic Mazda/Subaru - Black	TS-0610-1242	IWG75 Mazda MPS 24PSI - Black		
		TS-0205-1009	Dual Port Mazda/Subaru- Blue				
Mazdaspeed (MPS) 3 (BK series)	2007-2009	TS-0203-1209	Kompact Plumb Back - Mazda	TS-0610-1072	IWG75 Mazda MPS 7PSI - Black		
		TS-0203-1009	Kompact Dual Port - Mazda	TS-0610-1182	IWG75 Mazda MPS 18PSI - Black		
		TS-0205-1309	Supersonic Mazda/Subaru - Blue	TS-0610-1222	IWG75 Mazda MPS 22PSI - Black		
		TS-0205-1310	Supersonic Mazda/Subaru - Black	TS-0610-1242	IWG75 Mazda MPS 24PSI - Black		
		TS-0205-1009	Dual Port Mazda/Subaru- Blue				
Mazdaspeed (MPS) 3 (BL series)	2010-2013	TS-0203-1209	Kompact Plumb Back - Mazda	TS-0610-1072	IWG75 Mazda MPS 7PSI - Black		
		TS-0203-1009	Kompact Dual Port - Mazda	TS-0610-1182	IWG75 Mazda MPS 18PSI - Black		
		TS-0205-1309	Supersonic Mazda/Subaru - Blue	TS-0610-1222	IWG75 Mazda MPS 22PSI - Black		
		TS-0205-1310	Supersonic Mazda/Subaru - Black	TS-0610-1242	IWG75 Mazda MPS 24PSI - Black		
		TS-0205-1010	Dual Port Mazda/Subaru- Black				
Mazdaspeed (MPS) 6	2005-2007	TS-0203-1209	Kompact Plumb Back - Mazda	TS-0610-1072	IWG75 Mazda MPS 7PSI - Black		
		TS-0203-1009	Kompact Dual Port - Mazda	TS-0610-1182	IWG75 Mazda MPS 18PSI - Black		
		TS-0205-1309	Supersonic Mazda/Subaru - Blue	TS-0610-1222	IWG75 Mazda MPS 22PSI - Black		
		TS-0205-1310	Supersonic Mazda/Subaru - Black	TS-0610-1242	IWG75 Mazda MPS 24PSI - Black		
		TS-0205-1009	Dual Port Mazda/Subaru- Blue				

BLOW-OFF VALVES  
WASTEGATES  
BOOST CONTROLLERS  
FUEL CUT DEFENDERS  
GAUGES/BRAS  
FUEL PRESSURE REGULATORS  
FUEL RAIL ADAPTERS  
FUEL FILTERS/OPRS  
SILICONE HOSE  
PRODUCT FITMENT GUIDE

**Mazda Fitment Guide Continued.**

Model	Year	BOV Part No.	BOV Description	IWG Part No.	IWG Description <i>NOTE: RHD Variant Only</i>	BRA Part No.	BRA Description
		TS-0205-1010	Dual Port Mazda/Subaru- Black				
MX5 SP & SE	2004-2005	TS-0203-1222	Kompact Plumb Back - 25mm				
		TS-0203-1022	Kompact Dual Port - 25mm				
BT-50	2011-current					TS-0720-1001	Black



Model	Year	BOV Part No.	BOV Description
A45 AMG	2013-current	TS-0203-1062	Kompact Shortie - VR03 Dual Port
		TS-0203-1262	Kompact Shortie - VR03 Plumb Back
C63 AMG (W205)	2014-current	TS-0203-1067	Kompact Shortie - Dual Port
		TS-0203-1267	Kompact Shortie - Plumb Back



Model	Year	BOV Part No.	BOV Description	BRA Part No.	BRA Description
Cooper R56 Turbo	2006-2013	TS-0203-1052	Kompact Shortie - EVR06 Dual Port	TS-0720-1006	Black
		TS-0203-1252	Kompact Shortie - EVR06 Plumb Back		



Model	Year	BOV Part No.	BOV Description	IWG Part No.	IWG Description
Lancer EVO 4-8	1996-2005	TS-0203-1223	Kompact Plumb Back - 34mm	TS-0601-1102	IWG75 Mitsubishi EVO 6-8 10PSI - Black
		TS-0203-1023	Kompact Dual Port - 34mm	TS-0601-1142	IWG75 Mitsubishi EVO 6-8 14PSI - Black
		TS-0205-1020	Dual Port Mitsubishi - Red	TS-0601-1182	IWG75 Mitsubishi EVO 6-8 18PSI - Black
		TS-0205-1021	Dual Port Mitsubishi - Black	TS-0601-1222	IWG75 Mitsubishi EVO 6-8 22PSI - Black
		TS-0215-1022	Smart Port Dual Port Mitsubishi Evo IV to X - Red	TS-0601-1242	IWG75 Mitsubishi EVO 6-8 24PSI - Black
		TS-0215-1023	Smart Port Dual Port Mitsubishi Evo IV to X - Black		
Lancer EVO 9	2005-2007	TS-0203-1223	Kompact Plumb Back - 34mm	TS-0601-2102	IWG75 Mitsubishi EVO 9 10PSI - Black
		TS-0203-1023	Kompact Dual Port - 34mm	TS-0601-2142	IWG75 Mitsubishi EVO 9 14PSI - Black
		TS-0205-1020	Dual Port Mitsubishi - Red	TS-0601-2182	IWG75 Mitsubishi EVO 9 18PSI - Black
		TS-0205-1021	Dual Port Mitsubishi - Black	TS-0601-2222	IWG75 Mitsubishi EVO 9 22PSI - Black
		TS-0215-1022	Smart Port Dual Port Mitsubishi Evo IV to X - Red	TS-0601-2242	IWG75 Mitsubishi EVO 9 24PSI - Black
		TS-0215-1023	Smart Port Dual Port Mitsubishi Evo IV to X - Black	TS-0601-2262	IWG75 Mitsubishi EVO 9 26PSI - Black
Lancer EVO X	2007-2015	TS-0203-1223	Kompact Plumb Back - 34mm	TS-0601-3102	IWG75 Mitsubishi EVO 10 10PSI - Black
		TS-0203-1023	Kompact Dual Port - 34mm	TS-0601-3122	IWG75 Mitsubishi EVO 10 12PSI - Black
		TS-0205-1022	Dual Port Mitsubishi EVO X BOV - Red	TS-0601-3142	IWG75 Mitsubishi EVO 10 14PSI - Black
		TS-0205-1023	Dual Port Mitsubishi EVO X - Black	TS-0601-3182	IWG75 Mitsubishi EVO 10 18PSI - Black
		TS-0215-1022	Smart Port Dual Port Mitsubishi Evo IV to X - Red	TS-0601-3222	IWG75 Mitsubishi EVO 10 22PSI - Black
		TS-0215-1023	Smart Port Dual Port Mitsubishi Evo IV to X - Black	TS-0601-3242	IWG75 Mitsubishi EVO 10 24PSI - Black
Ralliart Colt	2006-2010	TS-0203-1223	Kompact Plumb Back - 34mm		
		TS-0203-1023	Kompact Dual Port - 34mm		
		TS-0205-1020	Dual Port Mitsubishi - Red		
		TS-0205-1021	Dual Port Mitsubishi - Black		
GTO/3000GT	1990-2001	TS-0203-1223	Kompact Plumb Back - 34mm		
		TS-0203-1023	Kompact Dual Port - 34mm		
		TS-0205-1020	Dual Port Mitsubishi - Red		
		TS-0205-1021	Dual Port Mitsubishi - Black		

# MAKE/MODEL PRODUCT FITMENT GUIDE



Model	Year	BOV Part No.	BOV Description	BOV Adapters/Kits Part No. & Description	IWG Part No.	IWG Description	BRA Part No.	BRA Description
Juke MR16DDT 1.6L Turbo	2011-current	TS-0203-1210	Kompact Plumb Back - Subaru/Nissan		TS-0615-3072	IWG75 Nissan Pulsar SSS/ Juke 7PSI		
		TS-0203-1010	Kompact Dual Port - Subaru/ Nissan		TS-0615-3142	IWG75 Nissan Pulsar SSS/ Juke 14PSI		
		TS-0205-1140	Vee Port Pro Nissan Juke/ Pulsar - Blue					
		TS-0205-1141	Vee Port Pro Nissan Juke/ Pulsar - Black					
Pulsar MR16DDT 1.6L Turbo	2013-current	TS-0203-1210	Kompact Plumb Back - Subaru/Nissan		TS-0615-3072	IWG75 Nissan Pulsar SSS/ Juke 7PSI		
		TS-0203-1010	Kompact Dual Port - Subaru/ Nissan		TS-0615-3142	IWG75 Nissan Pulsar SSS/ Juke 14PSI		
		TS-0205-1140	Vee Port Pro Nissan Juke/ Pulsar - Blue					
		TS-0205-1141	BOV Vee Port Pro Nissan Juke/Pulsar - Black					
Skyline R32 GT-R RB26DETT	1988-1994	TS-0205-1026	Dual Port Nissan-Black	Requires 2 BOV Kits				
Skyline R33 GT-R RB26DETT	1993-1998	TS-0205-1026	Dual Port Nissan-Black	Requires 2 BOV Kits				
Skyline R34 GT-R RB26DETT	1999-2002	TS-0205-1026	Dual Port Nissan-Black	Requires 2 BOV Kits				
Skyline R32 GTS-T RB20DET	1988-1994	TS-0205-1300	Supersonic Universal Fit - Blue	TS-0205-2052 - BOV Nissan R32 Adapter Kit				
		TS-0205-1301	Supersonic Universal Fit - Black	TS-0205-2052 - BOV Nissan R32 Adapter Kit				
		TS-0205-1130	Vee Port Pro - Blue	TS-0205-2057 - BOV Nissan Flange Adapter Kit				
		TS-0205-1131	Vee Port Pro - Black	TS-0205-2057 - BOV Nissan Flange Adapter Kit				
		TS-0203-1226	Kompact Plumb Back - Nissan					
		TS-0203-1026	Kompact Dual Port - Nissan					
Skyline R33 GTS-T RB25DET	1993-1998	TS-0205-1026	Dual Port Nissan-Black					
		TS-0203-1226	Kompact Plumb Back - Nissan					
		TS-0203-1026	Kompact Dual Port - Nissan					
Skyline R34 GTS-T RB25DET	1999-2002	TS-0205-1026	Dual Port Nissan-Black					
		TS-0203-1226	Kompact Plumb Back - Nissan					
		TS-0203-1026	Kompact Dual Port - Nissan					
R35 GT-R VR38DETT	2007-current	TS-0205-1027	Dual Port Nissan GTR Kit-Black		TS-0615-2072	IWG75 Nissan GTR R35 7PSI - Black		
		TS-0215-1027	Smart Port Dual Port Nissan GT-R R35 Kit		TS-0615-2242	IWG75 Nissan GTR R35 24PSI - Black		
					TS-0615-2073	IWG75 Nissan GTR R35 Twin Port 7PSI - Black		
Stagea Turbo	1996-2001	TS-0205-1026	Dual Port Nissan-Black	RB26DETT Requires 2 BOV Kits				
		TS-0203-1226	Kompact Plumb Back - Nissan	RB25DET Only				
		TS-0203-1026	Kompact Dual Port - Nissan					
Stagea Turbo	2001-2007	TS-0203-1226	Kompact Plumb Back - Nissan					
		TS-0203-1026	Kompact Dual Port - Nissan					
Patrol Y61 ZD30	1997-2013				TS-0615-4072	IWG75 Nissan Patrol ZD30 VNT 7PSI - Black	TS-0720-1008	Black
Patrol Y61 TD42	1997-2013				TS-0615-5072	IWG75 Nissan Patrol TD42T 7PSI - Black	TS-0720-1008	Black



Model	Year	BOV Part No.	BOV Description
406 Sri	1997-1999	TS-0203-1222	Kompact Plumb Back-25mm
		TS-0203-1022	Kompact Dual Port-25mm
605 Sri	1991-1999	TS-0203-1222	Kompact Plumb Back-25mm
		TS-0203-1022	Kompact Dual Port-25mm



Model	Year	BOV Part No.	BOV Description	BOV Adapters/Kits Part No. & Description	IWG Part No.	IWG Description
911 (964)	1990-1994	TS-0203-1222	Kompact Plumb Back-25mm			
		TS-0203-1022	Kompact Dual Port-25mm			
911 GT2 (997)	2008-2012	TS-0203-1261	Kompact Shortie - Plumb Back	Requires 2 Valves	TS-0624-2072	IWG75 Porsche 996 911 GT2 7PSI - Black
		TS-0203-1061	Kompact Shortie - Dual Port	Requires 2 Valves	TS-0624-2242	IWG75 Porsche 996 911 GT2 24PSI - Black
911 Turbo (993)	1995-1998	TS-0203-1222	Kompact Plumb Back-25mm		TS-0624-1072	IWG75 Porsche 993 911 Turbo 7PSI - Black
		TS-0203-1022	Kompact Dual Port-25mm		TS-0624-1242	IWG75 Porsche 993 911 Turbo 24PSI - Black
911 Turbo (996)	1999-2005	TS-0203-1222	Kompact Plumb Back-25mm		TS-0624-3072	IWG75 Porsche 996 911 Turbo 7PSI - Black
		TS-0203-1022	Kompact Dual Port-25mm		TS-0624-3242	IWG75 Porsche 996 911 Turbo 24PSI - Black
911 Turbo (997)	2006-2013	TS-0203-1261	Kompact Shortie - Plumb Back	Requires 2 Valves		
		TS-0203-1061	Kompact Shortie - Dual Port	Requires 2 Valves		
944	1985-1991	TS-0203-1222	Kompact Plumb Back-25mm			
		TS-0203-1022	Kompact Dual Port-25mm			
Cayenne Turbo	2006-current	TS-0203-1222	Kompact Plumb Back-25mm	Requires 2 BOVs		
		TS-0203-1022	Kompact Dual Port-25mm	Requires 2 BOVs		



Model	Year	BOV Part No.	BOV Description	IWG Part No.	IWG Description	BRA Part No.	BRA Description
Clio RS	2012-current	TS-0203-1257	Kompact Shortie - EVR07 Plumb Back	TS-0623-1072	IWG75 Renault Clio RS 1.6T 7PSI	TS-0720-1006	Black
		TS-0203-1057	Kompact Shortie - EVR07 Dual Port				
Megane RS250		TS-0203-1057	Kompact Shortie - EVR07 Dual Port	TS-0646-1072	IWG75 Renault Megane RS250 7PSI		



Model	Year	BOV Part No.	BOV Description
900 Turbo	1979-1993	TS-0203-1222	Kompact Plumb Back - 25mm
		TS-0203-1022	Kompact Dual Port - 25mm
9000	1990-1998	TS-0203-1222	Kompact Plumb Back - 25mm
		TS-0203-1022	Kompact Dual Port - 25mm
93	1999-current	TS-0203-1222	Kompact Plumb Back - 25mm
		TS-0203-1022	Kompact Dual Port - 25mm
95	1997-2012	TS-0203-1222	Kompact Plumb Back - 25mm
		TS-0203-1022	Kompact Dual Port - 25mm

# MAKE/MODEL PRODUCT FITMENT GUIDE



Model	Year	BOV Part No.	BOV Description	IWG Part No.	IWG Description	BRA Part No.	BRA Description
Leon 2.0 TFSI	2006-2013	TS-0203-1241	Kompact VAG 2.0T V2 - Plumb Back	TS-0645-2052	IWG75 VAG K03 Variant 5PSI - Black	TS-0720-1002	Black
		TS-0203-1041	Kompact VAG 2.0T V2 - Dual Port	TS-0645-4102	IWG75 VAG K03 Variant 10PSI - Black		
Leon Cupra 2.0 R	2005-current	TS-0215-1041	Kompact VAG 2.0T V2 - Dual Port	TS-0645-1052	IWG75 VAG K04 Variant 5PSI - Black		
Leon 1.8 TFSI	2011-2013	TS-0203-1241	Kompact VAG 2.0T V2 - Plumb Back			TS-0720-1002	Black
		TS-0203-1041	Kompact VAG 2.0T V2 - Dual Port				
Leon 2.0 TSI	2014-current	TS-0203-1263	Kompact Shortie - EVR05 Plumb Back			TS-0720-1010	Black
		TS-0203-1063	Kompact Shortie - EVR05 Dual Port				
Alhambra 1.8/2.0 TFSI	2011-2015	TS-0203-1241	Kompact VAG 2.0T V2 - Plumb Back	TS-0645-2052	IWG75 VAG K03 Variant 5PSI - Black	TS-0720-1002	Black
		TS-0203-1041	Kompact VAG 2.0T V2 - Dual Port	TS-0645-4102	IWG75 VAG K03 Variant 10PSI - Black		
Alhambra 2.0 TSI	2016-current	TS-0203-1263	Kompact Shortie - EVR05 Plumb Back			TS-0720-1010	Black
		TS-0203-1063	Kompact Shortie - EVR05 Dual Port				
Altea 2.0 TFSI	2004-2015	TS-0203-1241	Kompact VAG 2.0T V2 - Plumb Back	TS-0645-2052	IWG75 VAG K03 Variant 5PSI - Black	TS-0720-1002	Black
		TS-0203-1041	Kompact VAG 2.0T V2 - Dual Port	TS-0645-4102	IWG75 VAG K03 Variant 10PSI - Black		
Exeo 1.8/2.0 TFSI	2009-2014	TS-0203-1241	Kompact VAG 2.0T V2 - Plumb Back	TS-0645-2052	IWG75 VAG K03 Variant 5PSI - Black	TS-0720-1002	Black
		TS-0203-1041	Kompact VAG 2.0T V2 - Dual Port	TS-0645-4102	IWG75 VAG K03 Variant 10PSI - Black		
Toledo 2.0 TFSI	2005-2009	TS-0203-1241	Kompact VAG 2.0T V2 - Plumb Back	TS-0645-2052	IWG75 VAG K03 Variant 5PSI - Black		
		TS-0203-1041	Kompact VAG 2.0T V2 - Dual Port				



Model	Year	BOV Part No.	BOV Description	IWG Part No.	IWG Description	BRA Part No.	BRA Description
Octavia RS 2.0 TFSI	2004-2013	TS-0203-1241	Kompact VAG 2.0T V2 - Plumb Back	TS-0645-2052	IWG75 VAG K03 Variant 5PSI - Black	TS-0720-1002	Black
		TS-0203-1041	Kompact VAG 2.0T V2 - Dual Port	TS-0645-4102	IWG75 VAG K03 Variant 10PSI - Black		
Octavia RS 2.0 TSI	2013-current	TS-0203-1263	Kompact Shortie - EVR05 Plumb Back			TS-0720-1010	Black
		TS-0203-1063	Kompact Shortie - EVR05 Dual Port				
Superb 2.0 TFSI	2008-2015	TS-0203-1241	Kompact VAG 2.0T V2 - Plumb Back	TS-0645-2052	IWG75 VAG K03 Variant 5PSI - Black	TS-0720-1002	Black
		TS-0203-1041	Kompact VAG 2.0T V2 - Dual Port	TS-0645-4102	IWG75 VAG K03 Variant 10PSI - Black		
Superb 2.0 TSI	2015-current	TS-0203-1263	Kompact Shortie - EVR05 Plumb Back			TS-0720-1010	Black
		TS-0203-1063	Kompact Shortie - EVR05 Dual Port				







Model	Year	BOV Part No.	BOV Description	IWG Part No.	IWG Description
Forester XT	1999-2000	TS-0203-1016	Kompact Dual Port		
Forester XT	2005-2007	TS-0205-1215	Plumb Back Subaru - Blue		
		TS-0205-1216	Plumb Back Subaru - Black		
		TS-0205-1315	Supersonic Subaru - Blue		
		TS-0205-1316	Supersonic Subaru - Black		
		TS-0205-1135	Vee Port PRO Subaru - Blue		
		TS-0205-1136	Vee Port PRO Subaru - Black		
		TS-0205-1015	Dual Port Subaru - Blue		
		TS-0205-1016	Dual Port Subaru - Black		
		TS-0203-1215	Kompact Plumb Back - Subaru		
		TS-0203-1015	Kompact Dual Port - Subaru		
Forester XT (EJ25)	2008-2012	TS-0205-1309	Supersonic Mazda/Subaru - Blue		
		TS-0205-1310	Supersonic Mazda/Subaru - Black		
		TS-0205-1009	Dual Port Mazda/Subaru - Blue		
		TS-0205-1010	Dual Port Mazda/Subaru - Black		
		TS-0203-1210	Kompact Plumb Back - Subaru/Nissan		
		TS-0203-1010	Kompact Dual Port - Subaru/Nissan		
Liberty & Legacy GT	2003-2008	TS-0205-1309	Supersonic Mazda/Subaru - Blue		
		TS-0205-1310	Supersonic Mazda/Subaru - Black		
		TS-0205-1009	Dual Port Mazda/Subaru - Blue		
		TS-0205-1010	Dual Port Mazda/Subaru - Black		
		TS-0203-1210	Kompact Plumb Back - Subaru/Nissan		
		TS-0203-1010	Kompact Dual Port - Subaru/Nissan		
WRX	1997-2000	TS-0203-1016	Kompact Dual Port	TS-0605-5072	IWG75 Subaru Impreza WRX TD04 97-07 7PSI - Black
WRX	2001-2005	TS-0205-1215	Plumb Back Subaru - Blue	TS-0605-5072	IWG75 Subaru Impreza WRX TD04 97-07 7PSI - Black
		TS-0205-1216	Plumb Back Subaru - Black		
		TS-0205-1315	Supersonic Subaru - Blue		
		TS-0205-1316	Supersonic Subaru - Black		
		TS-0205-1135	Vee Port PRO Subaru - Blue		
		TS-0205-1136	Vee Port PRO Subaru - Black		
		TS-0205-1015	Dual Port Subaru - Blue		
		TS-0205-1016	Dual Port Subaru - Black		
		TS-0203-1215	Kompact Plumb Back - Subaru		
		TS-0203-1015	Kompact Dual Port - Subaru		
WRX	2006-2007	TS-0205-1215	Plumb Back Subaru - Blue	TS-0605-5072	IWG75 Subaru Impreza WRX TD04 97-07 7PSI - Black
		TS-0205-1216	Plumb Back Subaru - Black		
		TS-0205-1315	Supersonic Subaru - Blue		
		TS-0205-1316	Supersonic Subaru - Black		
		TS-0205-1015	Dual Port Subaru - Blue		
		TS-0205-1016	Dual Port Subaru - Black		
		TS-0203-1215	Kompact Plumb Back - Subaru		
		TS-0203-1015	Kompact Dual Port - Subaru		
WRX	2008	TS-0205-1309	Supersonic Mazda/Subaru - Blue	TS-0605-2052	IWG75 Subaru Impreza WRX 08 5 PSI Black
		TS-0205-1310	Supersonic Mazda/Subaru - Black		
		TS-0205-1009	Dual Port Mazda/Subaru - Blue		
		TS-0205-1010	Dual Port Mazda/Subaru - Black		
		TS-0203-1210	Kompact Plumb Back - Subaru/Nissan		
		TS-0203-1010	Kompact Dual Port - Subaru/Nissan		
WRX	2009-2014	TS-0205-1309	Supersonic Mazda/Subaru - Blue	TS-0605-1072	IWG75 Subaru WRX 2009 - 2014/WRX STI 04 - Current 7PSI - Black

# MAKE/MODEL PRODUCT FITMENT GUIDE

## Subaru Fitment Guide Continued.

Model	Year	BOV Part No.	BOV Description	IWG Part No.	IWG Description
		TS-0205-1310	Supersonic Mazda/Subaru - Black		
		TS-0205-1009	Dual Port Mazda/Subaru - Blue		
		TS-0205-1010	Dual Port Mazda/Subaru - Black		
		TS-0203-1210	Kompact Plumb Back - Subaru/Nissan		
		TS-0203-1010	Kompact Dual Port - Subaru/Nissan		
WRX	2015-current	TS-0215-1018	Subaru WRX 2015+ Smart Port BOV - Black	TS-0605-3072	IWG75 Subaru WRX MY15 7PSI
WRX STI	2001-2003	TS-0205-1215	Plumb Back Subaru - Blue		
		TS-0205-1216	Plumb Back Subaru - Black		
		TS-0205-1315	Supersonic Subaru - Blue		
		TS-0205-1316	Supersonic Subaru - Black		
		TS-0205-1135	Vee Port PRO Subaru - Blue		
		TS-0205-1136	Vee Port PRO Subaru - Black		
		TS-0205-1015	Dual Port Subaru - Blue		
		TS-0205-1016	Dual Port Subaru - Black		
		TS-0203-1215	Kompact Plumb Back - Subaru		
		TS-0203-1015	Kompact Dual Port - Subaru		
WRX STI	2004-current	TS-0205-1215	Plumb Back Subaru - Blue	TS-0605-1072	IWG75 Subaru WRX 2009 - 2014/WRX STI 04 - Current 7PSI - Black
		TS-0205-1216	Plumb Back Subaru - Black		
		TS-0205-1315	Supersonic Subaru - Blue		
		TS-0205-1316	Supersonic Subaru - Black		
		TS-0205-1015	Dual Port Subaru - Blue		
		TS-0205-1016	Dual Port Subaru - Black		
		TS-0203-1215	Kompact Plumb Back - Subaru		
		TS-0203-1015	Kompact Dual Port - Subaru		
WRX STI EJ207 Twin Scroll - VF37	2003-2007	TS-0205-1215	Plumb Back Subaru - Blue	TS-0605-4073	IWG75 Subaru WRX STI GDB Spec C EJ207 7PSI - Black
		TS-0205-1216	Plumb Back Subaru - Black		
		TS-0205-1315	Supersonic Subaru - Blue		
		TS-0205-1316	Supersonic Subaru - Black		
		TS-0205-1015	Dual Port Subaru - Blue		
		TS-0205-1016	Dual Port Subaru - Black		
		TS-0203-1215	Kompact Plumb Back - Subaru		
		TS-0203-1015	Kompact Dual Port - Subaru		
WRX STI Spec C EJ207 - VF36	2003-2007	TS-0205-1215	Plumb Back Subaru - Blue	TS-0605-4073	IWG75 Subaru WRX STI GDB Spec C EJ207 7PSI - Black
		TS-0205-1216	Plumb Back Subaru - Black		
		TS-0205-1315	Supersonic Subaru - Blue		
		TS-0205-1316	Supersonic Subaru - Black		
		TS-0205-1015	Dual Port Subaru - Blue		
		TS-0205-1016	Dual Port Subaru - Black		
		TS-0203-1215	Kompact Plumb Back - Subaru		
		TS-0203-1015	Kompact Dual Port - Subaru		





Model	Year	BOV Part No.	BOV Description
440	1987-1997	TS-0203-1222	Kompact Plumb Back - 25mm
		TS-0203-1022	Kompact Dual Port - 25mm
480	1988-1995	TS-0203-1222	Kompact Plumb Back - 25mm
		TS-0203-1022	Kompact Dual Port - 25mm
740	1984-1992	TS-0203-1222	Kompact Plumb Back - 25mm
		TS-0203-1022	Kompact Dual Port - 25mm
C30 T5	2007-2013	TS-0203-1261	Kompact Shortie - Plumb Back
		TS-0203-1061	Kompact Shortie - Dual Port
C70 T5	2008-2013	TS-0203-1261	Kompact Shortie - Plumb Back
		TS-0203-1061	Kompact Shortie - Dual Port
S40 T5	2004-2012	TS-0203-1261	Kompact Shortie - Plumb Back
		TS-0203-1061	Kompact Shortie - Dual Port
S60 T5	2011-current	TS-0203-1261	Kompact Shortie - Plumb Back
		TS-0203-1061	Kompact Shortie - Dual Port
V50 T5	2004-2012	TS-0203-1261	Kompact Shortie - Plumb Back
		TS-0203-1061	Kompact Shortie - Dual Port
V70 T5	2010	TS-0203-1261	Kompact Shortie - Plumb Back
		TS-0203-1061	Kompact Shortie - Dual Port



Model	Year	BOV Part No.	BOV Description	IWG Part No.	IWG Description	BRA Part No.	BRA Description
Golf GTi MK5 2.0L	2003-2009	TS-0203-1241	Kompact VAG 2.0T V2 - Plumb Back			TS-0720-1002	Black
		TS-0203-1041	Kompact VAG 2.0T V2 - Dual Port				
Golf GTi MK6 2.0L	2009-2013	TS-0203-1241	Kompact VAG 2.0T V2 - Plumb Back	TS-0645-2052	IWG75 VAG K03 Variant 5PSI - Black	TS-0720-1002	Black
		TS-0203-1041	Kompact VAG 2.0T V2 - Dual Port	TS-0645-4102	IWG75 VAG K03 Variant 10PSI - Black		
Golf R MK6 2.0 TFSI	2009-2013	TS-0203-1241	Kompact VAG 2.0T V2 - Plumb Back	TS-0645-1052	IWG75 VAG K04 Variant 5PSI - Black	TS-0720-1002	Black
		TS-0203-1041	Kompact VAG 2.0T V2 - Dual Port	TS-0645-3102	IWG75 VAG K04 Variant 10PSI - Black		
		TS-0215-1041	Smart Port 2.0L VAG Golf R/S3 BOV - Black				
Golf GTi MK7 2.0 TSI	2013-current	TS-0203-1263	Kompact Shortie - EVR05 Plumb Back			TS-0720-1010	Black
		TS-0203-1063	Kompact Shortie - EVR05 Dual Port				
Golf R MK7 2.0 TSI	2013-current	TS-0203-1263	Kompact Shortie - EVR05 Plumb Back			TS-0720-1010	Black
		TS-0203-1063	Kompact Shortie - EVR05 Dual Port				
Scirocco R 2.0 TFSI	2008-2014	TS-0203-1241	Kompact VAG 2.0T V2 - Plumb Back			TS-0720-1002	Black
		TS-0203-1041	Kompact VAG 2.0T V2 - Dual Port				
		TS-0215-1041	Smart Port 2.0L VAG Golf R/S3 BOV - Black				
Scirocco R 2.0 TSI	2015-current	TS-0203-1263	Kompact Shortie - EVR05 Plumb Back			TS-0720-1010	Black
		TS-0203-1063	Kompact Shortie - EVR05 Dual Port				
Beetle 1.8T 20v	1998-2011	TS-0203-1222	Kompact Plumb Back - 25mm				
		TS-0203-1022	Kompact Dual Port - 25mm				
Polo GTi 1.8T 20v	2005-2009	TS-0203-1222	Kompact Plumb Back - 25mm				
		TS-0203-1022	Kompact Dual Port - 25mm				
Passat 1.8T 20v	1999-2005	TS-0203-1222	Kompact Plumb Back - 25mm				
		TS-0203-1022	Kompact Dual Port - 25mm				
Golf Mk4 1.8T 20v	1998-2006	TS-0203-1222	Kompact Plumb Back - 25mm				
		TS-0203-1022	Kompact Dual Port - 25mm				

# MAKE/MODEL PRODUCT FITMENT GUIDE

## VW Fitment Guide Continued.

Model	Year	BOV Part No.	BOV Description	IWG Part No.	IWG Description	BRA Part No.	BRA Description
Jetta 1.8T 20v	1999-2006	TS-0203-1222	Kompact Plumb Back - 25mm				
		TS-0203-1022	Kompact Dual Port - 25mm				
Jetta 2.0L TSI	2006-2011	TS-0203-1241	Kompact VAG 2.0T V2 - Plumb Back	TS-0645-2052	IWG75 VAG K03 Variant 5PSI - Black	TS-0720-1002	Black
		TS-0203-1041	Kompact VAG 2.0T V2 - Dual Port	TS-0645-4102	IWG75 VAG K03 Variant 10PSI - Black		
Jetta 2.0L TSI	2011-current	TS-0203-1263	Kompact Shortie - EVR05 Plumb Back			TS-0720-1010	Black
		TS-0203-1063	Kompact Shortie - EVR05 Dual Port				
Tiguan 2.0L TFSI	2007-current	TS-0203-1241	Kompact VAG 2.0T V2 - Plumb Back	TS-0645-2052	IWG75 VAG K03 Variant 5PSI - Black	TS-0720-1002	Black
		TS-0203-1041	Kompact VAG 2.0T V2 - Dual Port	TS-0645-4102	IWG75 VAG K03 Variant 10PSI - Black		
Passat 2.0L TFSI	2006-2015	TS-0203-1241	Kompact VAG 2.0T V2 - Plumb Back	TS-0645-2052	IWG75 VAG K03 Variant 5PSI - Black	TS-0720-1002	Black
		TS-0203-1041	Kompact VAG 2.0T V2 - Dual Port	TS-0645-4102	IWG75 VAG K03 Variant 10PSI - Black		
Passat 1.8L TFSI	2009-2015	TS-0203-1241	Kompact VAG 2.0T V2 - Plumb Back	TS-0645-2052	IWG75 VAG K03 Variant 5PSI - Black	TS-0720-1002	Black
		TS-0203-1041	Kompact VAG 2.0T V2 - Dual Port	TS-0645-4102	IWG75 VAG K03 Variant 10PSI - Black		
Passat 2.0L\1.8L TSI	2015-current	TS-0203-1263	Kompact Shortie - EVR05 Plumb Back			TS-0720-1010	Black
		TS-0203-1063	Kompact Shortie - EVR05 Dual Port				
CC 2.0L TFSI	2012-current	TS-0203-1241	Kompact VAG 2.0T V2 - Plumb Back	TS-0645-2052	IWG75 VAG K03 Variant 5PSI - Black	TS-0720-1002	Black
		TS-0203-1041	Kompact VAG 2.0T V2 - Dual Port	TS-0645-4102	IWG75 VAG K03 Variant 10PSI - Black		
Eos 2.0L TFSI	2006-current	TS-0203-1241	Kompact VAG 2.0T V2 - Plumb Back	TS-0645-2052	IWG75 VAG K03 Variant 5PSI - Black	TS-0720-1002	Black
		TS-0203-1041	Kompact VAG 2.0T V2 - Dual Port	TS-0645-4102	IWG75 VAG K03 Variant 10PSI - Black		
Sportswagen 2.0L TFSI	2009-2014	TS-0203-1241	Kompact VAG 2.0T V2 - Plumb Back			TS-0720-1002	Black
		TS-0203-1041	Kompact VAG 2.0T V2 - Dual Port				
Beetle 2.0L TSI	2012-current	TS-0203-1263	Kompact Shortie - EVR05 Plumb Back	TS-0645-2052	IWG75 VAG K03 Variant 5PSI - Black	TS-0720-1010	Black
		TS-0203-1063	Kompact Shortie - EVR05 Dual Port	TS-0645-4102	IWG75 VAG K03 Variant 10PSI - Black		
Beetle Cabrio 2.0L TSI	2013-current	TS-0203-1263	Kompact Shortie - EVR05 Plumb Back	TS-0645-2052	IWG75 VAG K03 Variant 5PSI - Black	TS-0720-1010	Black
		TS-0203-1063	Kompact Shortie - EVR05 Dual Port	TS-0645-4102	IWG75 VAG K03 Variant 10PSI - Black		
Golf MK5 ED30	2006-2009	TS-0203-1263	Kompact Shortie - EVR05 Plumb Back	TS-0645-1052	IWG75 VAG K04 Variant 5PSI - Black		
		TS-0203-1063	Kompact Shortie - EVR05 Dual Port	TS-0645-4102	IWG75 VAG K04 Variant 10PSI - Black		
Golf Cabrio 2.0L TSI	2012-current	TS-0203-1263	Kompact Shortie - EVR05 Plumb Back			TS-0720-1010	Black
		TS-0203-1063	Kompact Shortie - EVR05 Dual Port				
Scirocco 2.0 TFSI	2009-2014	TS-0203-1241	Kompact VAG 2.0T V2 - Plumb Back	TS-0645-2052	IWG75 VAG K03 Variant 5PSI - Black		
		TS-0203-1041	Kompact VAG 2.0T V2 - Dual Port	TS-0645-4102	IWG75 VAG K03 Variant 10PSI - Black		
Scirocco 2.0 TFSI	2015-on	TS-0203-1263	Kompact Shortie - EVR05 Plumb Back				
		TS-0203-1063	Kompact Shortie - EVR05 Dual Port				
Sharan 1.8L\2.0L TFSI	2011-2015	TS-0203-1241	Kompact VAG 2.0T V2 - Plumb Back	TS-0645-2052	IWG75 VAG K03 Variant 5PSI - Black	TS-0720-1002	Black
		TS-0203-1041	Kompact VAG 2.0T V2 - Dual Port	TS-0645-4102	IWG75 VAG K03 Variant 10PSI - Black		
Sharan 2.0L TSI	2015-current	TS-0203-1263	Kompact Shortie - EVR05 Plumb Back			TS-0720-1010	Black
		TS-0203-1063	Kompact Shortie - EVR05 Dual Port				
Touran	2016-current	TS-0203-1263	Kompact Shortie - EVR05 Plumb Back			TS-0720-1010	Black
		TS-0203-1063	Kompact Shortie - EVR05 Dual Port				

