

TURBO ACTION



CHEETAH SCS SHIFTER

Part #70003B

Fits: Ford C4 (1964-Up) & Ford C6 (1966-Up)

(Note: Will not fit any four-speed automatic transmissions)

Parts Breakdown

- 1 - Ford Control
- 1 - 70080B Gear Position Indicator Decal (PRN123)
- 1 - 70081B Gear Position Indicator Decal (PRN321)
- 1 - 70102 Special Five Foot Cable (On Shifter)
- 1 - 70200A Control Switch 10AMP (On Shifter)
- 1 - 70211 Park/Neutral Start Switch Kit (Ford & GM Only)
 - Includes:
 - 1 - 70210A Switch
 - 1 - 70049 Switch Mounting Bracket
 - 2 - 70154 Nylon Rollers (On Shifter)
 - 2 - 70155 Clevis Pins (On Shifter)
 - 2 - 70136A Cotter Pins (On Shifter)
 - 1 - 70139 Switch Nut
- 1 - 70222 Installation Kit
 - Includes:
 - 1 - Set of Instructions
 - 1 - 70034 C4 Shift Lever
 - 1 - 70035 C6 Shift Lever
 - 1 - 70036-1 Shaft for C4 & C6 Shift Lever
 - 1 - 70054 Ford Pan Cable Bracket
 - 1 - 70130S Pivot
 - 1 - 70136B Hairspring Cotter
 - 1 - 70140 Cable Clamp (U-Shaped)
 - 1 - 70141A Shim Block
 - 2 - 70147 Pan Bolts 5/16-18 X 3/4" (7/16" Head)
 - 2 - 70151 Cable Clamp Hex Nuts (1/4-28 Nylon Lock)
 - 1 - 70160 Nut for Shaft #70036-1
 - 1 - 70162 Internal Tooth Lock Washer for Shaft #70036-1
 - 1 - 00255-1 Set Screw
 - 2 - 70134 3/8" Flat Washers
- 2 - 50101 Contingency Decals

The Turbo Action *Cheetah Competition SCS Shifter* is the finest competition shifter built today! If installed properly, it will last for many years with flawless performance.

This shifter will work with stock pattern and/or reverse pattern valve bodies.

FIRST, READ INSTRUCTIONS CAREFULLY, THEN PROCEED WITH EACH STEP INDIVIDUALLY.

Use Lifter Only To Go into Reverse. The unique reverse lockout system requires only that you lift the reverse lockout mechanism with your two fingers while placing into reverse with the same hand. **Note:** **Do NOT** lift mechanism for any other shift!

CAUTION: In a race it is imperative that the forward gears be precise in relation to the shifter.

CAUTION! CAUTION! ***Be absolutely sure that vehicle is in park or neutral position before attempting to start motor, and be sure that park/neutral safety switch is adjusted properly.***

SPECIAL NOTE: Sanctioned dragstrips require functional Neutral Safety Switch mandatory.

STEP # 1: The Shifter is preassembled and only requires locating a suitable spot to mount it and hooking up the necessary bracket to hang cable to side of the transmission.

STEP # 2: If mounting shifter on thin floor pan, such as a Super Gas or Econo-Altered, would suggest putting a thin steel strapping behind the floor pan to offer a support where the shifter mounting bolts go through. Be sure to locate shifter in a position which will be comfortable for the driver to shift. After drilling holes in floor, start two rear bolts and make finger tight. Two front bolts leave out at this time; as you will be installing your Park/Neutral Start Switch Mounting Bracket later.

SPECIAL NOTE: The Ford Shifter #70003B has the cable exiting out the rear of the control towards the rear end. It then makes a 180 degree turn back towards engine. The cable should in most cases go under the cross member and then mount to the transmission.

STEP # 3: The cable included with this shifter is very unique. You can make many tight radius turns and it will still work smoothly. It also is very sturdy even though it is highly flexible.

STEP # 4: When routing the cable, be sure to keep away from rotating parts (driveshaft, u-joints, etc.) and hot parts (headers, mufflers, etc.). **NOTE:** On installation if you will come through floor pan as close to the driver's side of the hump as possible, the cable will then lie snug against the side of hump and will be 4-5 inches from the driveshaft. If necessary, use some plastic ties to keep cable from moving around.

STEP # 5: The installation of shaft #70036-1 will make it necessary to remove your valve body. If you have a C4 valve body, proceed with STEP #6 thru #14. If you have a C6 valve body, proceed with STEPS #15 thru #23.

Use Only Steps #6 thru #14 if C4 Valve Body.
(Advance ahead to Step #15 if C6 Valve Body.)

STEP # 6: Transmission should be cool before removing valve body. If vehicle is on the ground, secure so it will not roll. Drain transmission oil by carefully removing pan bolts. Recommend leaving a couple of bolts attached until some of the oil has drained out.

- STEP # 7: Before removing valve body TAKE NOTE how the small passing gear linkage on the outside of the case, driver's side, moves back and forth. Note how it springs back smoothly, no bind.
- STEP # 8: Take 7/16" socket and remove the eight or nine bolts which hold the valve body in place. Carefully lower valve body.
- STEP #9: The valve body is a very intricate part of the transmission, therefore requires a clean place to be laid down. If you take your time, you will have no problem installing Shaft #70036-1.
- STEP #10: Remove old shift lever and smaller passing gear shaft. If the transmission is to be used for competition use only, you will no longer need the passing gear shaft or linkage. Install Set Screw #00255-1 into end of Shaft #70036-1. You will tighten Set Screw in Step #27. If unit is for street or you wish to retain the passing gear linkage, then leave out Set Screw. Install #70036-1 Shaft with appropriate linkage. NOTE: If using set screw, use teflon tape to seal.
- STEP #11: Before installing valve body, NOTE the levers in the transmission which engage the Manual Control Valve and the Passing Gear Valve. They must line up with valve body properly. Passing gear valve not used in competition units.
- STEP #12: Lift the valve body into the transmission, carefully align the Manual Control Valve with the shift linkage (Fig. #1). At the same time, wiggle the Passing Gear Linkage on the outside of the transmission case until it feels like mentioned in Step #7. Passing gear linkage not used on competition units.
- STEP #13: Start all bolts (Note long one goes through filter). Tighten all bolts down being sure that the shift linkage and passing gear linkage are working properly. Bolts should be 8-10 ft/lbs. Passing gear linkage not used on competition units.
- STEP #14: Clean pan and install a new pan gasket. Reinstall pan on transmission and tighten all bolts.

USE STEPS #15 thru #23 if C6 VALVE BODY.

- STEP #15: Transmission should be cool before removing valve body. If vehicle is on the ground, secure so it will not roll. Drain transmission oil by carefully removing pan bolts. Recommend leaving a couple of bolts partially attached until some of the oil has drained out.
- STEP #16: Before removing valve body, take note how the small passing gear linkage on the outside of the case, driver's side, moves back and forth. Note how it springs back smoothly, no bind.
- STEP #17: Take 3/8" socket and remove the eight bolts which hold the valve body in place. Carefully lower valve body.
- STEP #18: The valve body is a very intricate part of the transmission and, therefore requires a clean place to be laid down. Also, you must take your time and you will have no problems installing the Shaft #70036-1.

STEP #19: Same as Step #10.

STEP #20: Before installing valve body, note the levers in the transmission which engage the Manual Control Valve and the Downshift Valve. They must line up with the valve body properly. Downshift valve not used in competition units.

STEP #21: Lift valve body into transmission, carefully aligning the Manual Control Valve (Fig. #1) with the Shift Linkage. At the same time, wiggle the passing gear linkage on the outside of transmission case until it feels like mentioned in STEP #16. Passing gear not used in competition units.

STEP #22: Start all bolts (Note two long bolts go through filter). Tighten all bolts down being sure that the shift lever and passing gear linkage are working properly. Bolts should be tightened to 8-10ft/lbs. Passing gear linkage not used in competition units.

STEP #23: Clean pan and install a new pan gasket. Replace pan on transmission and tighten all bolts securely.

THE FOLLOWING STEPS ARE FOR ALL APPLICATIONS:

STEP #24: Install U-Shaped Cable Clamp around groove in the end of the cable, then slide through Shim Block and then through Pan Cable Bracket. Install lock nuts only finger tight at this time. (Fig. #2 & #3).

STEP #25: Install Pan Cable Bracket on pan with the two special Pan Bolts #70147 and tighten.

STEP #26: Now tighten U-Clamp Nuts. **DO NOT OVER TIGHTEN!**

STEP #27: Install C4 or C6 lever, depending on type of transmission. Note: Large nut on internal tooth lock washer should only be tightened to 15-20 ft/lbs. If street unit, install O-ring from old shift lever shaft. Most transmissions will then require the two 3/8" flat washers #70134 installed on passing gear linkage shaft. Then put the passing gearlinkage and nut intoplace and be sure to tighten. Be sure linkage turns free. Early C4's no washers required. If competition unit, hold Shift Lever and tighten Set Screw. Don't forget to use teflon tape to seal set screw.

STEP #28: Install Pivot on cable. Pull Shift Lever on transmission towards rear of car.

STEP #29: When you adjust your shifter for competition, be sure to adjust as follows: Sometimes you will have to loosen up U-Shaped Cable Clamp to get proper angle on Shift Lever to make adjustment. However, be sure you tighten before final adjustment check.

- a. Place shifter in low if stock pattern (PRN321) or high if reverse pattern (PRN123).
- b. Place transmission Shift Lever in same position which will be pulled back all the way towards rear of car.
- c. Adjust Pivot to fit into hole in Shift Lever.
- d. Before installing Hairspring Cotter, have someone sit in car and move shifter lever through each gear while you check to see if Shift Lever on transmission is moving the full distance.

CAUTION, VERY IMPORTANT: When installing the CHEETAH SCS Shifter, you must use the Turbo Action Shift Lever and Mounting Bracket supplied or otherwise improper alignment of shifter will occur causing possible transmission failure or miss shifts.

CAUTION In a race car it is imperative that the forward gears be precise in relation to the shifter.

STEP #30: Note Fig. #2 & #3 for position of Hairspring Cotter. For C4 it is outside, away from transmission. For C6 it is inside, towards transmission.

STEP #31: Wire Park/Neutral Switch into your wiring per (Fig. #6).

STEP #32: Install #70210A Switch and #70139 Switch Nut to the #70049 Switch Mounting Bracket (Fig. #4).

STEP #33: Slide the Switch Mounting Bracket underneath the shifter mounting brackets. Reinstall the bolts into floor, but do not tighten all the way at this time (Fig. #5).

STEP #34: Note that the switch can slip up and down. In addition, the Switch Mounting Bracket can be slid forward and back. Before adjusting switch, be sure STEP #29 has been completed.

STEP #35: Adjust switch and bracket until both Park & Neutral will allow the vehicle's engine to start. Also, double check to be sure the vehicle will not start in reverse or any forward gear positions.

STEP #36: Be sure all bolts are secured properly, including the final tightening up of the bolts mentioned in STEP #33.

STEP #37: Be sure to add necessary oil before starting. Use popular brand Type "F" fluid! C4 approximately 3 quarts. C6 approximately 5 quarts.

STEP #38: Start motor and add transmission fluid until dip stick reads approximately 1 pint low, or to the "add" mark.

STEP #39: Take vehicle out and drive normally around the block. Now recheck transmission oil level. Add oil if necessary, but DO NOT OVERFILL!

CAUTION: *In a race car it is imperative that the forward gears be precise in relation to the shifter.*

CAUTION! CAUTION! *Be absolutely sure that vehicle is in Park or Neutral Position before attempting to start motor.*

FIGURE #1
(See STEPS #12 and #21)

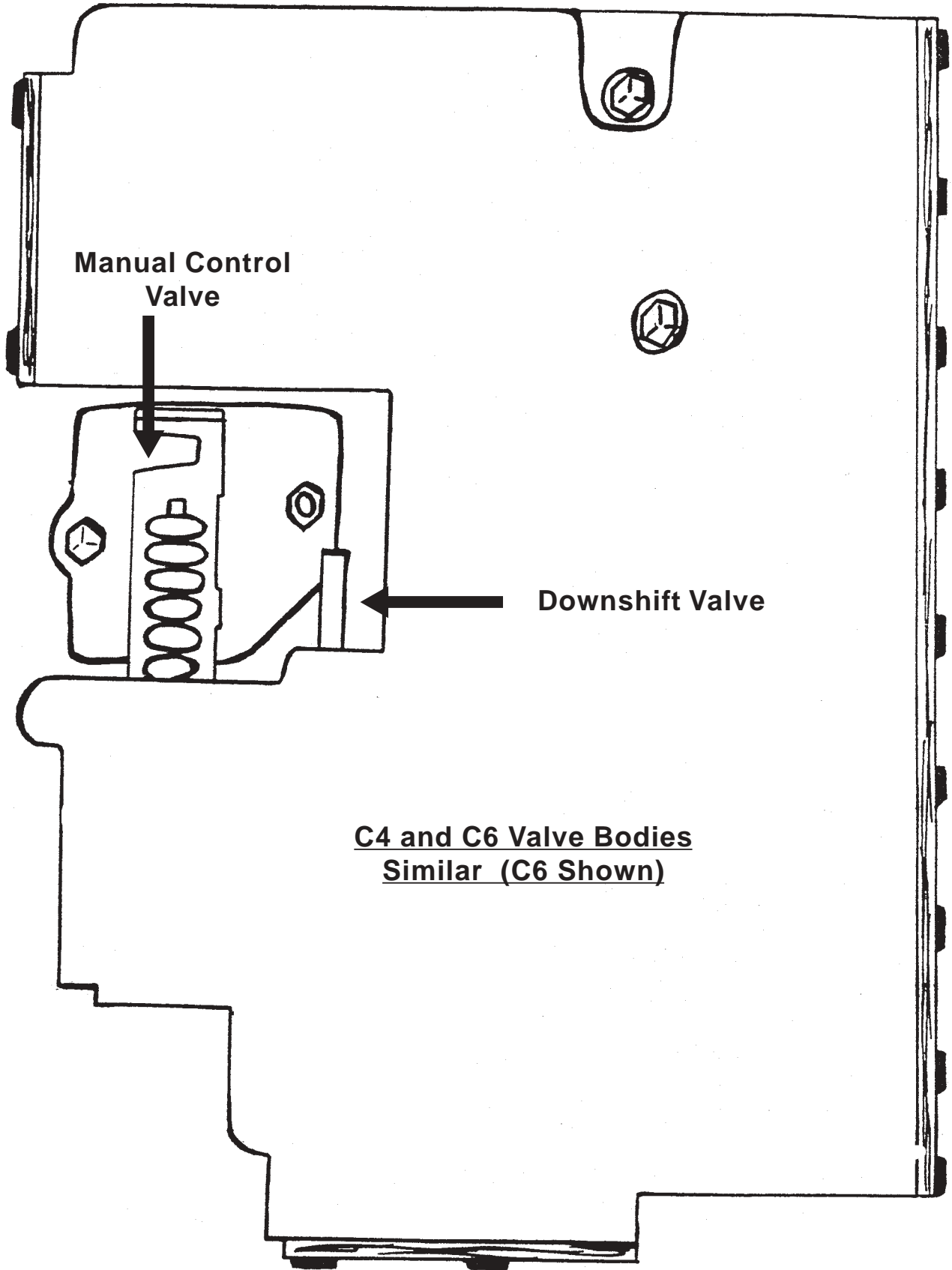

C4 and C6 Valve Bodies
Similar (C6 Shown)

FIGURE #2

C4 Cable/Bracket Installation

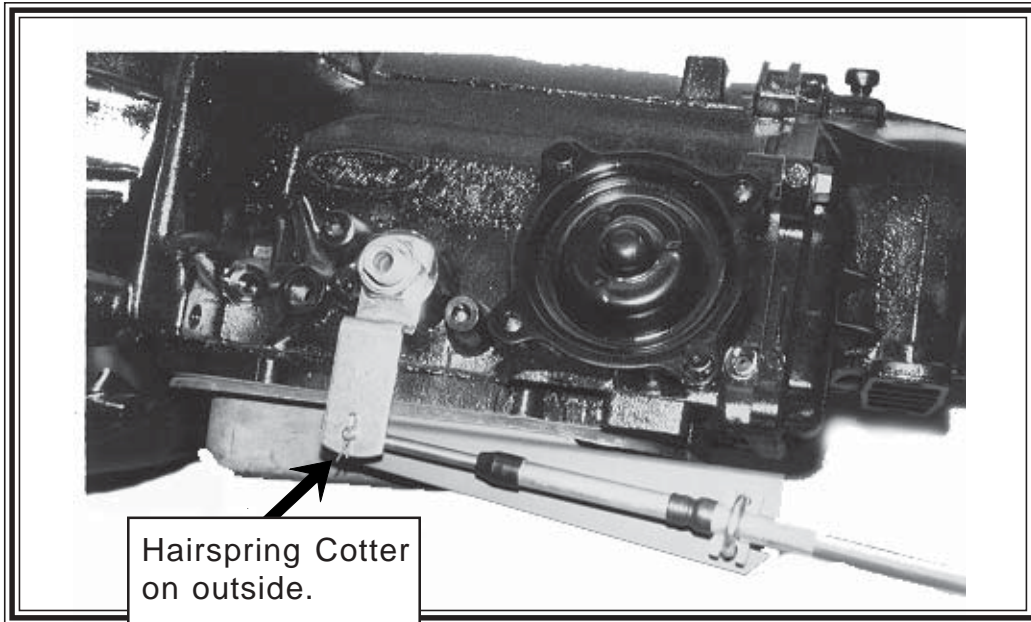
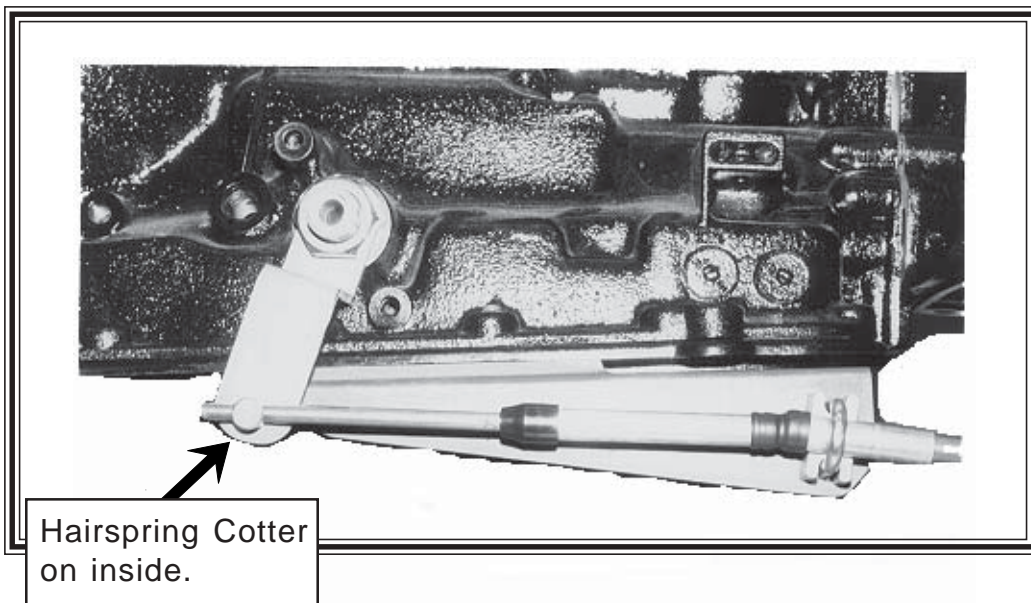

FIGURE #3

C6 Cable/Bracket Installation



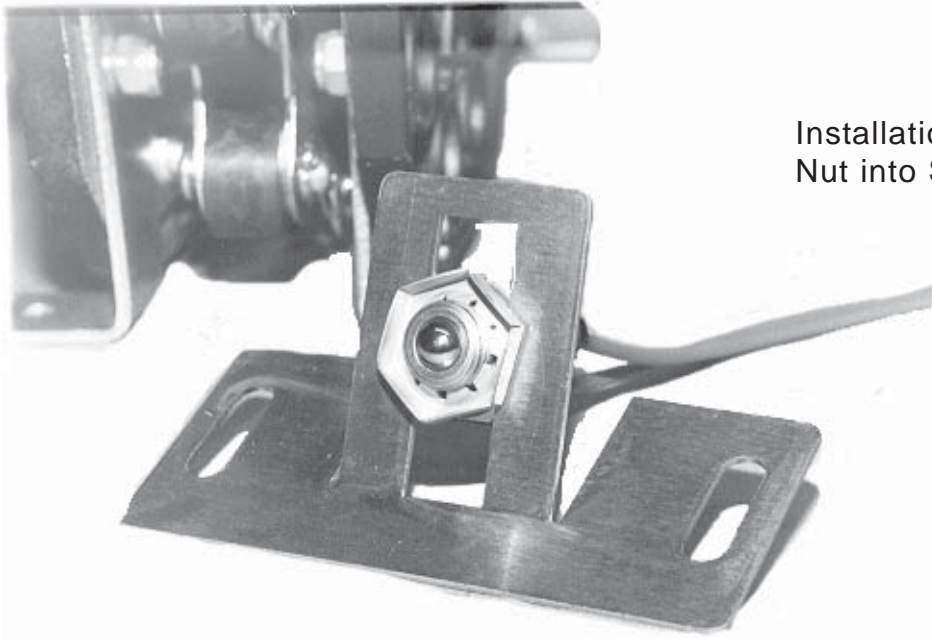

Fig. #4
Installation of Switch & Switch Nut into Switch Mounting Bracket

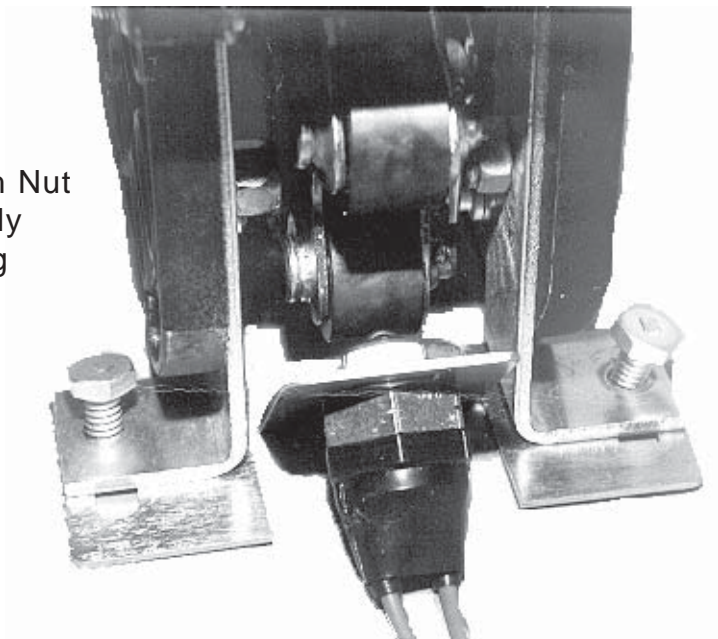

Fig. #5
Installation of Switch, Switch Nut & Mounting Bracket Assembly Underneath Shifter Mounting Brackets

Fig. #6
Wire Switch

Suggested Wiring Diagram

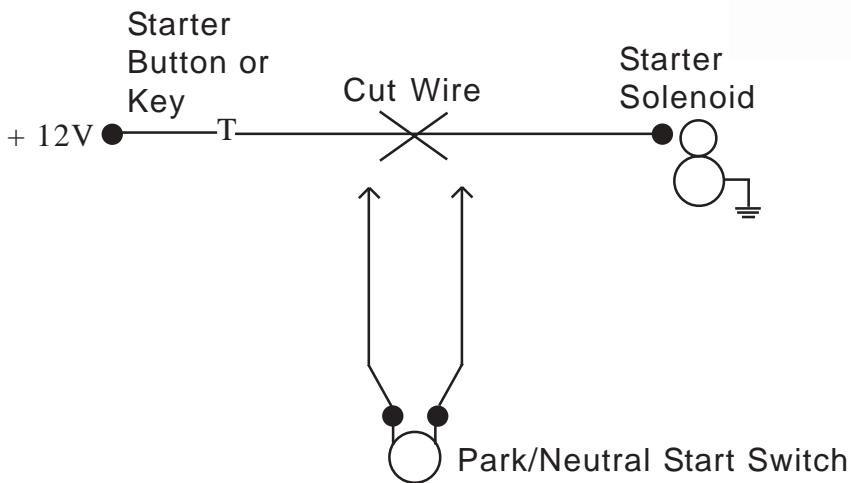

Fig. #7
ControlSwitch Kit - #70205
and
T-Handle Kit - #70061

