

**17156**

## Upper Valve Body Assembly

The following pages show the two types assemblies of the 17156 CHEETAH VB using different cores.

**Note:** The long valve (1-2 Control Valve) is blocked with a 1/4" ball. This valve is not in all valve bodies.

The 7/32" ball goes on top of the shorter long valve (1-2 Shift Valve) as shown in all 17156 valve bodies.

The kickdown assembly is different than stock so be sure you put all valves back as shown on these photos.

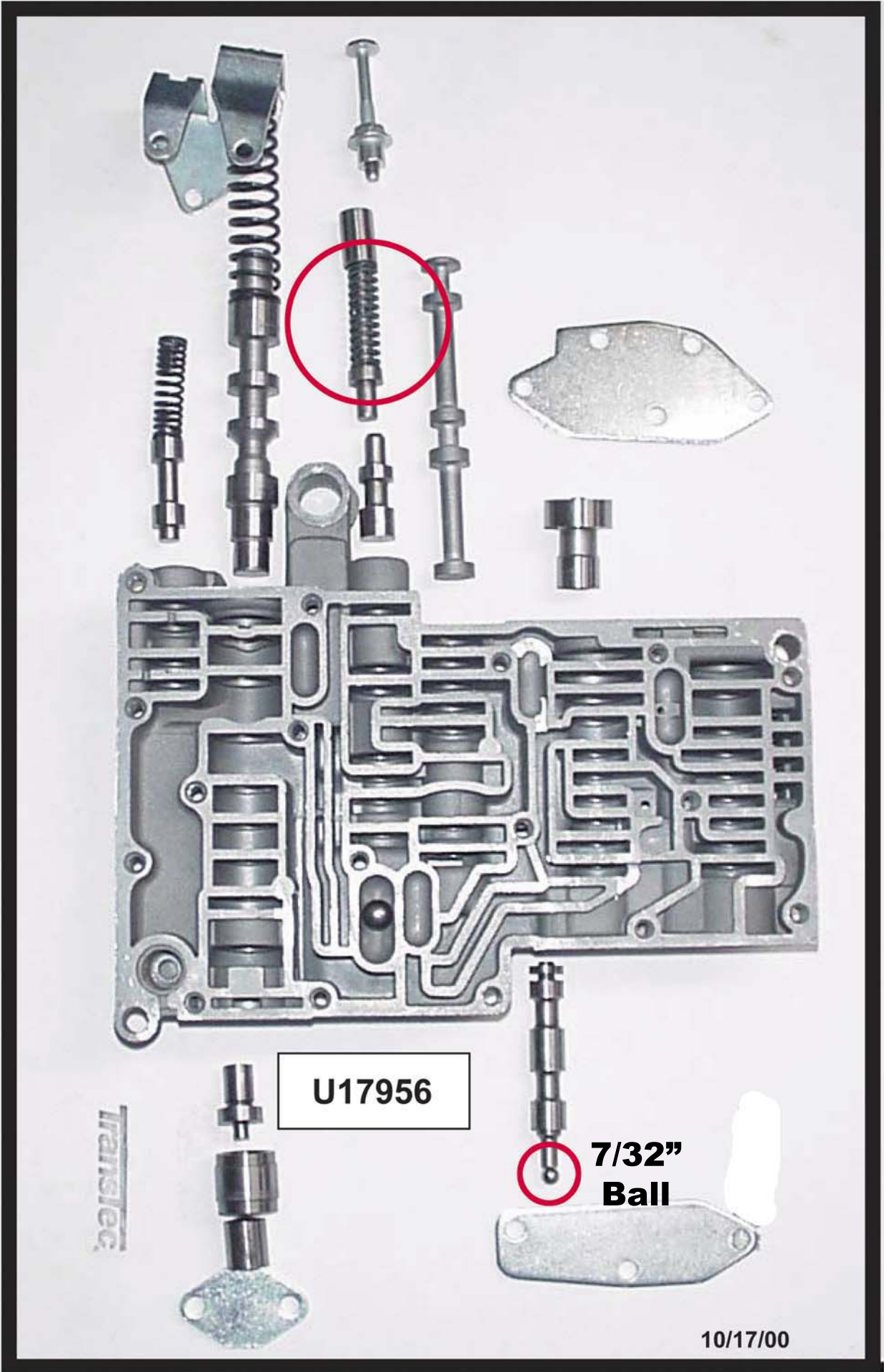

U17956

7/32"  
Ball

Trans-Jec

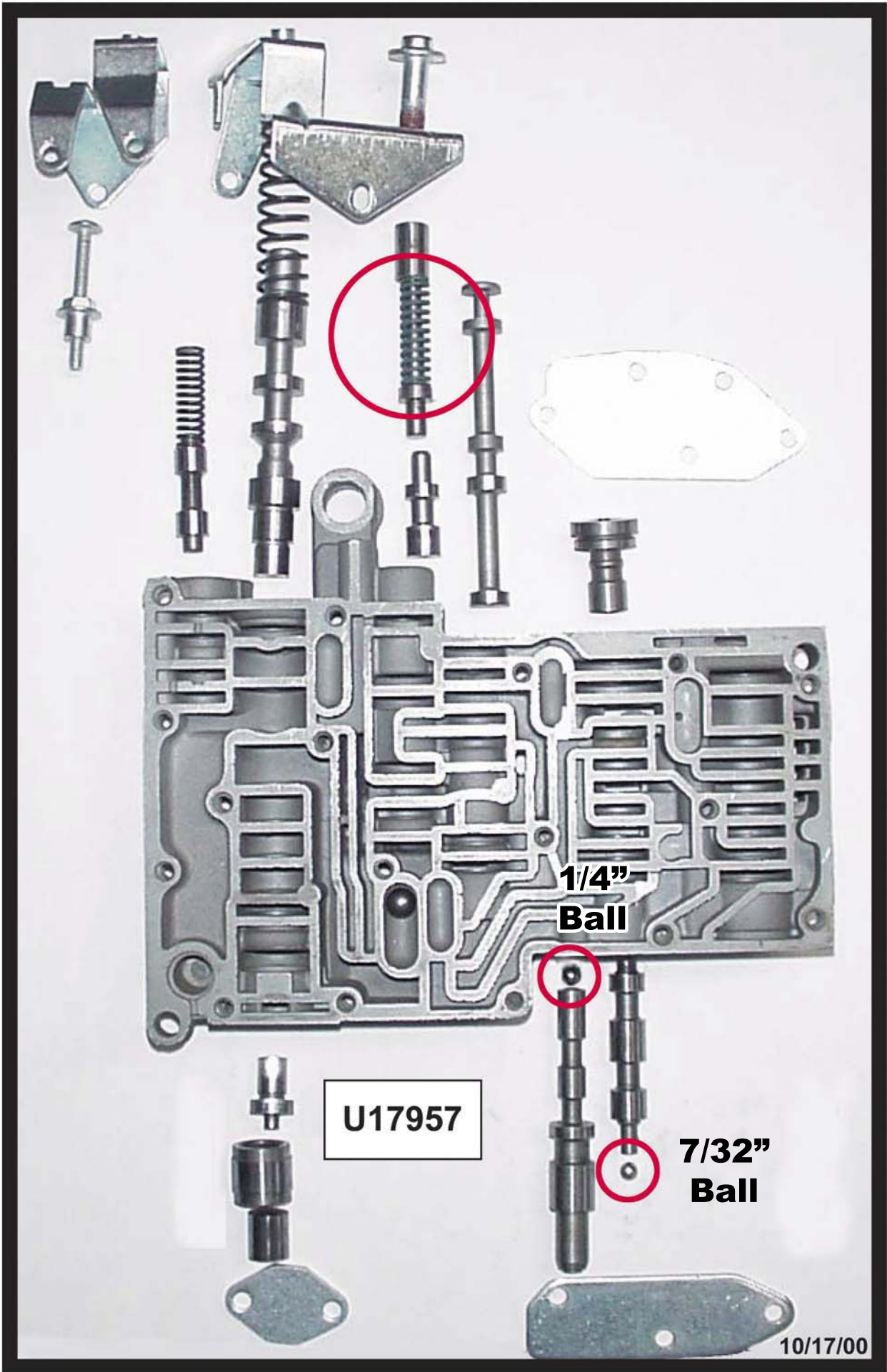

**1/4"  
Ball**

**U17957**

**7/32"  
Ball**