



INSTALLATION INSTRUCTIONS

2019+ Ram In-floor Storage Security Lid #357

QC CHECK

- ____ SHIP PACK CONTENTS
- ____ VISUAL INSPECTION
- ____ RUBBER BUMPERS
- ____ LOCK FUNCTION TEST
- ____ SHIPPING/KEY PACK

PARTS CHECKLIST



Security Lid #357

SHIPPING PACKAGE CONTENTS (PLACED IN KEY BAG)

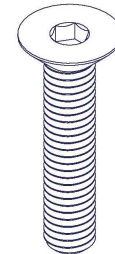

#6.1 (6) 6mm x 30mm
Flathead Screw

Tools needed for standard installation:

- Flat Head Screwdriver
- Torx T-40 Wrench
- Torx T-30 Wrench
- 10mm Wrench
- 4mm Hex Wrench
- Cutting Tool(Optional)

PLEASE READ ALL INSTRUCTIONS THOROUGHLY BEFORE STARTING INSTALLATION.

1. Pull back the carpet panel that covers the footwell area of the rear seat to reveal the OEM plastic storage lid.
2. Open the OEM storage lid and remove the OEM plastic liner and set it aside for future use.
3. Release the plastic covers over the (2) cargo loops using a flat blade screwdriver. A slight upward “pry” at the rear of the cover will release the internal clip holding it down.
4. Remove the (2) OEM mount bolts for the cargo loops and remove the cargo loops. Separate the mount bolts from the cargo loops and reinstall the bolts into the mounting holes to prevent water from entering the vehicle.
5. Remove the (4) mounting bolts from the OEM lid and set the lid aside.
6. Remove the (2) OEM hex-head bolts that secure the plastic housing/cavity in place and replace them with (2) #6.1 Flathead Screws.
7. Place the #357 Security Lid in place on the carpeted floor.
8. Insert (4) #6.1 Flathead Screws from the shipping package, through the holes in the #357 Mount Plate and into the factory mounting holes. (SEE FIGURE 1)

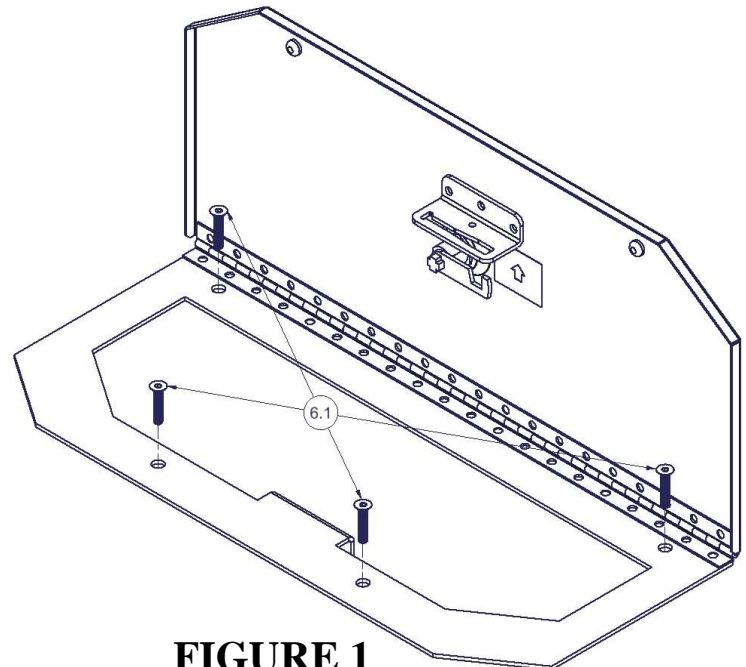

FIGURE 1

9. Tighten the (4) #6.1 Flathead Screws to approximately 5 ft-lbs ensuring that the #357 Mount Plate rests evenly on top of the OEM plastic housing/cavity and carpet.

NOTE: To maximize secure storage space the #357 Security Lid may be used without the OEM plastic liner installed. Continued use of the plastic liner is possible with the following modifications.

Optional Steps: Modifying OEM Plastic Liner

1. In order to clear the lock bracket, a notch must be cut in the upper forward edge of the plastic liner. This notch is located between the 7cm and 16cm marks (formed in the lip of the liner) and extends down 1½" from the upper lip of the liner. (SEE FIGURE 3)
2. The "ears" on either side of the liner must be removed down to a level where they will not interfere with the #357 Security Lid as it is closed and locked. (SEE FIGURES 2 AND 3)

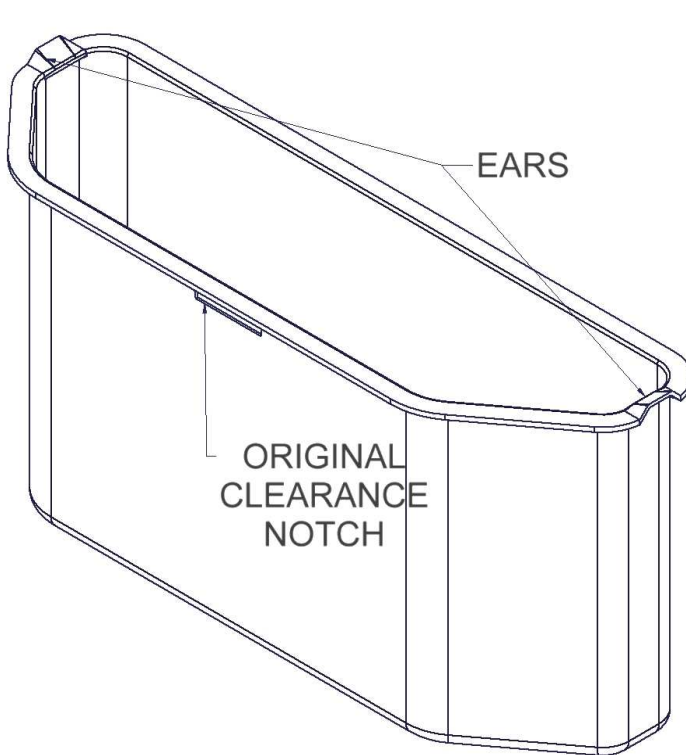

FIGURE 2
OEM CONDITION

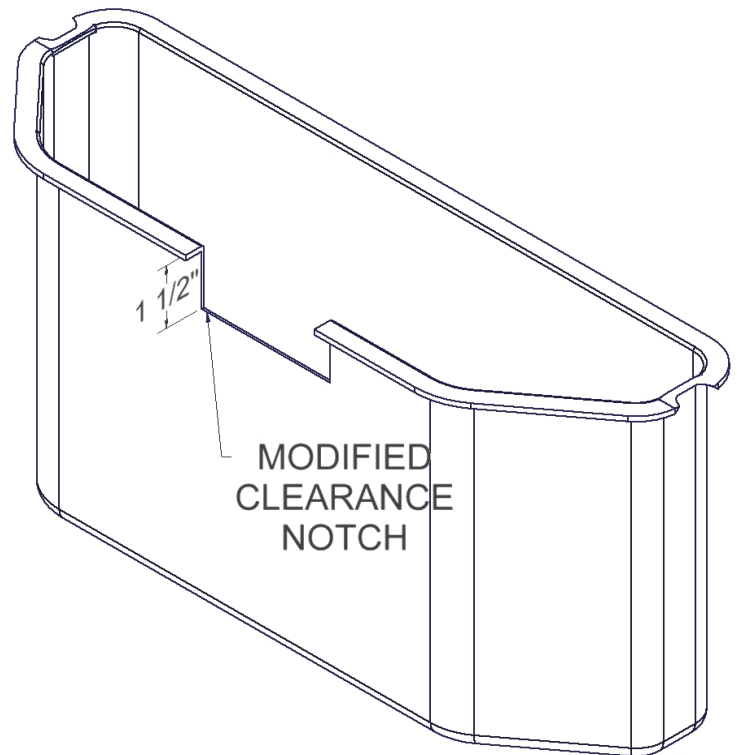

FIGURE 3
AFTER MODIFICATION