

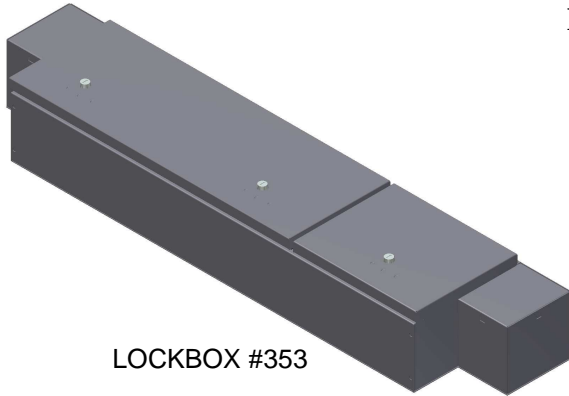

INSTALLATION INSTRUCTIONS

2019+ RAM Crewcab Under Rear-Seat Lockbox #353

PARTS CHECKLIST



LOCKBOX #353

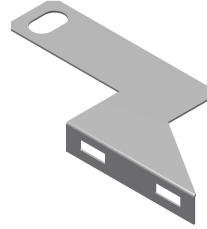

#8.5 MOUNTING BRACKET
(PASSENGER SIDE)



#8.4 MOUNTING BRACKET
(DRIVER SIDE)



#8.1 (4) 5/16" WING KNOB NUTS

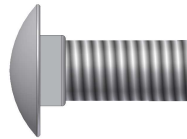

#8.2 (4) 5/16" x 3/4" CARRIAGE BOLTS

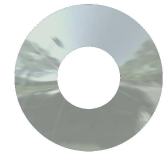

#8.3 (4) 3/8" WASHERS

Tools needed for standard installation

- 10mm Wrench

Tools Used to Remove Optional Factory Storage Unit

- Flat Blade Screwdriver
- T-20 Torx Wrench

PLEASE READ ALL INSTRUCTIONS THOROUGHLY BEFORE STARTING INSTALLATION.

1. Flip both rear seat bottoms up so they are secured in the upright position.

THESE STEPS APPLY ONLY TO VEHICLES WITH OPTIONAL UNDER REAR SEAT STORAGE UNIT

2. Rotate/release the retainer in the middle of the Storage Unit and rotate the Unit to the open/forward position.
3. Remove the bolts from the end plates that secure the Storage Unit to the seat mount pedestals on either side of the Unit. Three bolts hold each side.
4. Remove the Storage Unit by lightly prying one of the end plates toward the center of the vehicle and pivoting that end of the Unit toward the front of the vehicle.
5. Once removed from the vehicle, the end plates may be removed from the Storage Unit by removing the pivot bolts. The end plates may then be reinstalled to the vehicle using the original hardware (Removed in Step #3).
6. Remove the plastic cover that surrounds the retainer. There are two "pressure clips" that hold it in place, one above the retainer (slightly off-center to the Passenger Side), and one below (slightly off-center to the Driver Side).
7. Take out the two bolts holding the retainer bracket to the body tub and remove the retainer bracket.
8. Using a 10mm Wrench (closed end) remove both forward outermost seat mount bolts (one on the driver side, one on the passenger side).
9. Alternately slip the #8.4 and #8.5 Mounting Brackets between the seat mount brackets and the seat mount pedestals of the vehicle so that the mounting holes may be clearly seen through the obround holes in the Mounting Brackets. The Mounting Brackets should extend toward the middle of the vehicle. **See Figure 1 (Reverse Side).**

10. Replace, **but do not tighten** the seat mount bolts securing the Mounting Brackets to the vehicle. **NOTE:** A security bolt kit (Part #887-001)
11. Place the #353 Lockbox in the floorboard area of the vehicle and slide it into place against the mounting brackets.

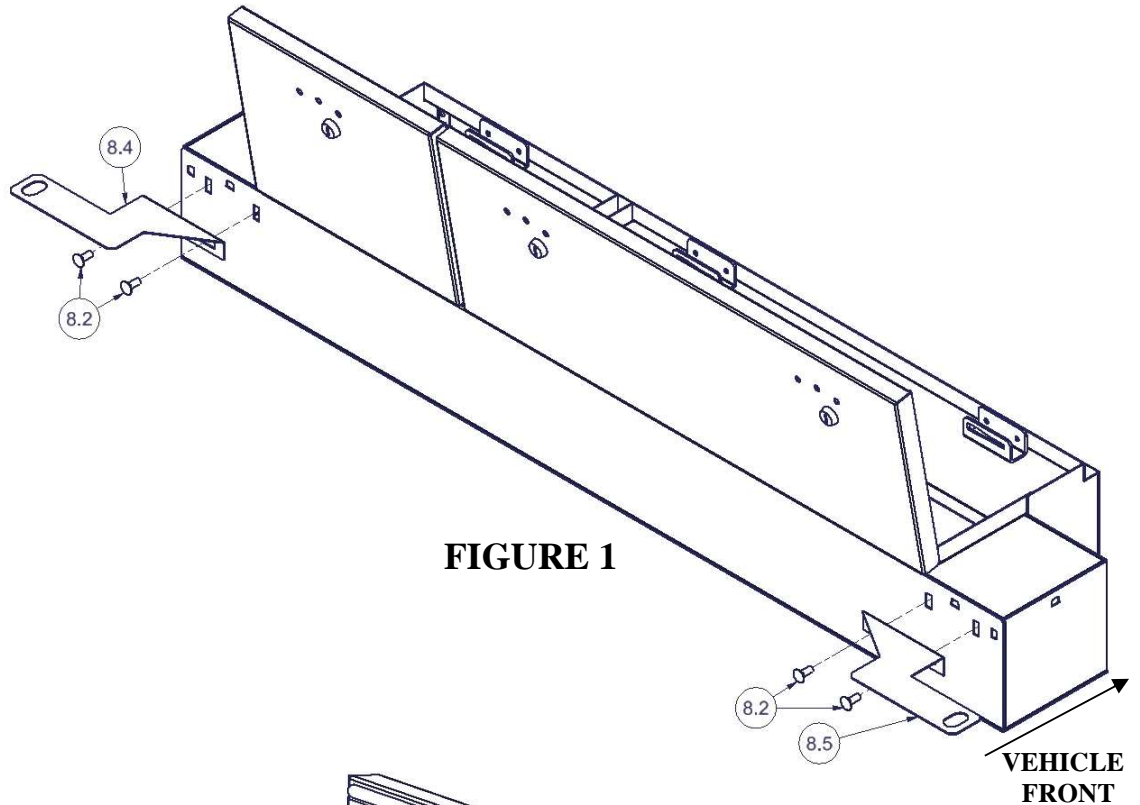

FIGURE 1

12. Insert the #8.2 Carriage bolts through the #8.4 and #8.5 Mounting Brackets so they protrude to the inside of the box. The Carriage bolts may need to be moved in the horizontal slots of the #8.4 and 8.5 Brackets to line up properly with the vertical slots in the rear of the Lockbox. See **Figure 1**

13. Install, **but do not tighten** the #8.3 Washers, and #8.1 Wing Knob Nuts. See **Figure 2** (Passenger side shown, driver side similar). **NOTE:** It may be necessary to hold the heads of the #8.2 Carriage bolts to prevent them from falling backward while starting the #8.1 Knob Nuts.

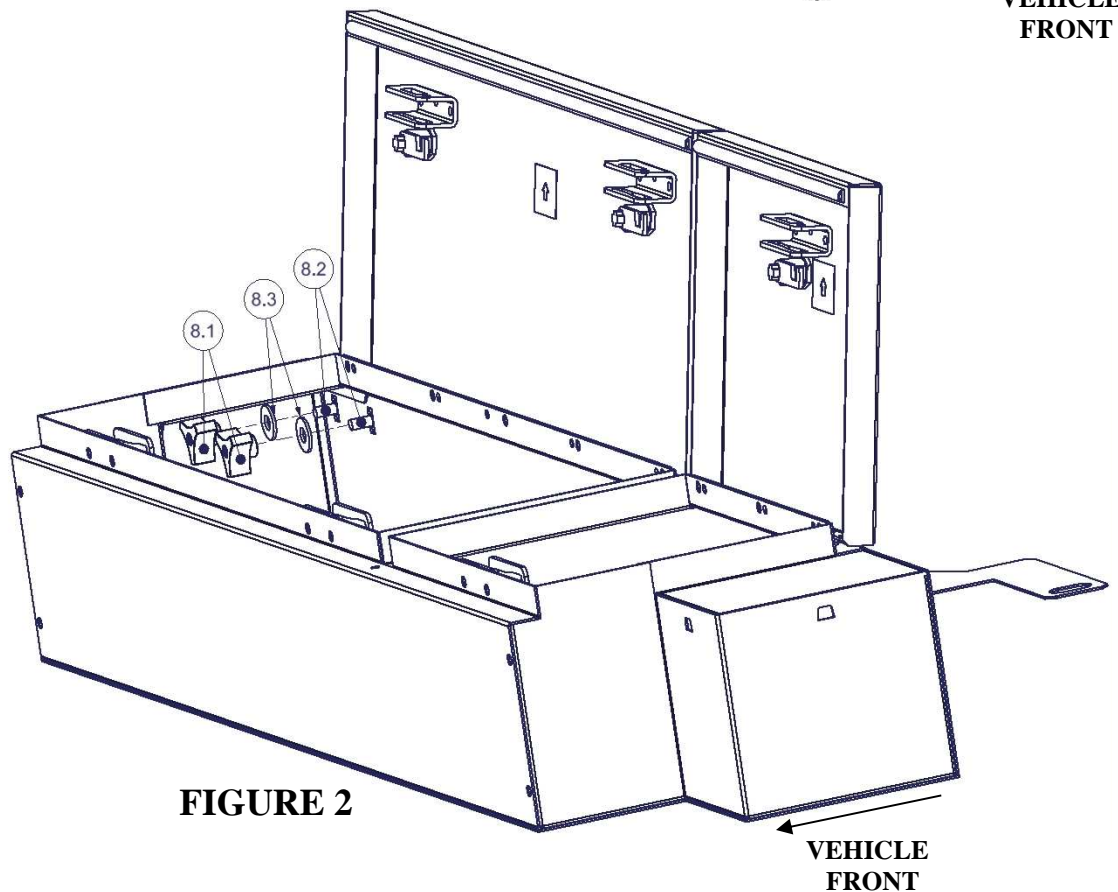

FIGURE 2

14. Adjust the Lockbox's side to side position so that the gap in the lids aligns with the rear seat split. This may be done by alternately opening the Lockbox lids and raising and lowering the rear seats and adjusting to eliminate interference.

15. Once the Lockbox is in its final position, the (4) #8.1 Wing Knob Nuts and the (2) Seat Mount Bolts may be tightened.