



INSTALLATION INSTRUCTIONS

2018+ Jeep JL Console Insert #348

PARTS CHECKLIST



#8 Left Fill Plate



#9 Right Fill Plate

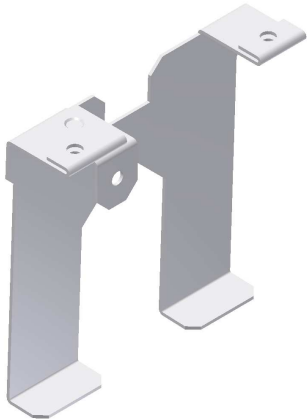

#10 Left Brace



#11 Right Brace

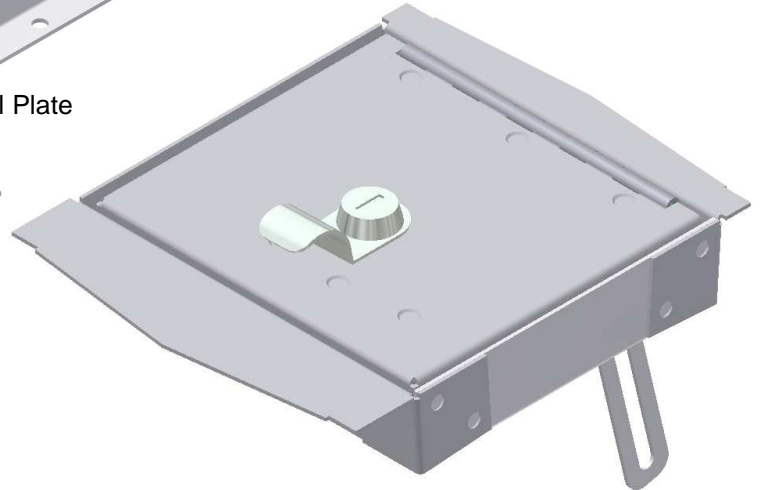

Console Insert #348

SHIPPING PACKAGE CONTENTS

(Included With Keys)

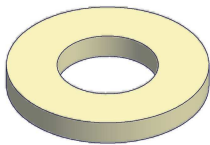

#13.1 (2)
1/4" Nylon Washer

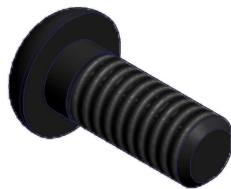

#13.2
1/4"-20 x 5/8" Cap Screw

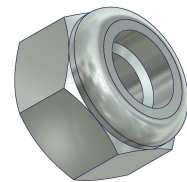

#13.3
1/4"-20 Nylock Nut

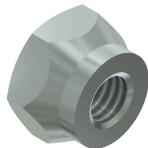

#13.4 (6)
#10-32 Nylock Nut

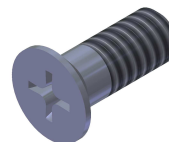

#13.5 (6)
#10-32 x 1/2" Screw

Tools needed for standard installation:

•Phillips Head Screwdriver

•5/32" Hex Wrench

•3/8" End Wrench

•7/16" End Wrench

PLEASE READ ALL INSTRUCTIONS THOROUGHLY BEFORE STARTING INSTALLATION.

1. Remove all contents from the shipping box and confirm that you have all the components listed on Page 1.
2. Open the factory console lid and remove all contents (including the pad in the bottom of the OEM console).
3. Place the #348 Console Insert into the OEM console with the lock toward the front of the vehicle. A slight downward angle may be required, as the opening of the console is smaller than the inner profile.
4. Unlock and open the lid of the #348 Console Insert and lift it off the bottom of the console and install the #8 Left Fill Plate using (1) #13.5 Screw, and (1) #13.5 Nylock Nut. The Fill Plate should be inserted through the opening of the Console Insert, and then lifted into position between the wall of the console and the outer edge of the Console Insert collar. (See Figure 1)

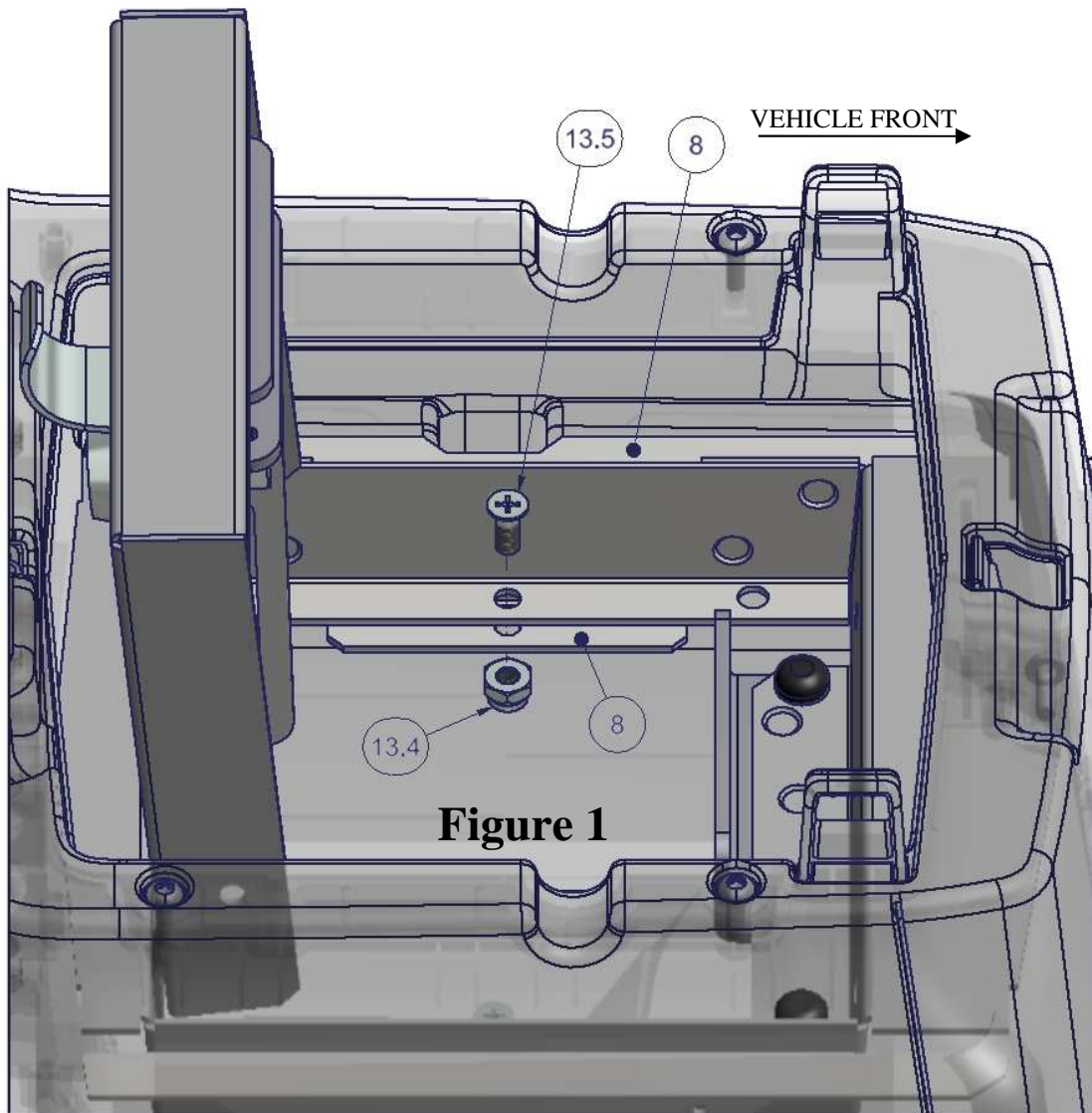

5. Install the #9 Right Fill Plate using (1) #13.5 Screw, and (1) #13.4 Nylock Nut. As with the left side, the Fill Plate should be inserted through the opening of the Console Insert, and then lifted into position between the wall of the console and the outer edge of the Console Insert collar. (See Figure 2) **NOTE:** Screw is installed upward to provide temporary clearance for the next steps.

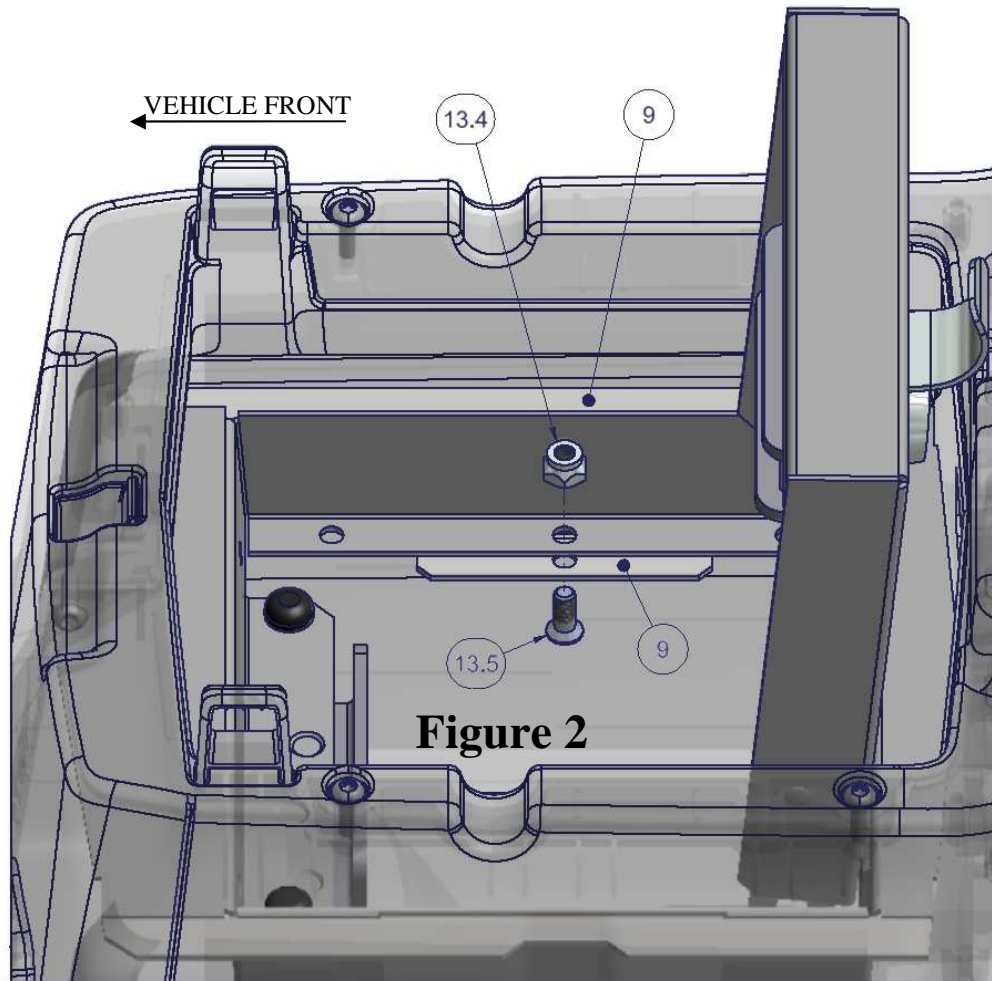

Figure 2

6. Move the #10 Left Brace into position by slipping the hem over the lower horizontal flange of the Console Insert collar and rotating it so the mounting holes align. (See Figures 3 and 4)

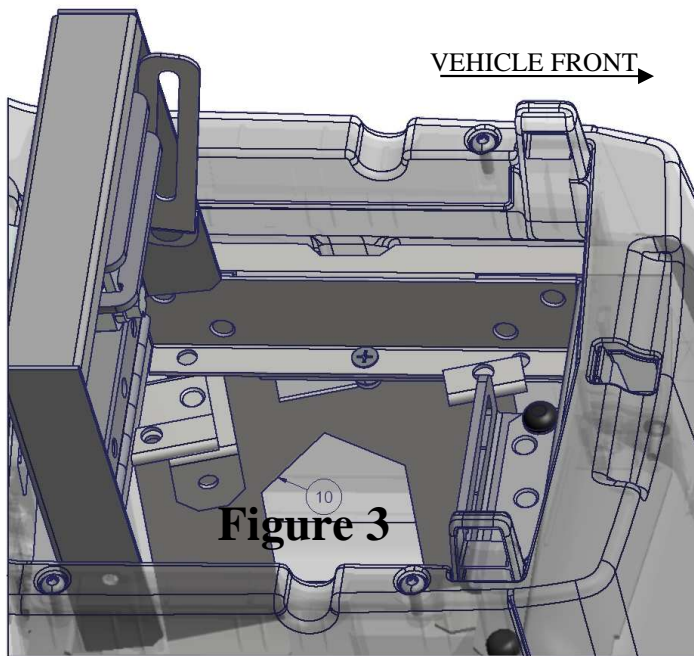

Figure 3

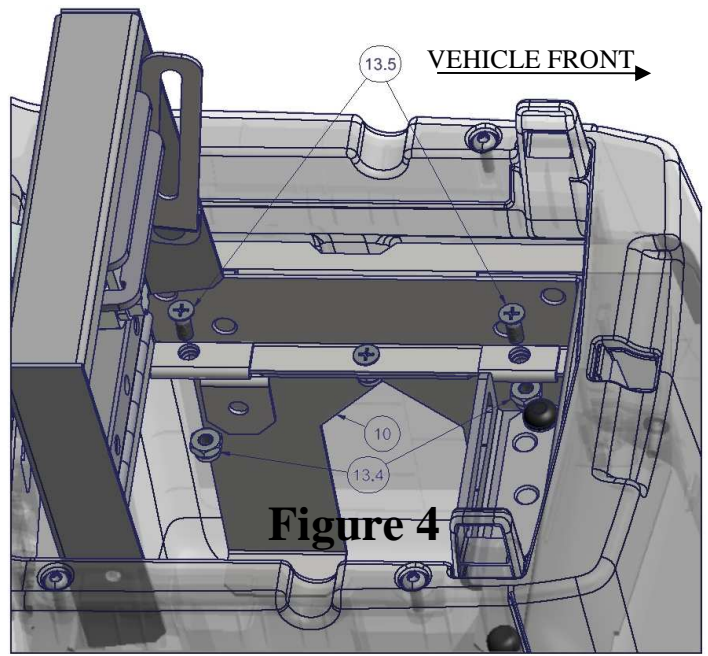

Figure 4

7. Install (2) #13.5 Screws and (2) #13.4 Nylock Nuts to secure the #10 Left Brace in position. (See Figure 4)

8. Move the #11 Right Brace into position by slipping the hem over the lower horizontal flange of the Console Insert collar and rotating it so the mounting holes align. (See Figures 5 and 6)

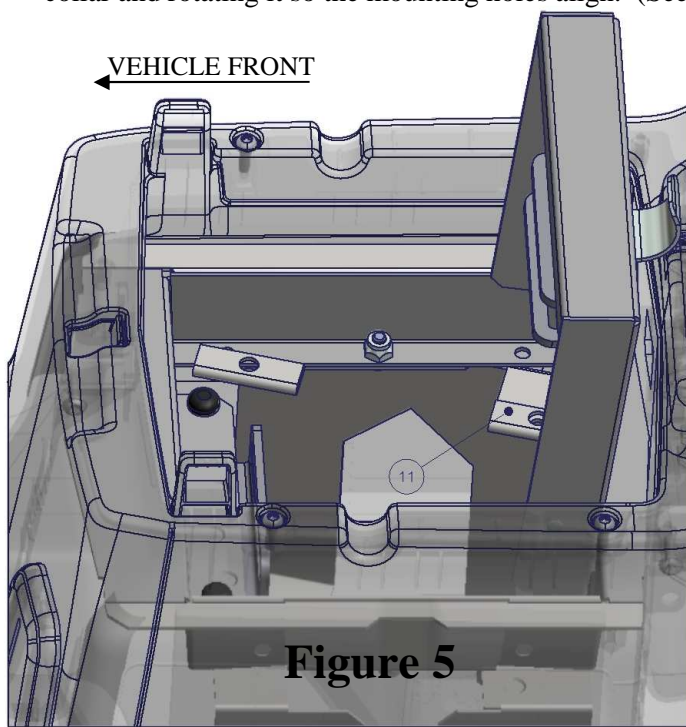

Figure 5

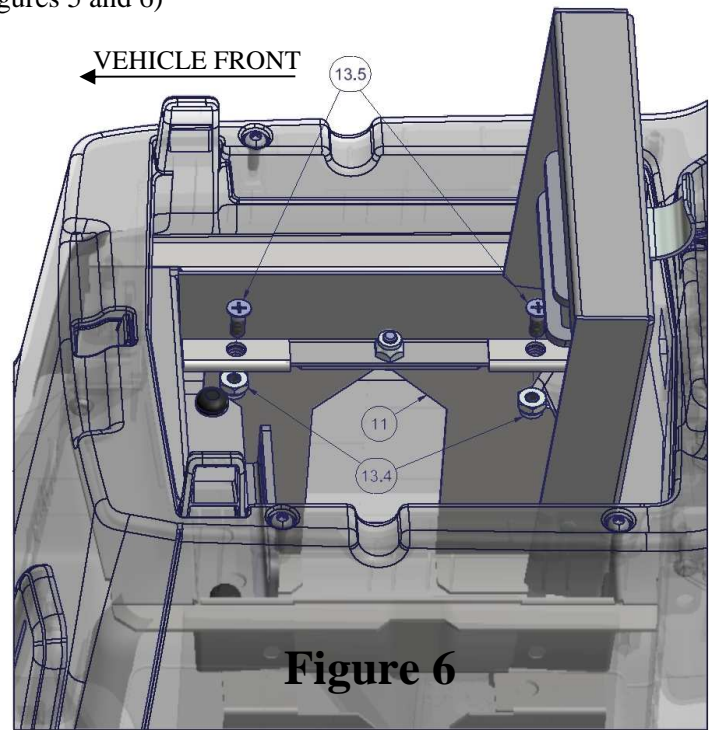

Figure 6

9. Install (2) #13.5 Screws and (2) #13.4 Nylock Nuts to secure the #11 Right Brace in position. (See Figure 6)
10. Remove the #13.5 Screw and #13.4 Nylock Nut holding the #9 Right Fill Plate in place and reorient them as shown in Figure 7.

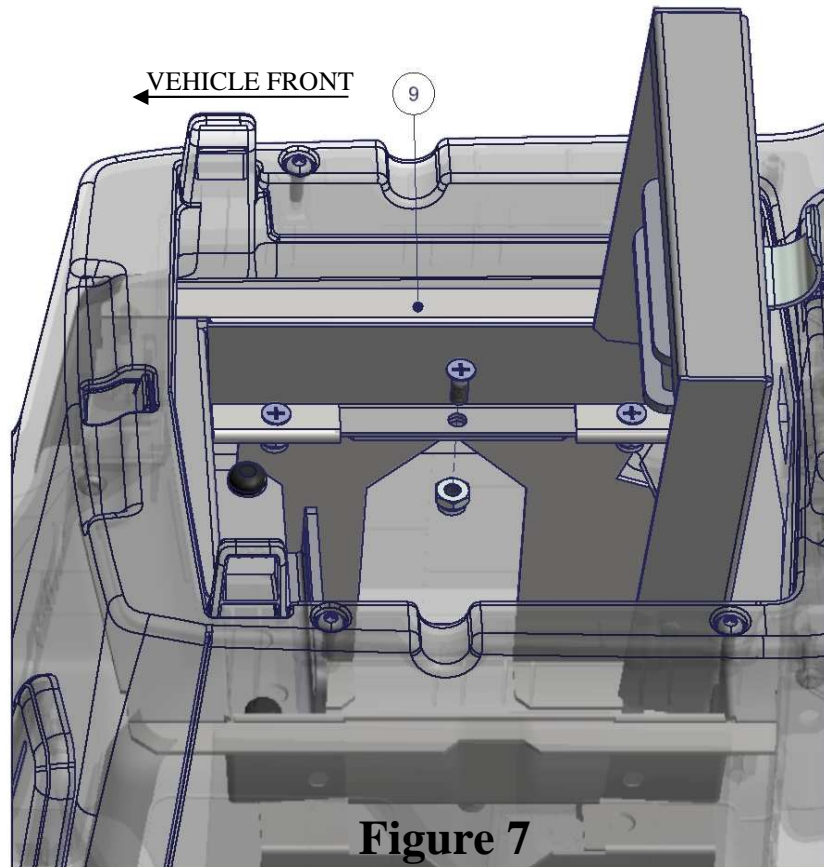
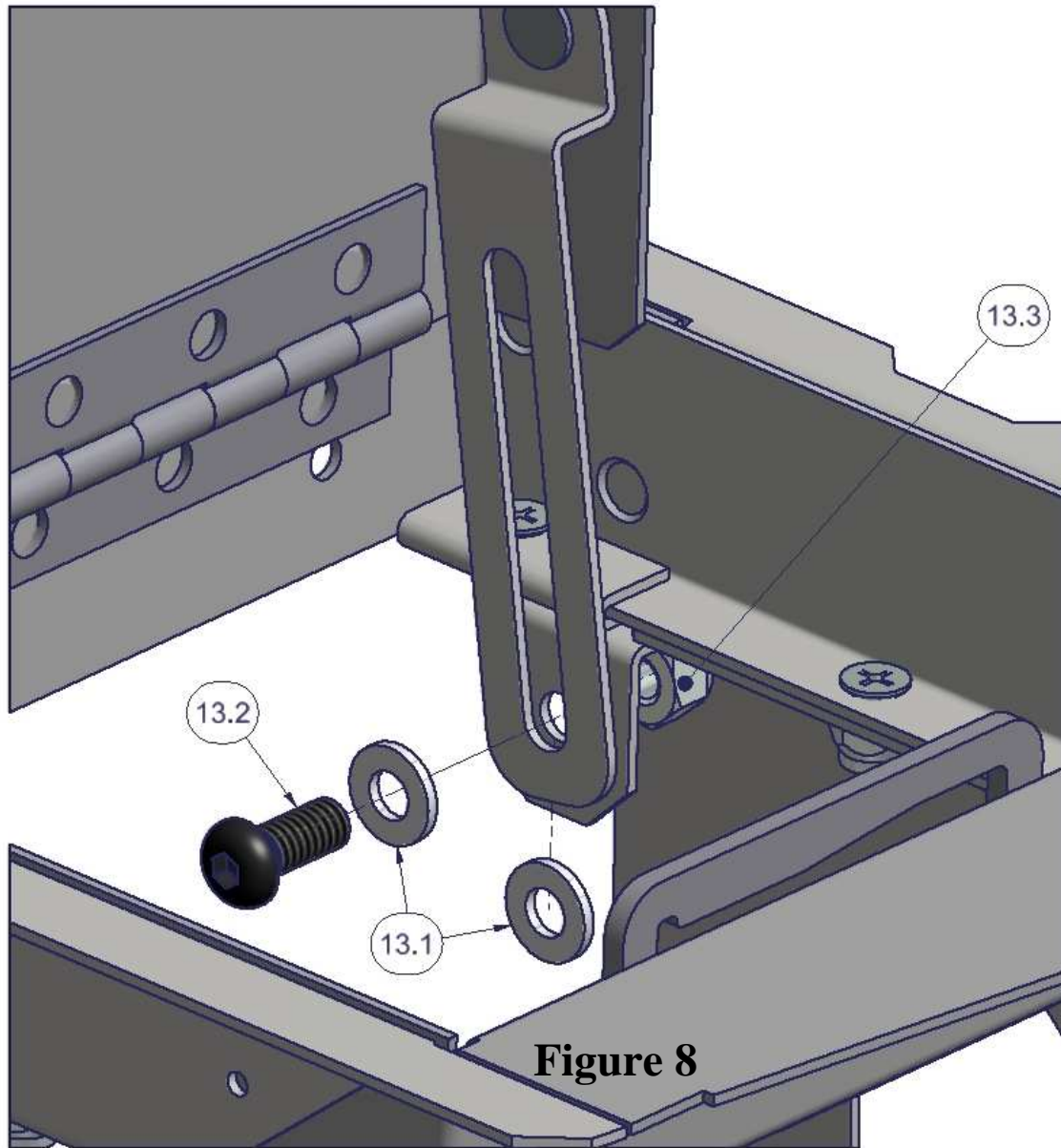

Figure 7

11. Assemble the lid support hardware as shown in Figure 8, using the #13.2 Cap Screw, #13.3 Nylock Nut, and (2) #13.1 Nylon Washers. Tighten the hardware in small increments so that the lid remains supported as you prefer (normally self-supporting at a 45-degree lid angle).



NOTE: Second nylon washer (#13.1 shown below assembly in Figure 8) slips between moving slotted part, and stationary body.

NOTE: Over time the friction that holds the lid in the open position may be reduced due to normal wear. To increase the friction, it is necessary to tighten the assembly. Tighten in small increments and test by opening/closing the lid until you have reached your preferred tension.

12. Confirm that all hardware has been sufficiently tightened.
13. Replace contents of console, the pad removed in Step 2 will cover the bottoms of the braces.