

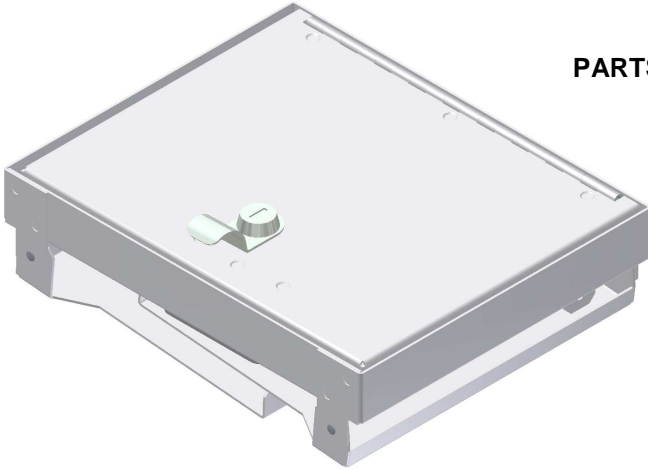


# INSTALLATION INSTRUCTIONS

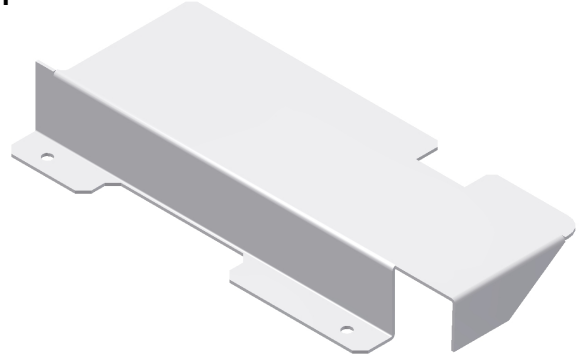
## 2011-2016 Ford Super Duty Console Insert #322

Fits Trucks with Flow-Thru Console

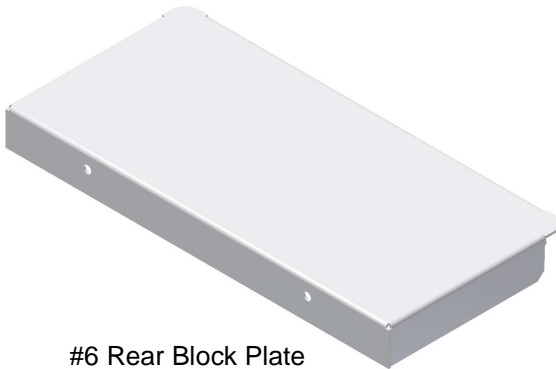
### PARTS CHECKLIST



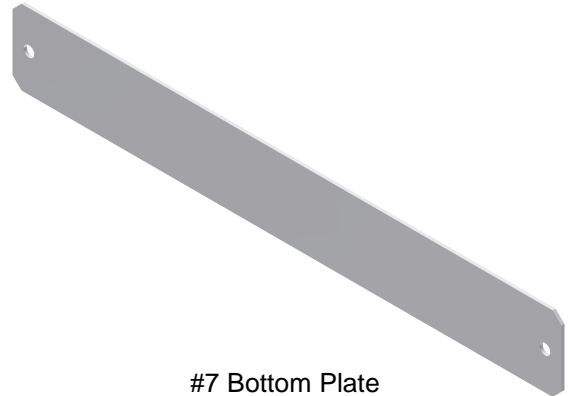
Console Insert #322



#5 Front Block Plate



#6 Rear Block Plate



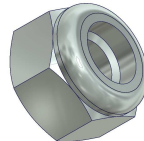
#7 Bottom Plate

### SHIPPING PACKAGE CONTENTS

(Included In Key Bag)



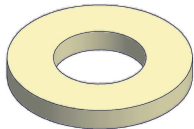
#12.1 (4)  
#10-32 x 3/16" Screw



#12.2  
1/4"-20 Nylock Nut



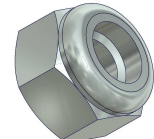
#12.3  
1/4"-20x5/8" Cap Screw



#12.4 (2)  
1/4" Nylon Washer



#12.5 (4)  
#10-32 x 1/2" Screw



#12.6 (4)  
#10-32 Nylock Nut

#### Tools needed for standard installation:

•Phillips Head Screwdriver

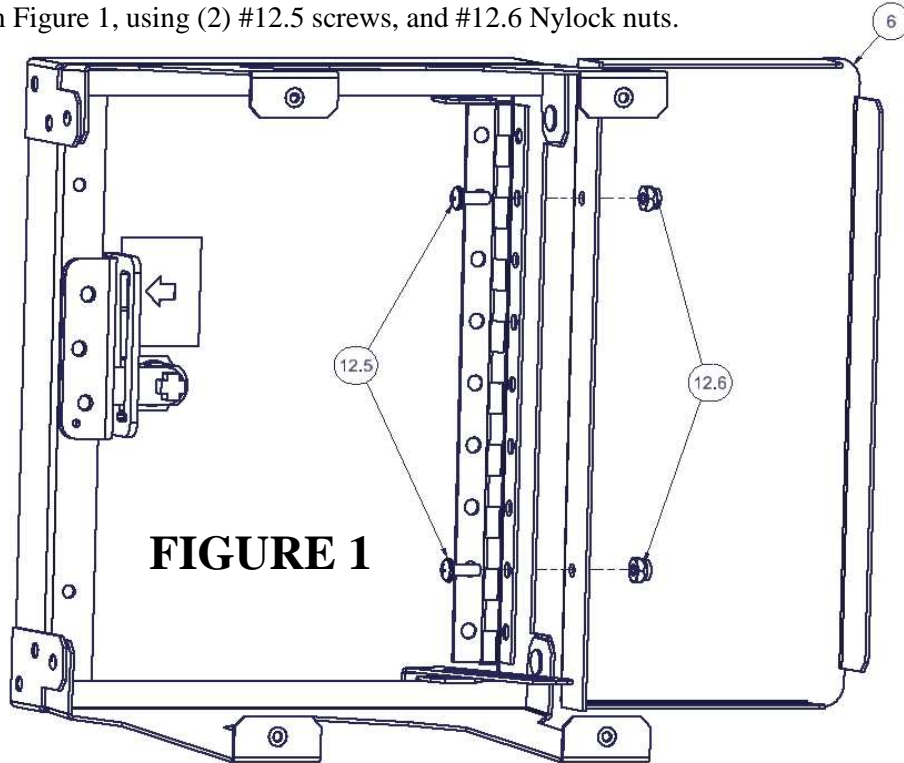
•3/8" Wrench/Socket

•5/32" Hex Wrench

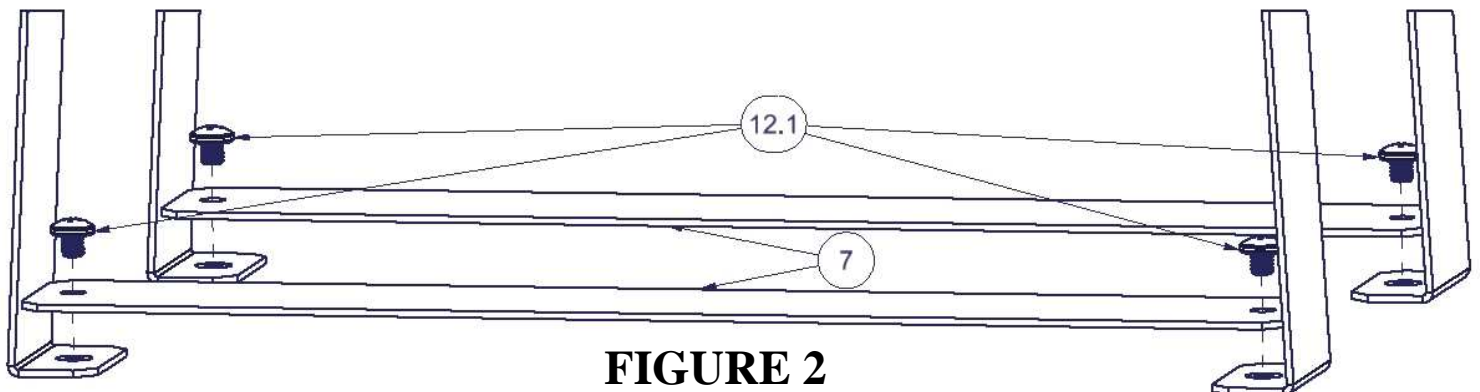
•7/16" End Wrench

**PLEASE READ ALL INSTRUCTIONS THOROUGHLY BEFORE STARTING INSTALLATION.**

1. Remove all contents from the shipping box and confirm that you have all of the components listed on Page 1.
2. Remove the contents of the factory console, including the factory coin tray, removable tray supports, and bottom mat.
3. Invert the #322 Console Insert so it rests on its lid, expand the legs and attach the #6 Rear Block Plate to the main body as shown in Figure 1, using (2) #12.5 screws, and #12.6 Nylock nuts.



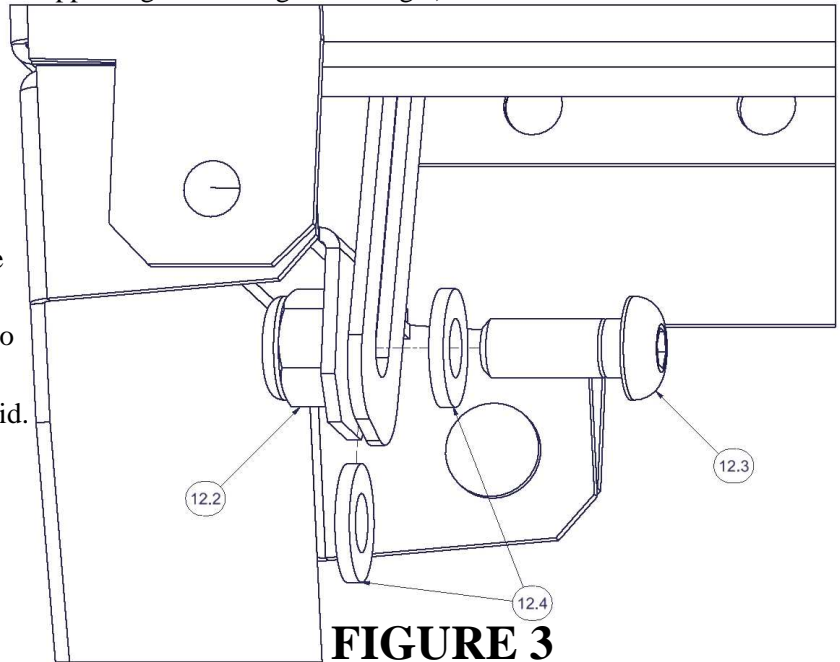
4. Return the Insert legs to the shipping position, remove the backing from the double sided tape squares on the rear edge of the #6 Rear Plate, and insert the assembly into the console, so that the lid is up and the lock is toward the front of the vehicle.
5. Open the lid, and lift the console into position by spreading the legs so that they meet the sides of the console, slide the Insert to the back of the console so that the tape squares adhere to back edge of console. Forward edge of insert should be very near the 12V Power Port housing.
6. Attach the #7 Bottom Plates to the assembly using (4) #12.1 Screws, as shown in Figure 2.



- Assemble the lid support hardware, as shown in Figure 3. Tighten the hardware in small increments so that the lid remains supported as you require (usually self-supporting at a 45 degree lid angle).

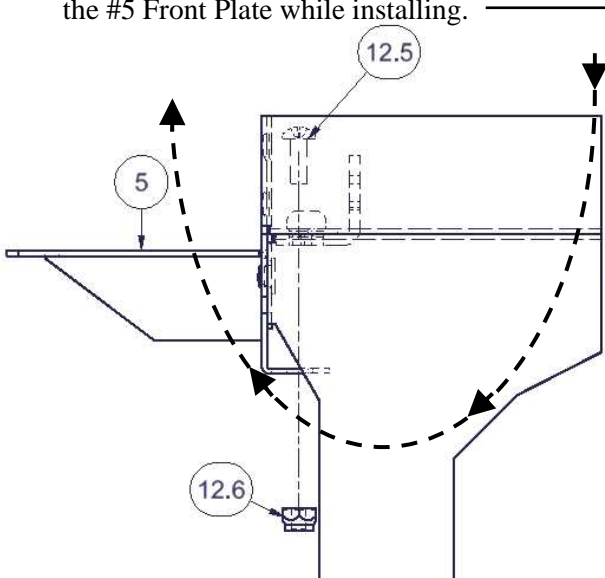
NOTE: Second nylon washer (#12.4 shown below assembly in Figure 3) slips between moving slotted part, and stationary body.

NOTE: Over time the friction that holds the lid in the open position may be reduced as a result of use, and it may become necessary to tighten the assembly. Tighten in small increments and test by opening/closing the lid.

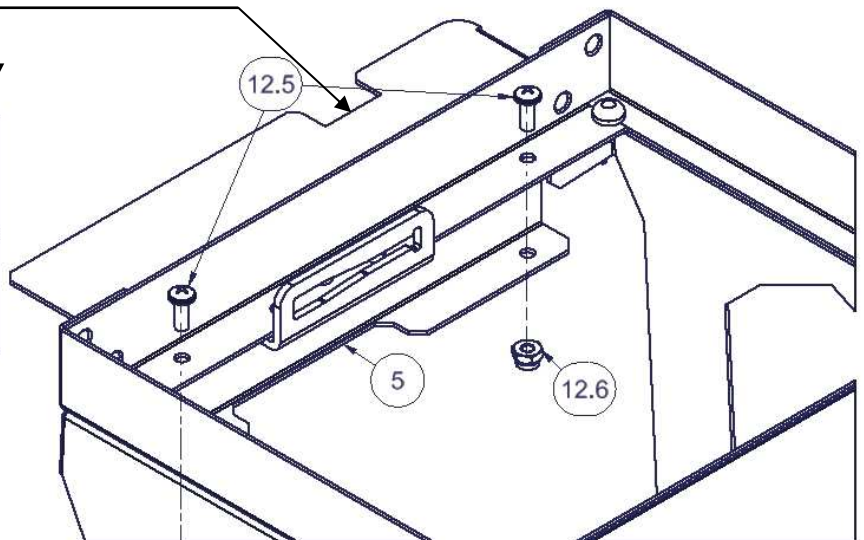


**FIGURE 3**

- Position the #5 Front Plate toward the front of the insert from inside the console and secure it to the main body using (2) #12.5 screws, and (2) #12.6 Nylock nuts as shown in Figure 4a/b. NOTE: If you wish to run a semi-permanent power cord to the interior of the console for secure charging within the insert, place it in the middle of the cutout in the #5 Front Plate while installing.



**FIGURE 4a**



**FIGURE 4b**  
**(Lid Removed for Clarity)**

- Replace the contents of the console starting with the bottom mat (removed in Step 2) to cover the screw heads and bottom plates. NOTE: The unsecured flat area behind the Insert lid has been sized to accommodate the factory rubber coin tray insert. The factory coin tray and tray supports cannot be used in conjunction with the Console Insert and should be stored if you wish to return the console to factory original condition.