



INSTALLATION INSTRUCTIONS

2010+ Ram Truck Console Insert #321

Fits Trucks with Flow-Thru Console Without Remote CD Player

PARTS CHECKLIST



#3 (2) Bottom Plate
(In Bottom of Shipping Box)

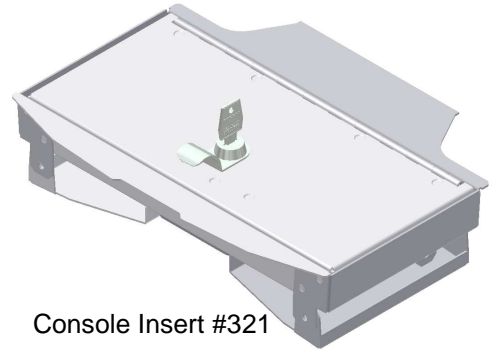

Console Insert #321

SHIPPING PACKAGE CONTENTS

(Included With Keys)



#11.1 (4)
#10-32 x 3/16" Screw

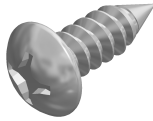

#11.2 (4)
#12x5/8" Screw

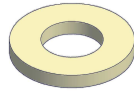

#11.3.3 (2)
1/4" Nylon Washer



#11.3.2
1/4"-20x5/8" Cap Screw

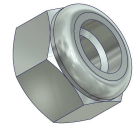

#11.3.1
1/4"-20 Nylock Nut

Tools needed for standard installation:

•Phillips Head Screwdriver

•5/32" Hex Wrench

•7/16" End Wrench

PLEASE READ ALL INSTRUCTIONS THOROUGHLY BEFORE STARTING INSTALLATION.

1. Remove all contents from the shipping box and confirm that you have all of the components listed above.
2. Unlock the lid of the #321 Console Insert and rest on a flat surface, open the lid, expand the legs and attach the #3 Bottom Plates to the main body as shown in Figure 1, using (4) #11.1 screws.

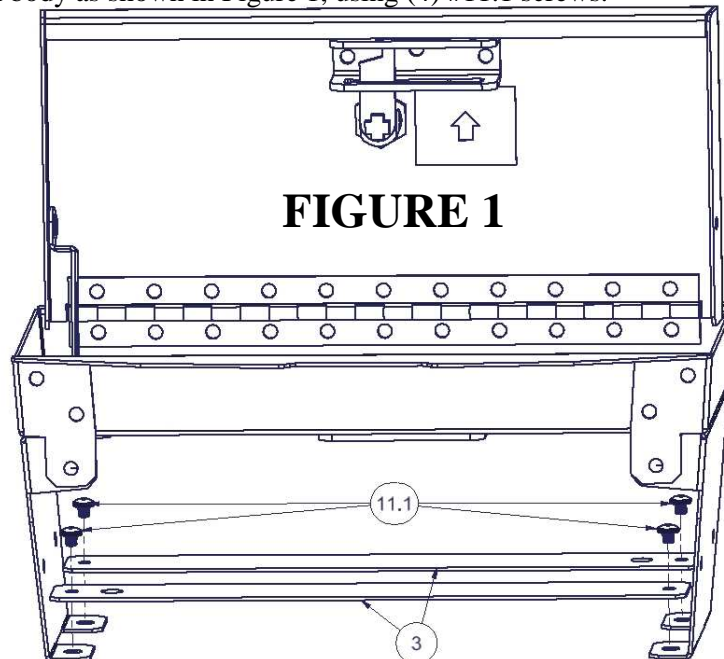

FIGURE 1

3. Assemble the lid support hardware, as shown in Figure 2. Tighten the hardware in small increments so that the lid remains supported as you require(usually self-supporting at a 45 degree lid angle).

NOTE: Second nylon washer (#11.3.3 shown below assembly in Figure2) slips between moving slotted part, and stationary body.

NOTE: Over time the friction that holds the lid in the open position may be reduced. To increase the friction it is necessary to tighten the assembly. Tighten in small increments and test by opening/closing the lid.

FIGURE 2

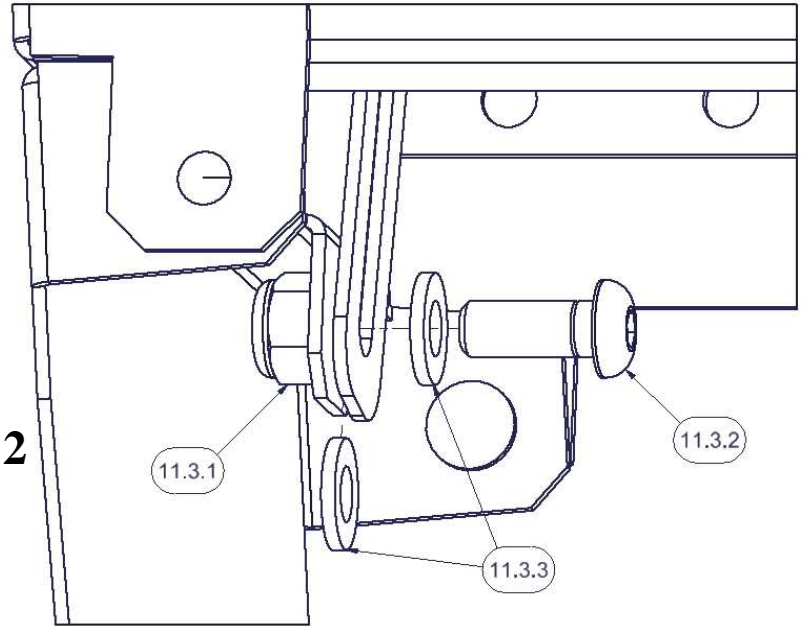

4. Remove the mat in the bottom of the factory console(set aside for reinstallation), and lower the 321 Console Insert into place.
5. While applying downward pressure on the Insert, mark the centers of the mounting holes in the legs. Remove the Insert and use one of the #11.2 screws and a screwdriver to “drill” holes in the plastic console interior.
6. Replace the Console Insert into position and install the (4) #11.2 screws that secure it in place(Figure 3).

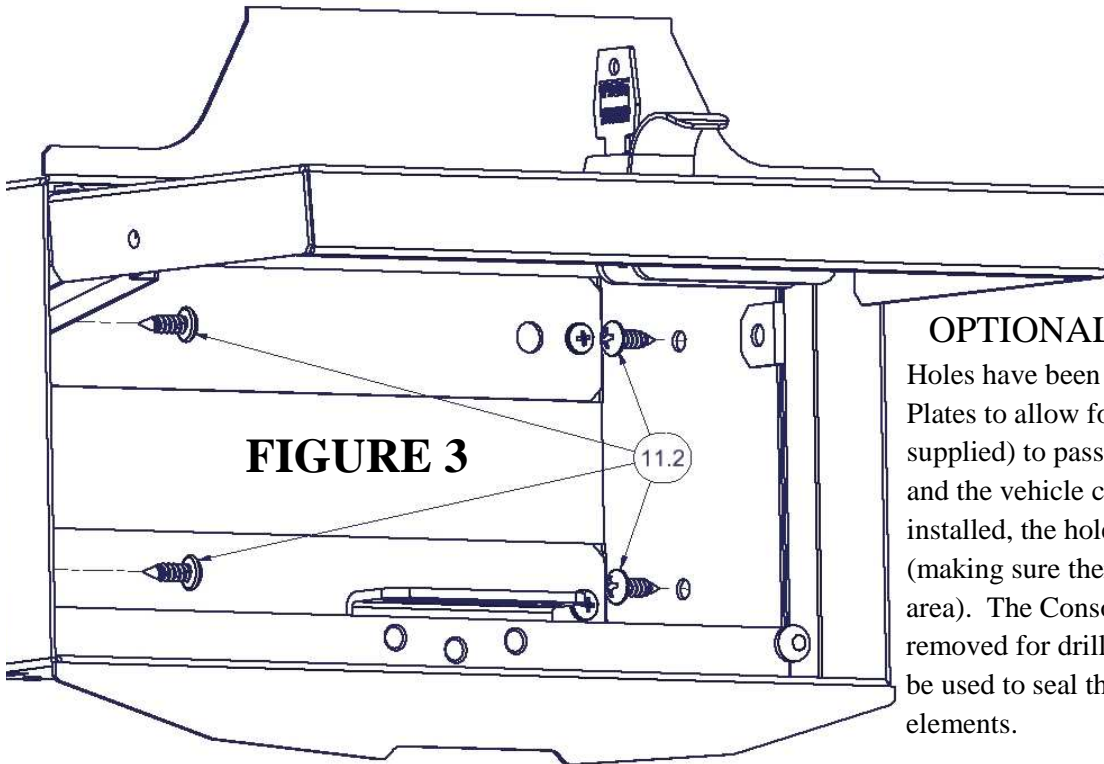

FIGURE 3

OPTIONAL SECURITY STEP:

Holes have been provided in the #3 Bottom Plates to allow for (2) 5/16” bolts(user supplied) to pass through the console body and the vehicle cab. Once the Insert is installed, the holes can be marked and drilled (making sure there are no wires/hoses in the area). The Console Insert may need to be removed for drilling. Silicone sealant should be used to seal the exterior from the elements.

7. Reinsert the Bottom Mat(removed in Step 4) to cover the screw heads and bottom plates.