

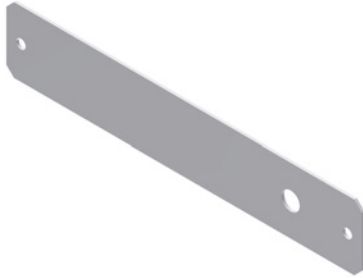

# INSTALLATION INSTRUCTIONS

2014+ Silverado/Sierra [Console Insert #320](#)



#11 (2) Bottom Plate  
(In Bottom of Shipping Box)

## PARTS CHECKLIST



Console Insert #320

## SHIPPING PACKAGE CONTENTS

(Included With Keys)



#14.2 (4)  
#10-32 x 3/16" Screw

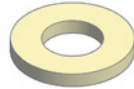

#14.3 (2)  
1/4" Nylon Washer



#14.4  
1/4"-20x5/8" Cap Screw

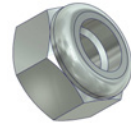

#14.5  
1/4"-20 Nylock Nut

### Tools needed for standard installation:

•Phillips Head Screwdriver

•5/32" Hex Wrench

•7/16" End Wrench

### PLEASE READ ALL INSTRUCTIONS THOROUGHLY BEFORE STARTING INSTALLATION.

1. Remove all contents from the shipping box and confirm that you have all of the components listed above.
2. Unlock the lid of the #320 Console Insert and rest on a flat surface, open the lid and assemble the lid support hardware as shown in Figure 1. Tighten the hardware in small increments so that the lid remains supported as you require. After assembling this hardware the Console Insert will no longer fully collapse to its original shipping size, do not attempt to force it closed.

NOTE: Second nylon washer(#14.3 shown below assembly in Figure1) slips between moving slotted part, and stationary body.

NOTE: Over time the friction that holds the lid in the open position may be reduced. To increase the friction it is necessary to tighten the assembly. Tighten in small increments and test by opening/closing the lid.

### FIGURE 1

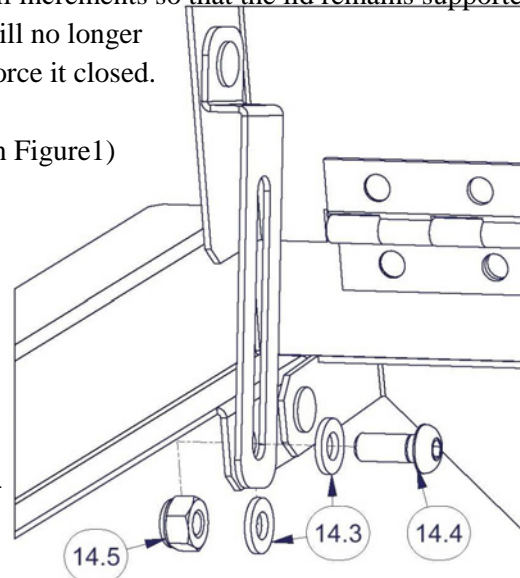

3. Open the factory console lid and remove the #1 Hanging Folder Supports on either side of the console by sliding them forward, and then toward the center of the console. See Figure 2

4. Remove the #2 Forward Bin by lifting it vertically with one hand on each side of the underside of the bin.
5. Lift out the #3 Bottom Mat and set aside with the other removed factory components.

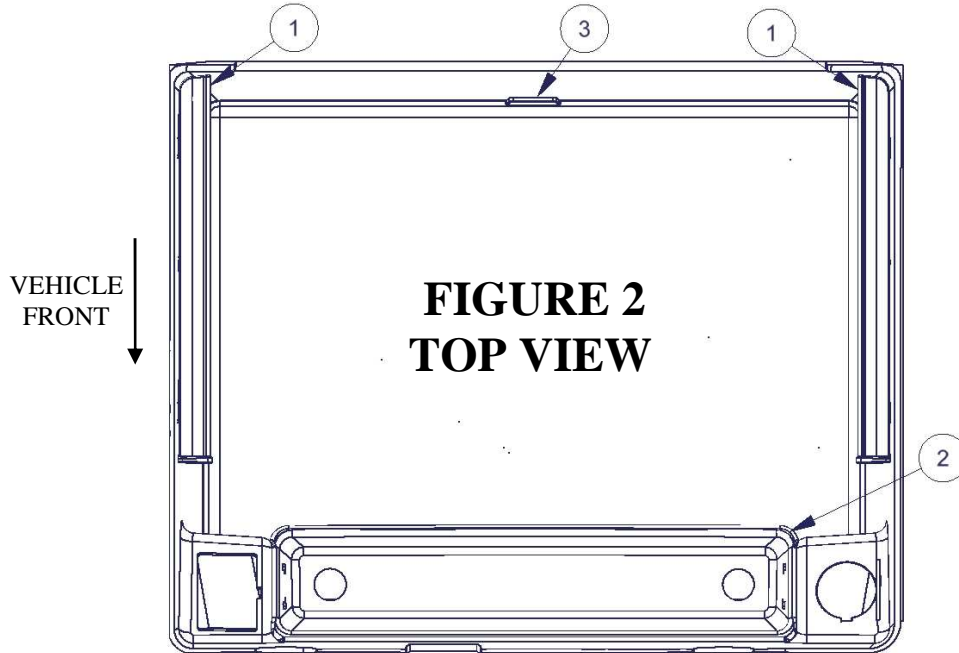

6. Using a 10mm socket remove the (2) #4 Factory Console Mounting Bolts shown in Figure 3.

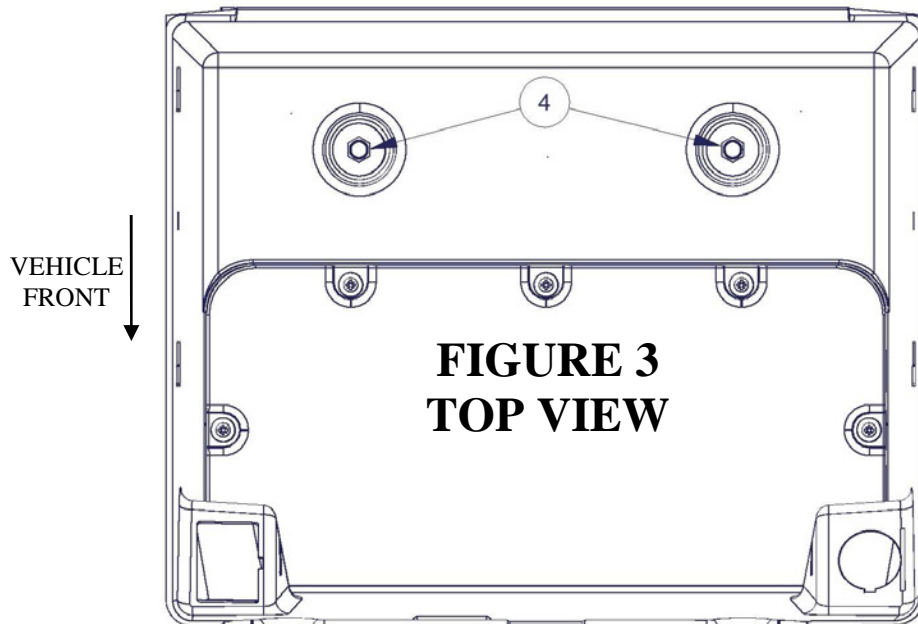

7. Insert the partially collapsed #320 Console Insert into the console by tipping the forward edge down slightly and rotating it into place as shown in Figure 4.
8. Rotate the forward leg down into position so that the angled portion of the upper leg rests against the housings for the USB ports and 12V power port.
9. Move the rear leg so that its feet rest on the bottom of the console and its back edge is flush with the rear of the console interior.

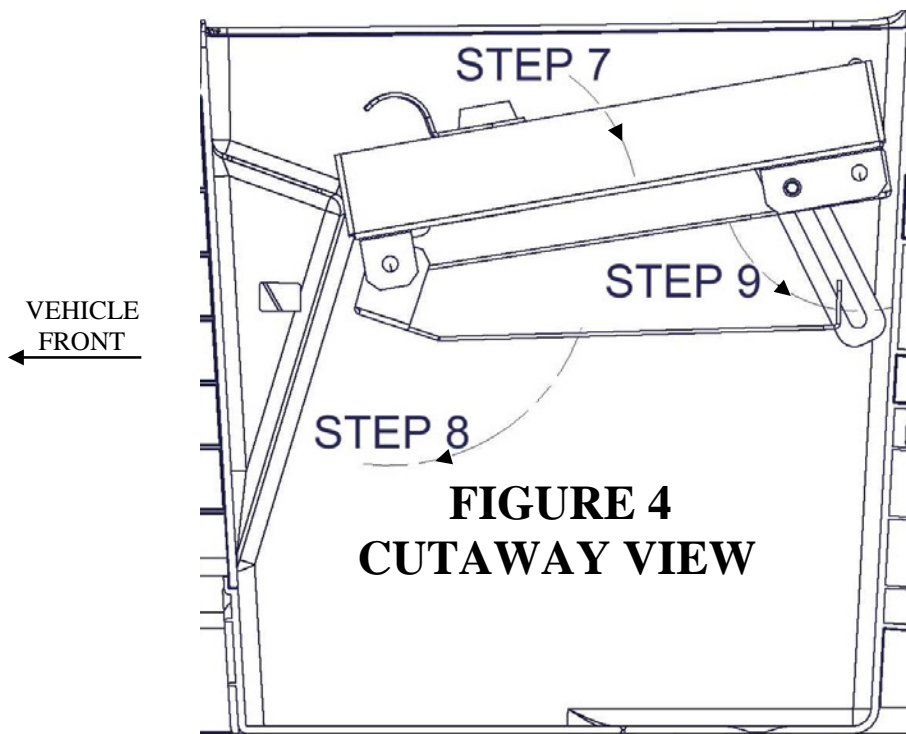

10. Insert the (2) #11 Bottom Plates into the bottom of the console and install them using (4) #14.2 Machine Screws, as shown in Figure 5, starting with the (2) forward Screws. Due to the angle of the Insert legs, it is easiest to start the #14.2 Machine Screws by hand and finish tightening them with a screwdriver.

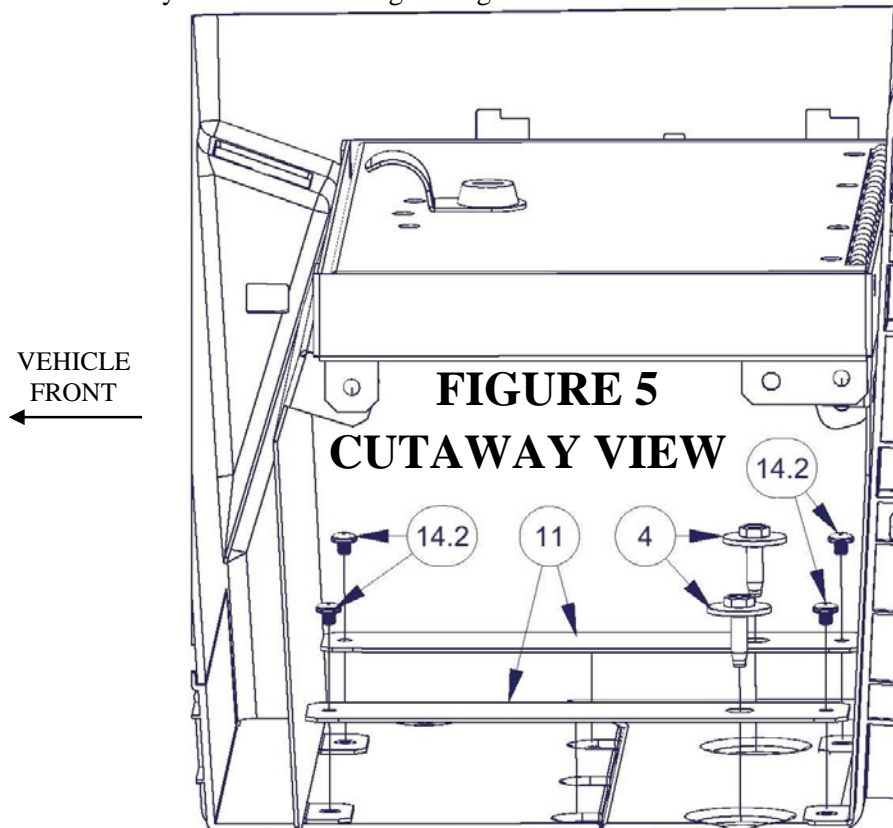

11. Reinstall the (2) #4 Console Mounting Bolts (removed in Step 6) in the factory locations and tighten to about 4 ft-lbs, or until the bottom of the #11 Plates meet the bottom surface of the console in the area around the concave inset.  
NOTE: If you wish to cover the hardware in the bottom of the console, a piece of carpet or mat 12" x 8" may be used.