



INSTALLATION INSTRUCTIONS

#285, Ford F150 Extended cab, [under rear seat lockbox](#), with and w/o subwoofer

PARTS CHECKLIST



LOCKBOX #285



#5 MOUNTING BRACKET



#9.8 (3) 8MM X 25MM BOLT



#9.9 (3) 5/16" WASHER



#9.7 (2) 1/4-20 X 3/4 BOLT

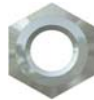

#9.4 (2) 1/4-20 NUT



#9.5 (4) 1/4" WASHERS

Tools needed for standard installation

- 10mm Socket and Ratchet
- 13mm Socket and Ratchet
- 7/16" Socket and Ratchet
- 7/16" Wrench

PLEASE READ ALL INSTRUCTIONS THOROUGHLY BEFORE STARTING INSTALLATION.

1. Flip both rear seats up so they are secured in the upright position.
2. Install the #5 mounting bracket using the illustrated hardware to the OEM seat bracket #9.6. If the vehicle is equipped with a subwoofer use the original OEM mounting bolt to fasten the #5 bracket instead of the hardware provided. (See Figure 1)
3. Remove the jack from the #9.1 jack mounting plate. Consult your Ford owner's manual for removal instructions. (See Figure 1)
4. Remove the (3) #9.2 OEM original mounting bracket bolts securing the #9.1 jack mounting bracket to the vehicle. Leave the Jack mounting plate #9.1 in the original location (See Figure 1)

Figure 1

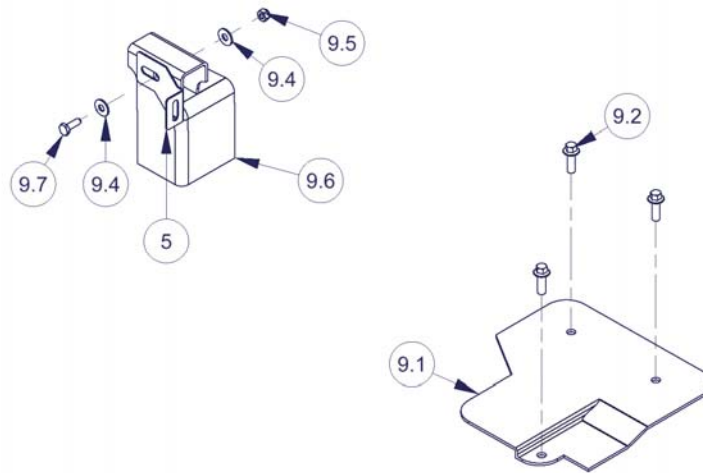

5. Place the lockbox in the vehicle on top of the #9.1 jack mounting plate. (See Figure 2)
6. Fasten the lockbox to the top of the jack mounting plate using the #9.8 bolts and #9.9 washers. When tightening this hardware the mounting brackets will bend to conform to the shape of the jack mounting plate. (See Figure 2)
7. Fasten the side of the lockbox to the #5 mounting bracket using the illustrated hardware. (See Figure 2)
8. Reinstall the jack into the #9.1 jack mounting plate. (See Figure 2)
9. Check the lock operation.

Figure 2

