



INSTALLATION INSTRUCTIONS

082 [COMBO LOCK](#)

Instructions for setting personal combination & installation

Attention: The combination lock is shipped from the factory set with the code >0-0-0< and will need to be reset by the customer.

Setting personal combination

1. The combination must be set to the current open number prior to resetting (Factory setting is >0-0-0<)
2. On the underside outer edge of the lock there is a hole for the code reset button. Rotate the face of cam until the code reset button comes into view.
3. Push this pin in with a paperclip and keep it pushed in.
4. Set personal combination by turning dials to desired combination
5. Release the reset button and your combination is set.
6. To lock, rotate lock to "locked" position. Rotate one or more dials after lock is closed. To open lock, turn dials to personal combination.

Note: If desired, lock can be installed as non-resettable combination. Take off the screw #6 and remove the cam #4 & "stop cam" #5. Rotate cylinder 180 degrees & put "stop cam" #5 & cam #4 back on. This covers up the pin used for resetting the combination.

Installing the lock

Note: See Figure 1 for the standard configuration for #247 - TUFFY JK CONCEAL CARRY SECURITY DRAWER, See Figure 2 for a typical Cam lock Security Box configuration.

Note: There is a small "Stop Cam" #5 behind the large rotating hooked lock cam #4 which can be moved to any of four different positions which allow the rotation of the lock to be reversed or adjusted so the combinations are easier viewed for different angles. To change, remove the screw #6 holding the large hook cam #4 to the back of the lock then remove the hook cam to access the "Stop Cam" #5 and adjust the stop cam and the hooked lock cam together as required to produce the desired lock operation. This will allow you to customize the orientation of the combination dials for the easiest viewing and operation for your application. (See Figure 1 and 2 for examples)

1. Remove the old lock by unfastening the large nut #3 securing it to the face then maneuvering it through the hole.
2. After resetting the combination, take note of the arrow and the cam location in the unlocked and locked positions. Figure 1 shows the lock and cam in the standard locked position with the arrow and cam facing up (rotates 90 degrees counterclockwise to open). See **Notes** above for optional installations on setting the combo lock at different orientations for your applications.
3. Remove the cam, and insert the lock into the mounting hole. (See Figure 1 or Figure 2)
4. Fasten the lock to the face using the nut #3 included. (See Figure 1 or Figure 2)
5. Check to make sure it rotates correctly into the locking mechanism.

FIGURE 1

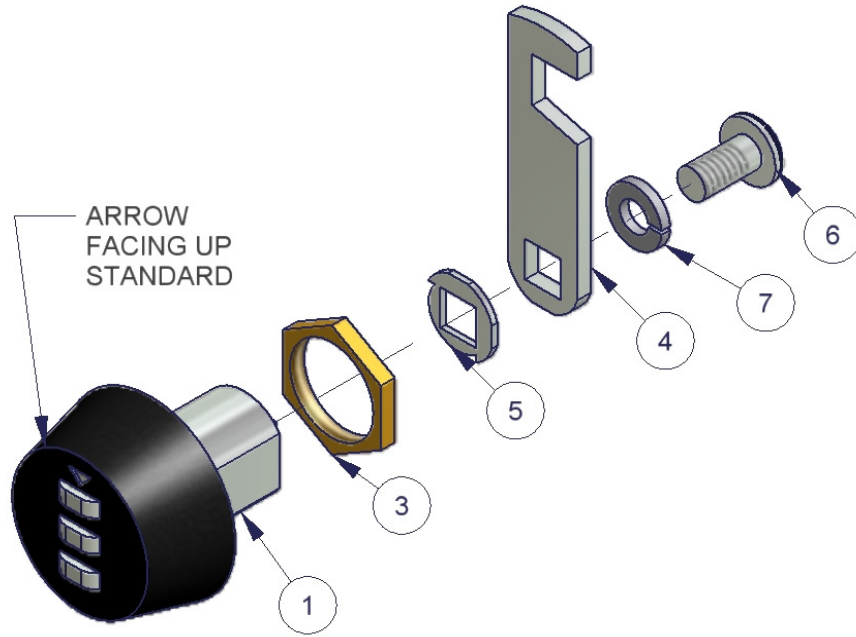

FIGURE 2

