

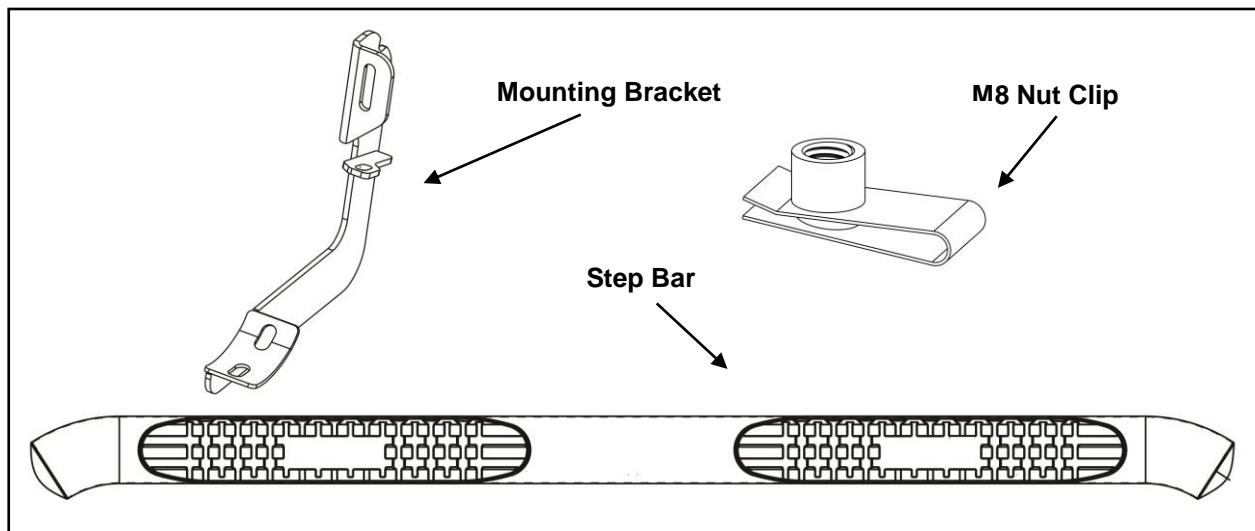

4" OVAL BEND STEP BARS ROCKER PANEL MOUNT
2015 1500 SILVERADO/SIERRA DOUBLE CAB / CREW CAB
2015 2500 / 3500 DOUBLE CAB / CREW CAB
EXCLUDES DIESEL

PARTS LIST:

2	STEP BARS		
6	MOUNTING BRACKETS		
24	M8 HEX HEAD CAP SCREWS		
24	M8 FLAT WASHERS		
24	M8 LOCK WASHERS		
12	M8 NUT CLIPS		



PROCEDURE:

REMOVE CONTENTS FROM BOX. VERIFY ALL PARTS ARE PRESENT. READ INSTRUCTIONS CAREFULLY BEFORE STARTING INSTALLATION. ASSISTANCE IS RECOMMENDED.

DOUBLE CAB

1. Starting at the driver's side of the vehicle locate the existing circular hole in the rocker panel towards the front of the vehicle, see Figure 4 and 5. Remove the rubber plug from the bigger hole to access the smaller diameter hole and insert (1) M8 nut clip over the hole, attach (1) mounting bracket to the previously installed nut clip using (1) M8 hex head cap screw, (1) M8 lock washer, and (1) M8 flat washer. Locate the existing hole in the pinch weld and place (1) M8 clip nut onto the hole, attach the mounting bracket to the pinch weld using (1) M8 flanged hex cap screw, and (1) M8 toothed lock washer, see Figure 6. Do not fully tighten at this time.
2. Repeat step 1 for the center and rear mounting brackets.
3. Take the driver's side step bar and place it on the mounting cradles then attach the step bar using (6) M8 button head cap screws, (6) M8 toothed lock washers, and (6) M8 flat washers, see Figure 7.
4. Align and adjust as needed then tighten all hardware at this time. Torque all M8 hardware to 15-20 ft-lbs.
5. Follow the same steps to install the passenger side mounting brackets and step bar.

CREW CAB

1. Starting from the driver's side of the vehicle locate the threaded hole located in the rocker panel towards the front of the vehicle, see Figure 1. Take (1) mounting bracket and attach it to the threaded hole using (1) M8 hex head cap screw, (1) M8 lock washer, and (1) M8 flat washer. Locate the existing

- welded nut on the pinch weld and attach the mounting bracket to the pinch weld using (1) M8 flanged hex cap screw, and (1) M8 toothed lock washer, see Figure 2. Do not fully tighten at this time.
- Repeat step 1 for the center mounting bracket. **Note: 2500 and 3500 do not have welded nut on pinch weld area reference double cab installation.**
 - Locate the existing circular hole in the rocker panel towards the rear of the vehicle, see Figure 3-5. Remove the rubber plug from the bigger hole to access the smaller diameter hole and insert (1) M8 nut clip over the hole, attach (1) mounting bracket to the previously installed nut clip using (1) M8 hex head cap screw, (1) M8 lock washer, and (1) M8 flat washer. Locate the existing hole in the pinch weld and place (1) M8 clip nut onto the hole, attach the mounting bracket to the pinch weld using (1) M8 flanged hex cap screw, and (1) M8 toothed lock washer, see Figure 6. Do not fully tighten at this time.
 - Take the driver's side step bar and place it on the mounting cradles then attach the step bar using (6) M8 button head cap screws, (6) M8 toothed lock washers, and (6) M8 flat washers, see Figure 7.
 - Align and adjust as needed then tighten all hardware at this time. Torque all M8 hardware to 15-20 ft-lbs.
 - Follow the same steps to install the passenger side mounting brackets and step bar.

To protect your investment, wax this product after installing. Regular waxing is recommended to add a protective layer over the finish. Do not use any type of polish or wax that may contain abrasives that could damage the finish.

For stainless steel: Aluminum polish may be used to polish small scratches and scuffs on the finish. Mild soap may be used also to clean the Sidebar.

For gloss black finishes: Mild soap may be used to clean the Sidebar.

Driver Side Shown

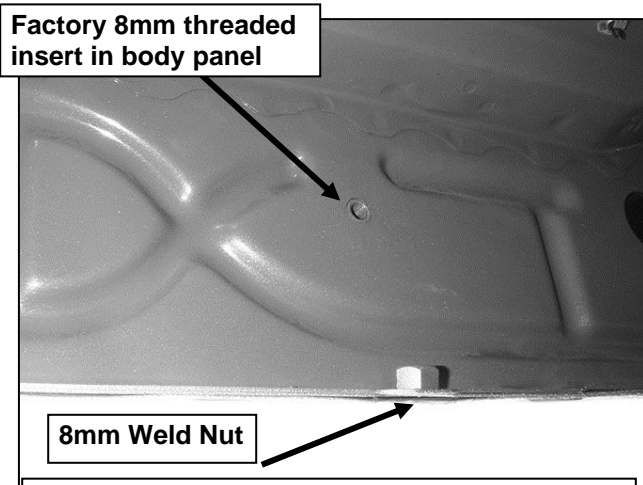

(Fig 1) Example of factory weld nut on mounting tab and threaded hole in body panel

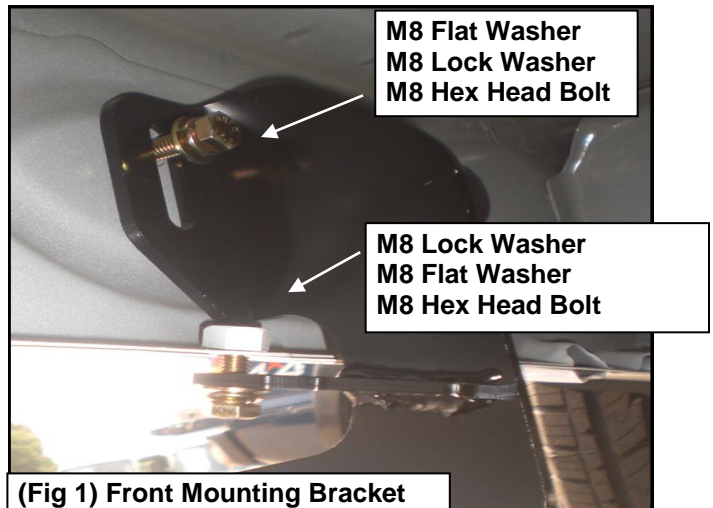

(Fig 1) Front Mounting Bracket and Center Mounting Bracket

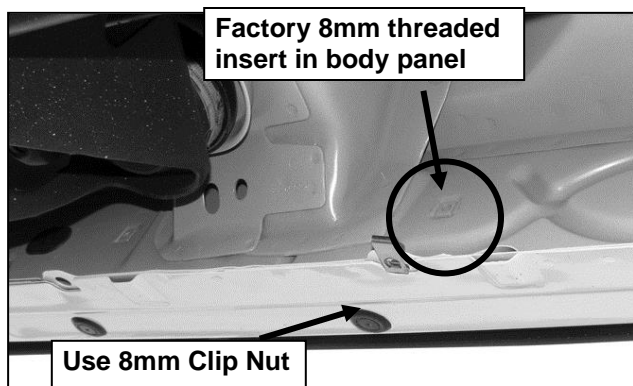

(Fig 3) Example of factory hole in flat mounting tab and threaded hole in body panel

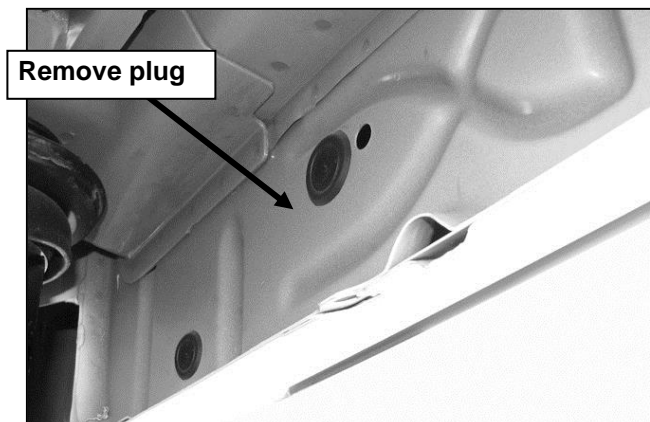

(Fig 4) Example of large hole in inner body panel

4" OVAL BEND STEP BARS ROCKER PANEL MOUNT
2015 1500 SILVERADO/SIERRA DOUBLE CAB / CREW CAB
2015 2500 / 3500 DOUBLE CAB / CREW CAB
EXCLUDES DIESEL

