



INSTALLATION INSTRUCTIONS

00-12 CHEVY SUBURBAN 1/2 TON (Excl. 02-06 Z71)

00-12 CHEVY AVALANCHE

00-12 GMC YUKON XL 1/2 TON (Excl. 02-06 Z71)

3" SIDEBARS

PART NUMBER #1-0992 1-5992

IMPORTANT ALERT: GM uses a very strong thread-locking compound on all body bolts. Use of an air assisted impact ratchet can cause damage to the threads on factory body mount bolts and the internal nut assembly because of this thread locking compound.

We only recommend the use of hand tools to slowly remove and reinstall body mount bolts on all GM vehicles.

PROCEDURE:

CRITICAL INFORMATION: If during the removal process, it becomes increasingly difficult to unscrew the body mount bolt with hand tools, tighten the bolt several rotations to clear the thread locking compound from the threads, then reverse direction and continue to unscrew until the body mount bolt is out. Repeat this process as necessary on all GM body mount bolts. Use of an appropriate anti-seize compound is highly recommended for re-installation. Tighten body mount bolt to factory torque specifications for your particular model year.

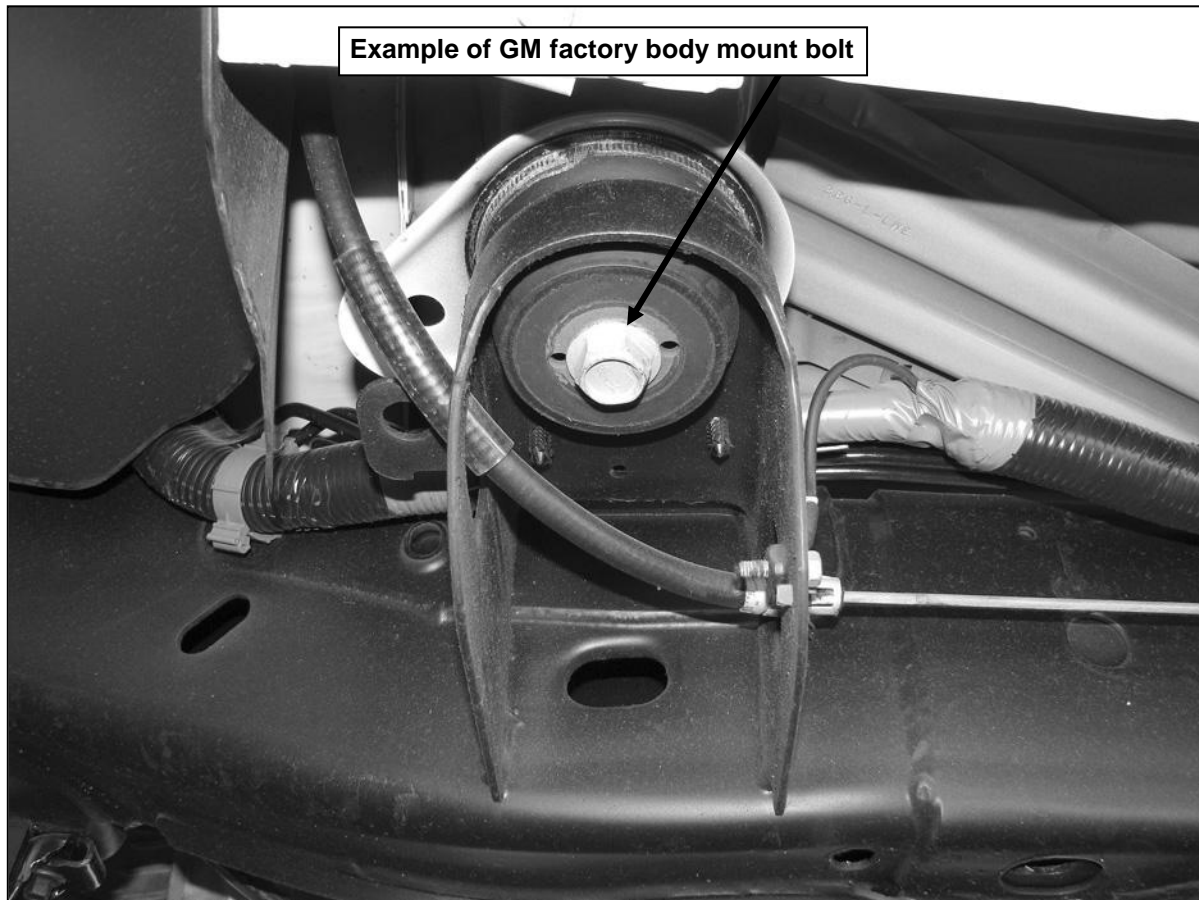

Example of GM factory body mount bolt

Read the instructions completely before you begin the installation. NOTE: Pictures are for reference only, actual brackets may be different. Installation is the same

PARTS LIST

(2) SIDE TUBES WITH STEPS	(4) ½" x 2" HEX HEAD BOLTS
(2) FRONT MOUNT BRACKETS	(10) ½" FLAT WASHERS
(2) REAR MOUNT BRACKETS	(10) ½" LOCK WASHERS
(2) CENTER MOUNT BRACES	(2) 8-1.25mm x 25mm HEX BOLTS
(6) M12-1.75 x 120mm HEX HEAD BOLTS (ONLY FOR 00-06 MODEL)	
(2) 8mm x 24mm x 2mm FLAT WASHERS	
(2) 8mm LOCK WASHERS	

PROCEDURE

1. Begin installation by working on driver side of the vehicle (see Figures 1.1 – 1.4).
2. From underneath truck, loosen and remove body mount bolts that run upward through mounts into floorboard. Attach and secure Front Mount Bracket to underside of vehicles front body mount (see Figure 1.2) with (1) M12 – 1.75 x 120mm bolt (**For 07-on models, use the factory bolt on the vehicle**), (1) ½" split lock washer, and (1) ½" flat washer. Hand Tighten.
3. Attach and secure Rear Mount Bracket to underside of vehicles rear body mount as shown in Figure 1.4, in same manner as the front. Repeat for Center Brace, (see Figure 1.3).
4. Attach Side Tube to Front and Rear Brackets using (1) ½" x 2" bolt, (1) ½" lock washer and (1) ½" flat washer for each bracket and hand tighten. Fasten Center Brace to Side Tube using (1) 8mm x 25mm Hex Bolt, (1) 8mm Lock Washer and (1) 8mm Flat Washer. Adjust Side Tube so that it is level and centered, and tighten all bolts to complete the driver-side assembly.
5. Repeat process for passenger side of vehicle to complete installation.

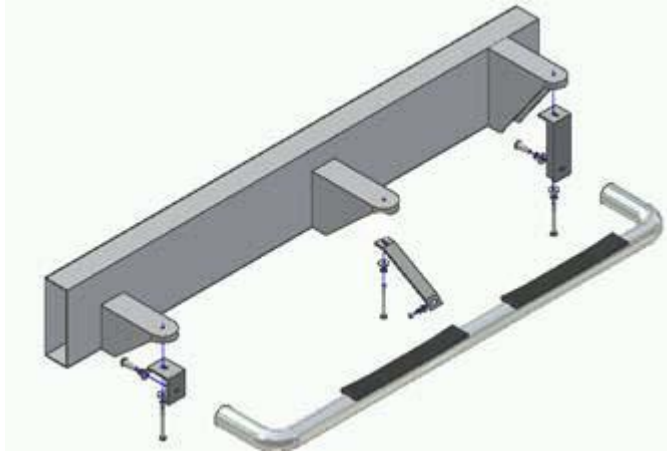

Figure 1.1 – Driver-Side Full Assembly View

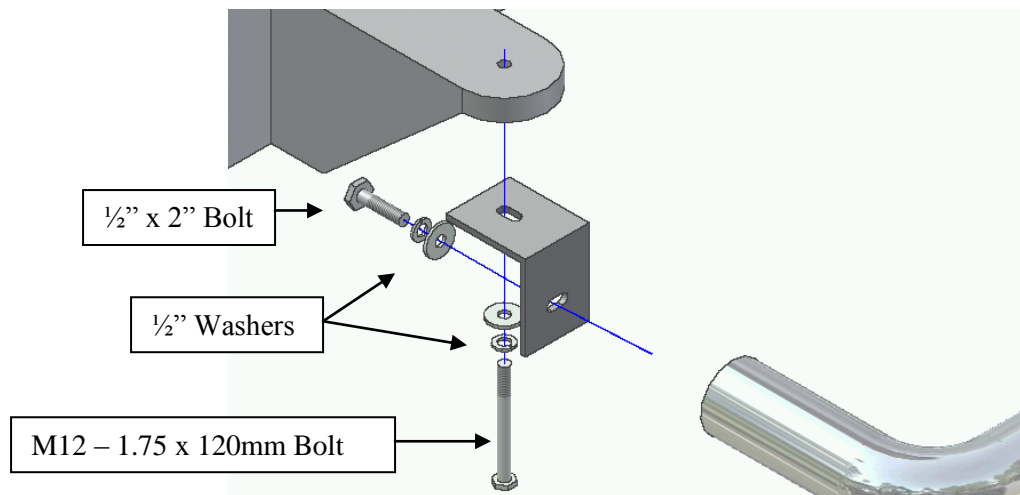

Figure 1.2 – Front Bracket

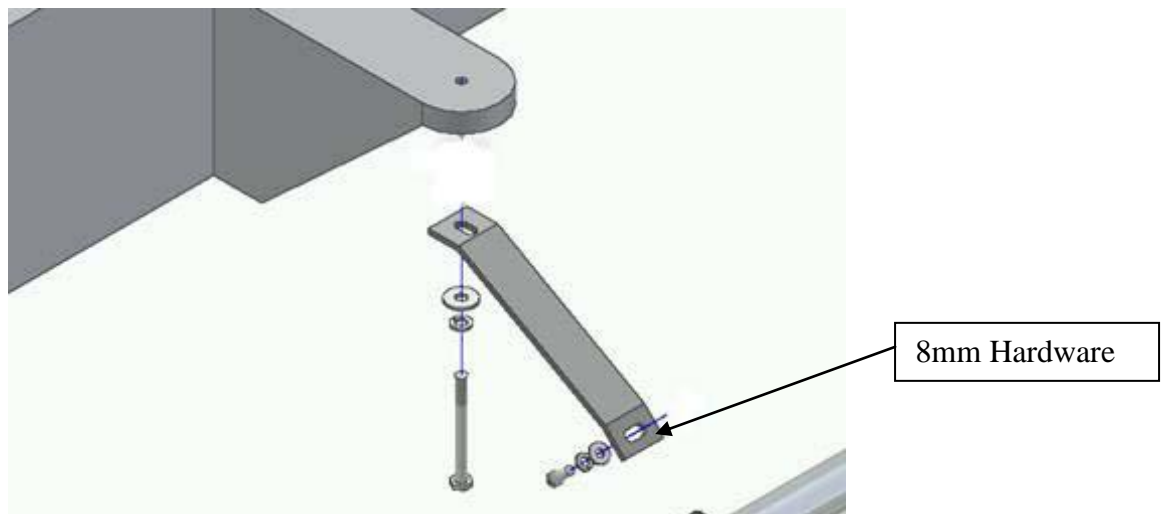

Figure 1.3 – Center Brace

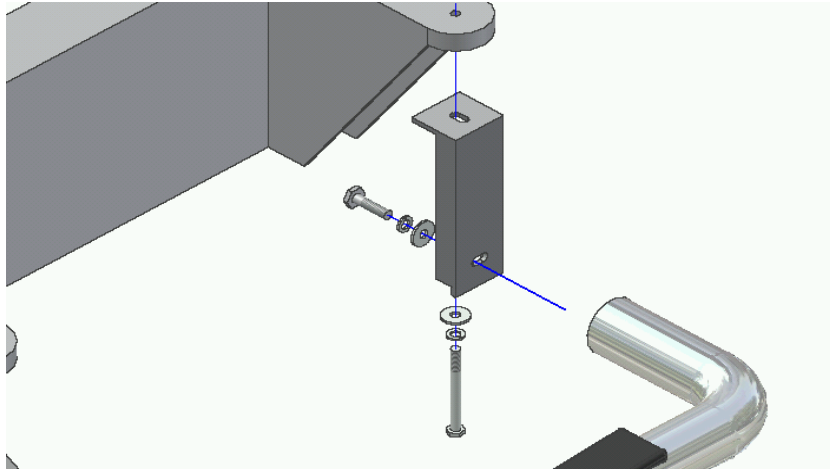

Figure 1.4 – Rear Bracket