



INSTALLATION INSTRUCTIONS

SIDE BAR

08 -13 JEEP LIBERTY
PART NUMBER 1-0823 1-5823

PARTS LIST:

1	Passenger Sidebar	4	10-1.50mm x 25mm Bolt Plates
1	Driver Sidebar	4	10mm Nylock Nuts
1	Passenger/Right Front Mounting Bracket	4	10mm ID x 27mm OD x 3mm Flat Washers
1	Passenger/Right Rear Mounting Bracket	8	8-1.25mm x 25mm Hex Head Bolts
1	Driver/Left Front Mounting Bracket	8	8-1.25mm x 35mm Hex Head Bolts
1	Driver/Left Rear Mounting Bracket	8	8mm Nylock Nuts
6	Fit Adjustment Spacers (127 x 25 x 3mm)	8	8mm Lock Washers
		24	8mm ID x 24mm OD x 2mm Flat Washers

Driver Side Mounting Brackets

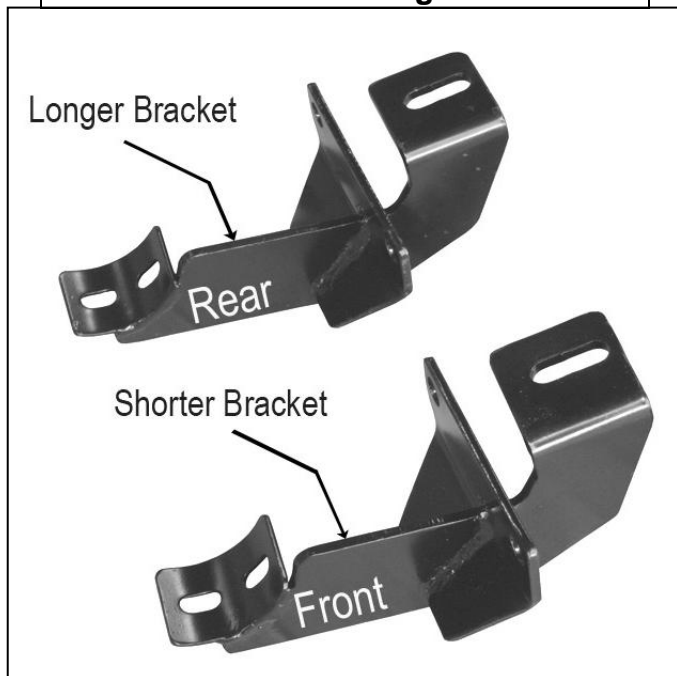

Passenger Side Mounting Brackets

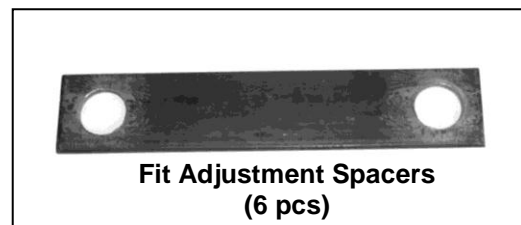
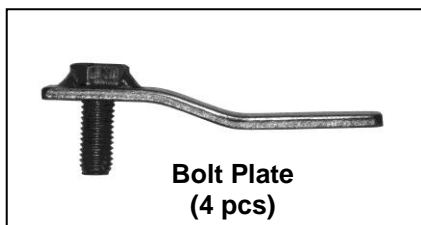
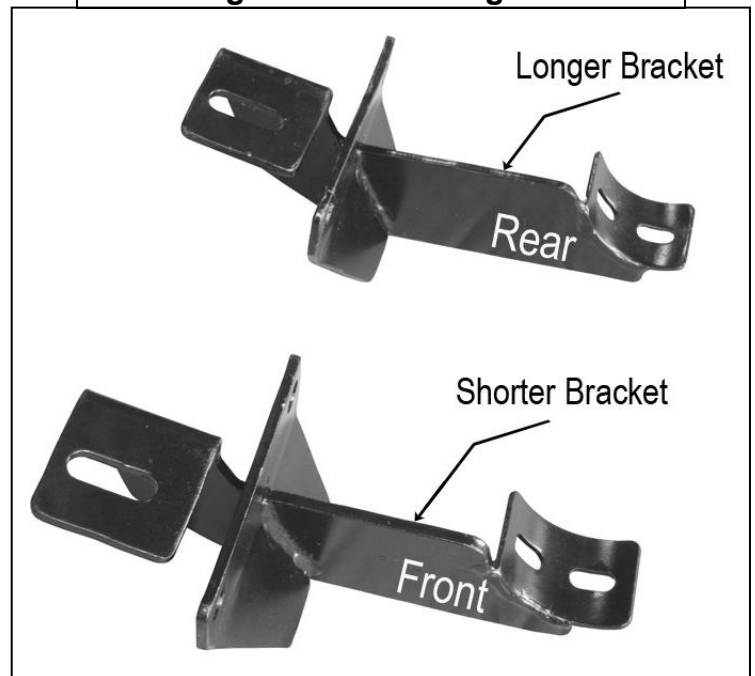

PROCEDURE:

- 1. REMOVE CONTENTS FROM BOX. VERIFY ALL PARTS ARE PRESENT. READ INSTRUCTIONS CAREFULLY BEFORE STARTING INSTALLATION.**
- Starting on the driver side front of the vehicle, insert (1) 10-1.50mm x 25mm Bolt Plate into rectangular hole located in the side panel, so threaded Bolt Plate drops through round hole **(Figure 1)**.
- Partially hang driver side front Mounting Bracket to already inserted Bolt Plate using the included (1) 10mm Nylock Nut and (1) 10mm Flat Washer to secure it **(Figure 2)**.
NOTE: Rear Mounting Brackets are $\frac{1}{4}$ " longer than front Mounting Brackets and the 10mm mounting tab location on the brackets face the front of the vehicle. Make sure that the vertical mounting locations in the Brackets are on the outer side of pinch weld.
- Attach Mounting Bracket to pinch weld using the included (2) 8-1.25mm x 25mm Hex Head Bolts, (2) 8mm Nylock Nuts, and (4) 8mm Flat Washers **(Figure 2)**. Do not tighten at this time.
NOTE: Depending upon the vehicle, the front of the Sidebar might make contact with front factory flares. If so, place one, two, or three of the Fit Adjustment Spacers on the outside of the pinch weld between the Mounting Bracket and the pinch weld as needed **(Figure 4)**.
- Repeat steps 2-4 for driver side rear Mounting Bracket **(Figure 3)**.
- Position driver Sidebar onto Mounting Brackets. Attach Side Bar to Mounting Brackets using the included (4) 8-1.25mm x 25mm Hex Head Bolts, (4) 8mm Lock Washers, and (4) 8mm Flat Washers **(Figure 5)**. Do not tighten at this time.
- Level and adjust Side Bar properly; and then tighten all hardware at this time.
- Repeat steps 2-7 for passenger Sidebar **(Figure 6 & 7)**.
- Do periodic inspections to the installation to make sure that all hardware is secure and tight.

To protect your investment, wax this product after installing. Regular waxing is recommended to add a protective layer over the finish. Do not use any type of polish or wax that may contain abrasives that could damage the finish.

For stainless steel: Aluminum polish may be used to polish small scratches and scuffs on the finish. Mild soap may be used also to clean the Sidebar.

For gloss black finishes: Mild soap may be used to clean the Sidebar.

