

**SAFETY WARNING!**  
Always use the correct tools, and wear safety goggles. We **STRONGLY** recommend installation by a licensed mechanic on a properly secured locking lift.

**TIRE FITMENT ADVICE**  
The best way to ensure proper tire fitment is to install the kit before purchasing your wheels and tires. Always test fit tires and wheels before purchasing.

**VEHICLE RIDE WARNING!**  
Trucks with lift or level kits installed have a higher center of gravity. Aggressive and sudden direction changes may cause a tip over.

### 406035 Chevrolet 1500 Pickup 6-Lug Lift Kit

- This kit contains:
- 2- Lower Strut Spacers
  - 6- Upper Strut Spacers
  - 1- Hardware Pack
  - 2- Rear Lift Blocks
  - 4- U-bolts
  - 1- U-bolt Hardware Pack
- Instructions, Warranty card, Stickers



### Installation Tips

**Always use caution handling ABS or wheel sensor wiring. Avoid tension of any kind on wiring harness as this may cause damage or failure.**

1. Trucks are often not level side to side from the factory. Please measure before installation.
2. Re-torque all hardware to manufactures specifications
3. When aligning, to get the best tire wear use our supplied specifications. OEM specifications are for trucks with stock wheels and tires. Larger tires will wear differently.
4. All instructions are written with vehicle on a 2-post lift with tires removed.

This kit includes six (6) upper strut spacer (3 each side) that are used for adjusting the front ride height. Each plate will lift the front approx. 1/2". To achieve maximum lift use 3 plates per side.

### Step 1

Loosen and remove the upper ball joint nut, tie rod nut, and Sway bar nut. A hammer may be needed to break the ball joint and tie rod free.

### Special Note:

On 4X4 models you must remove the drive axle nut. **Failure to follow this step may cause damage to axle CV joint.**

### Step 2

Remove the strut from the vehicle, install the three supplied spacers on top of the strut. Reinstall the strut, using the **new** nuts provided. Do not use the OEM nuts with this kit!

### Step 3

Install the lower U-shaped spacer supplied with the kit as shown in Figure "A". Use the hardware provided. The OEM bolts will not work.

**A pry bar will be needed. The axle nut should be removed or the axle will hyperextend and cause damage.**



### Figure A

Illustration is for reference only. Part dimensions will vary from kit to kit.

**TIRE FITMENT ADVICE**  
The best way to ensure proper tire fitment is to install the kit before purchasing your wheels and tires. Always test fit tires and wheels before purchasing.

**VEHICLE RIDE WARNING!**  
Trucks with lift or level kits installed have a higher center of gravity. Aggressive and sudden direction changes may cause a tip over.

## 406035 Installation Instructions continued

### Step 4

Install lower strut mount with bolts that are included in the kit. The OEM bolts will not work. Using the pry bar, reinstall the upper ball joint and nut. Reinstall the axle nut. Install the remaining upper strut mount nuts and reinstall the sway bar link.

## Rear Installation

Disconnect ABS wires so they can droop. Loosen lower shock bolt and remove. Use pit jack to support the differential. Remove U-bolts from one side of the truck only. This will help keep the differential steady. Remove factory block and install TRUXXX lift block between differential and leaf spring as shown in illustration below. Install U-bolts supplied with TRUXXX kit. Re-install lower shock bolts. Repeat on the other side of the truck.

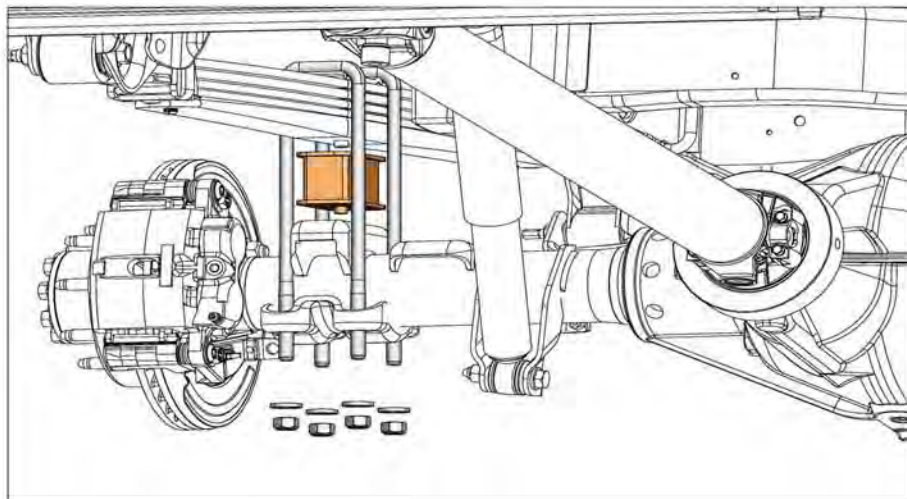

**Alignment notes:**

We recommend that a technician with experience doing alignments on lifted trucks perform the alignment. Large tires wear differently than OEM sized tires. Always do an alignment after changing tires on a vehicle.

	Left	Right
Caster (degrees)	2	2.5
Camber (degrees)	0	-.250
Toe	1/16 or .0625 inch toe in	
Special Tools	none	