

Toll free: 888-660-5892
email: info@truxxx.com

TIRE FITMENT ADVICE
The best way to ensure proper tire fitment is to install the kit before purchasing your wheels and tires. Always test fit tires and wheels before purchasing.

VEHICLE RIDE WARNING!
Trucks with lift or level kits installed have a higher center of gravity. Aggressive and sudden direction changes may cause a tip over.

406012 Cheverlot Avalanche, Tahoe, Suburban, GMC Yukon, Yukon XL & Denali 4x2/4x4 6-Lug Lift and Level Kit

- This kit contains:
- 2- Lower Strut Spacers
 - 6- Upper Strut Spacers
 - 1- Hardware Pack
 - 2- Rear Spring Spacers
 - Instructions, Warranty card
 - Stickers



Installation Tips

Always use caution handling ABS or wheel sensor wiring. Avoid tension of any kind on wiring harness as this may cause damage or failure.

1. Trucks are often not level side to side from the factory. Please measure before installation.
2. Re-torque all hardware to manufactures specifications
3. When aligning, to get the best tire wear use our supplied specifications. OEM specifications are for trucks with stock wheels and tires. Larger tires will wear differently.
4. All instructions are written with vehicle on a 2-post lift with tires removed.

This kit includes six (6) upper strut spacer (3 each side) that are used for adjusting the front ride height. Each plate will lift the front approx. 1/2". To achieve maximum lift use 3 plates per side.

Step 1

Loosen and remove the upper ball joint nut, tie rod nut, and Sway bar nut. A hammer may be needed to break the ball joint and tie rod free.

Special Note:

On 4X4 models you must remove the drive axle nut. **Failure to follow this step may cause damage to axle CV joint.**

Step 2

Remove the strut from the vehicle, install the three supplied spacers on top of the strut. Reinstall the strut, using the new nuts provided. Do not use the OEM nuts with this kit!

Step 3

Install the lower U-shaped spacer supplied with the kit as shown in Figure "A". Use the hardware provided. The OEM bolts will not work.

A pry bar will be needed. The axle nut should be removed or the axle will hyperextend and cause damage.



Figure A

Illustration is for reference only. Part dimensions will vary from kit to kit.

Installation Instructions continued on reverse

Toll free: 888-660-5892
email: info@truxxx.com

TIRE FITMENT ADVICE
The best way to ensure proper tire fitment is to install the kit before purchasing your wheels and tires. Always test fit tires and wheels before purchasing.

VEHICLE RIDE WARNING!
Trucks with lift or level kits installed have a higher center of gravity. Aggressive and sudden direction changes may cause a tip over.

406012 Installation Instructions continued

Step 4

Install lower strut mount with bolts that are included in the kit. The OEM bolts will not work. Using the pry bar, reinstall the upper ball joint and nut. Reinstall the axle nut. Install the remaining upper strut mount nuts and reinstall the sway bar link.

Rear Installation

Support differential with jack. Starting on one side disconnect ABS wires so they can droop. Disconnect sway bar and remove lower shock bolt. Lower jack and remove spring. Position TRUXXX spacer over insulator on top of spring as shown (see illustration). Reinstall spring and reconnect all components. Repeat installation on other side.

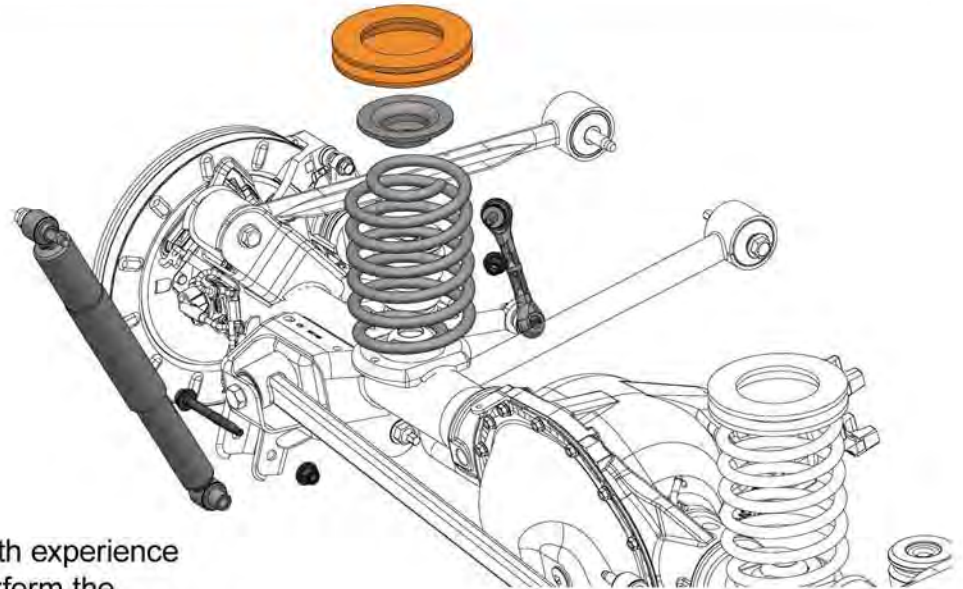

Alignment notes:

We recommend that a technician with experience doing alignments on lifted trucks perform the alignment. Large tires wear differently than OEM sized tires. Always do an alignment after changing tires on a vehicle.

	Left	Right
Caster (degrees)	2	2.5
Camber (degrees)	0	-.250
Toe	1/16 or .0625 inch toe in	
Special Tools	none	