

Toll free: 888-660-5892
email: info@truxxx.com

TIRE FITMENT ADVICE
The best way to ensure proper tire fitment is to install the kit before purchasing your wheels and tires. Always test fit tires and wheels before purchasing.

VEHICLE RIDE WARNING!
Trucks with lift or level kits installed have a higher center of gravity. Aggressive and sudden direction changes may cause a tip over.

404035 Chevrolet/GM 6-Lug Level Kit

This kit contains:

- 2 - Torsion Keys
- 2 - Shock Brackets
- 1 - Hardware Pack
- 2 - Rear Lift Blocks
- 4 - U-Bolts
- 1 - U-Bolt Hardware Pack
- Instructions
- Warranty Card
- Stickers



Installation Tips

Always use caution handling ABS or wheel sensor wiring. Avoid tension of any kind on wiring harness as this may cause damage or failure.

1. Trucks are often not level side to side from the factory. Please measure before installation.
2. Re-torque all hardware to manufactures specifications
3. When aligning, to get the best tire wear use our supplied specifications. OEM specifications are for trucks with stock wheels and tires. Larger tires will wear differently.
4. All instructions are written with vehicle on a 2-post lift with tires removed.

Front Installation

Step 1

Remove torsion key adjusting bolt. Using a torsion bar release tool (or similar c-clamp type ball joint press), apply pressure to the torsion key so the keeper nut in the cross member can be removed. Release pressure from torsion key and slide torsion bar forward allowing key to be removed.

Step 2

Remove lower shock mount bolt and, Install supplied shock mount bracket and reattach shock.

Step 3

Install TRUXXX torsion key. Using torsion bar tool, apply pressure to torsion key and install keeper and adjusting bolt. **IMPORTANT: the torsion bar must extend completely through key at least 1/4".**

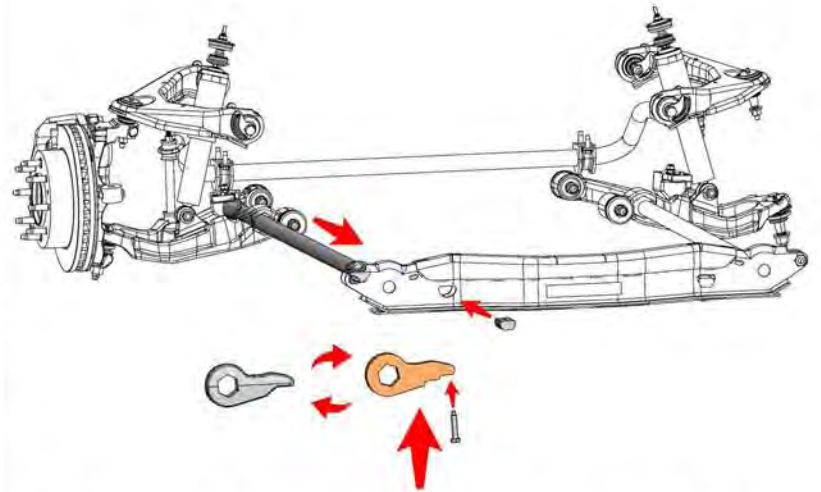

Figure A: Illustration is for reference only. Part dimensions will vary from kit to kit.

Installation Instructions continued on reverse

Toll free: 888-660-5892
email: info@truxxx.com

TIRE FITMENT ADVICE
The best way to ensure proper tire fitment is to install the kit before purchasing your wheels and tires. Always test fit tires and wheels before purchasing.

VEHICLE RIDE WARNING!
Trucks with lift or level kits installed have a higher center of gravity. Aggressive and sudden direction changes may cause a tip over.

404035 Installation Instructions Continued

Rear Installation

Disconnect any ABS wires so they can droop. Loosen lower shock bolt and remove. Use a pit jack to support the differential. Remove U-bolts from one side of the truck only. This will help keep the differential steady. Remove factory block and Install TRUXXX lift block between differential and leaf spring as shown in illustration below.. Install U-bolts supplied with TRUXXX kit. Re-install lower shock bolts. Repeat on the other side of the truck.

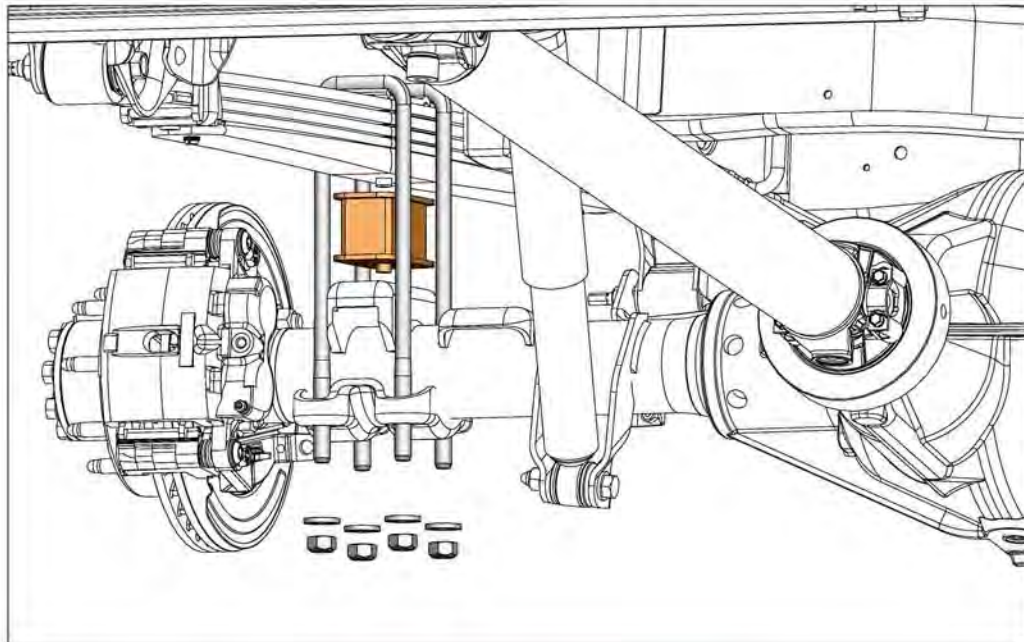

Torque U-bolt hardware to 75 ft. lbs.
Never reuse U-bolts

| | Left | Right |
|------------------|----------------------------|--------------|
| Caster (degrees) | 2 | 2.5 |
| Camber (degrees) | 0 | -1/4 or -.25 |
| Toe | 1/32 or .03125 inch toe in | |
| Special Tools | none | |

Alignment notes:
We recommend that a technician with experience doing alignments on lifted trucks perform the alignment. Large tires wear differently than OEM sized tires. Always do an alignment after changing tires on a vehicle.