

Toll free: 888-660-5892  
email: info@truxxx.com

**TIRE FITMENT ADVICE**  
The best way to ensure proper tire fitment is to install the kit before purchasing your wheels and tires. Always test fit tires and wheels before purchasing.

**VEHICLE RIDE WARNING!**  
Trucks with lift or level kits installed have a higher center of gravity. Aggressive and sudden direction changes may cause a tip over.

### 402010 Trailblazer Lift and Level Kit

This kit contains:

- 2- Front Spring Preload Spacers
- 2- Front Top Shim Spacers
- 2- Rear Spring Spacers

Instructions  
Warranty Card  
Stickers



### Installation Tips

**Always use caution handling ABS or wheel sensor wiring. Avoid tension of any kind on wiring harness as this may cause damage or failure.**

1. Trucks are often not level side to side from the factory. Please measure before installation.
2. Re-torque all hardware to manufactures specifications
3. When aligning, to get the best tire wear use our supplied specifications. OEM specifications are for trucks with stock wheels and tires. Larger tires will wear differently.
4. All instructions are written with vehicle on a 2-post lift with tires removed.

### Step 1

Loosen and remove the upper ball joint nut, tie rod nut, and sway bar nut. A hammer may be needed to break the ball joint and tie rod free.

### Special Note:

On 4X4 models you must remove the drive axle nut. **Failure to follow this step will make removal of the strut difficult.**

### Step 2

Remove the strut from the vehicle and **mark the strut for proper re-assembly.** Using a spring compressor tool, disassemble the strut and install the TRUXXX spacer.

\*Refer to Figure A for proper placement.

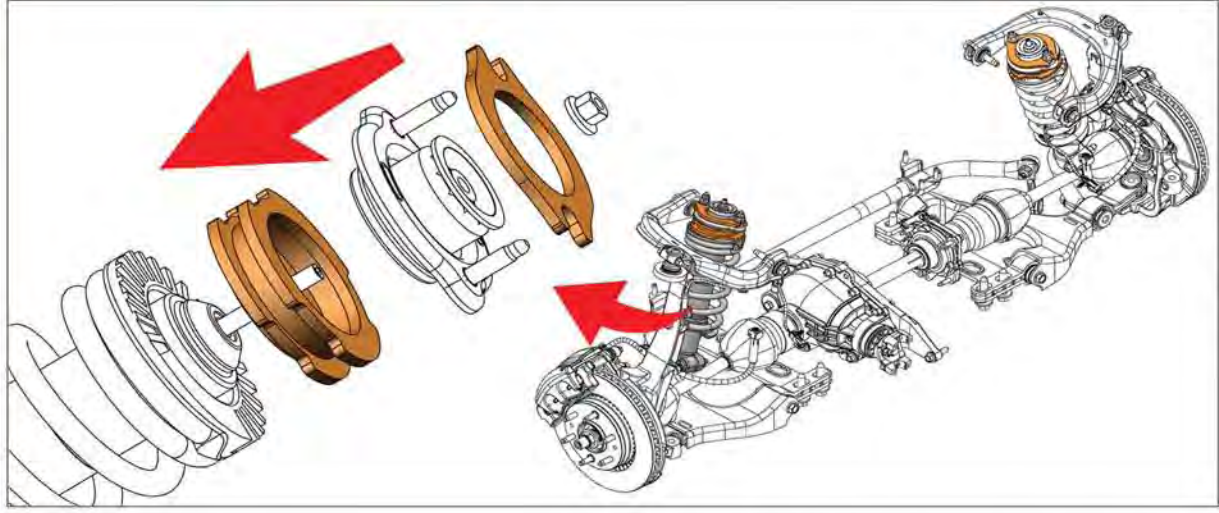

### Figure A

Illustration is for reference only. Part dimensions will vary from kit to kit.

Toll free: 888-660-5892  
email: info@truxxx.com

**TIRE FITMENT ADVICE**  
The best way to ensure proper tire fitment is to install the kit before purchasing your wheels and tires. Always test fit tires and wheels before purchasing.

**VEHICLE RIDE WARNING!**  
Trucks with lift or level kits installed have a higher center of gravity. Aggressive and sudden direction changes may cause a tip over.

## 402010 Installation Instructions continued

### Rear Installation

Support the weight of the rear axle and remove one rear shock. Be careful of the brake hoses they will be at maximum extension while installing this piece. With the shock removed the spring should come out easily. Install the TRUXXX spring spacer into the vehicle as shown in Figure B using the supplied 10mm bolt. Fit the cone shaped bump stop onto the spacer and have an assistant use a pry bar to lever the spring back into place. Reinstall the shock and repeat on the other side.

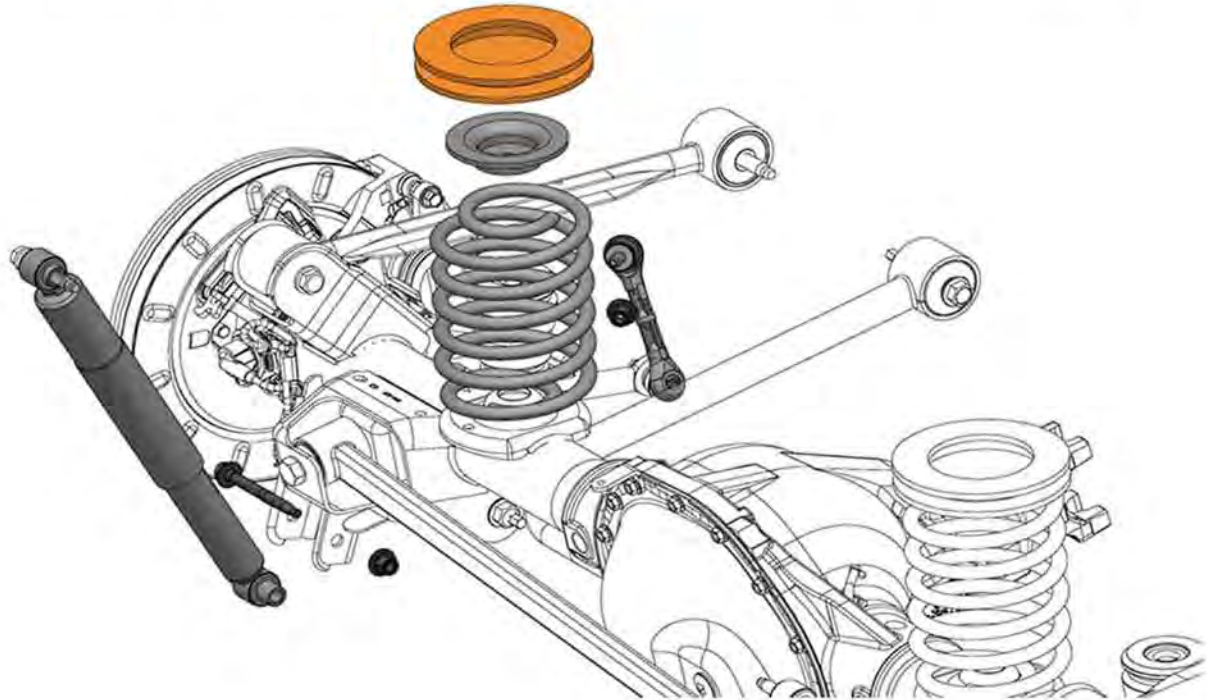

#### Alignment notes:

We recommend that a technician with experience doing alignments on lifted trucks perform the alignment. Large tires wear differently than OEM sized tires. Always do an alignment after changing tires on a vehicle.

| Alignment Specs  | Left                   | Right |
|------------------|------------------------|-------|
| Caster (degrees) | 2                      | 2.5   |
| Camber (degrees) | -.50                   | -.50  |
| Toe (inches)     | 1/16 or .0625 toe in   |       |
| Other Notes      | Rear is not adjustable |       |