

MANUAL

Pro X15



SOFT ROLL-UP TRUCK BED COVER

P/N 1118188 REV C

SAFETY INSTRUCTIONS

1. Do not place objects on or against cover or framework.
2. Do not tie cargo to truck bed cover framework.
3. **Never** allow children or pets to occupy pickup box while cover is closed.
4. Cover is not airtight. Special care is required to keep cargo clean and dry.
5. Fabric cover won't prevent theft of contents inside truck box.
6. Cover must be rolled fully open and secured with retainer straps when towing vehicle backwards.
7. **DO NOT** stow rolled cover against cab window.
8. Cover must be rolled fully open and secured with retainer straps if any part of the truck bed cover is worn or damaged.

OWNER/USER RESPONSIBILITIES

It is the responsibility of the owner/user to read this manual and comply with the operating procedures. The owner/user is also responsible for inspecting the TruXedo cover, and for having parts repaired or replaced when worn or damaged.

Failure to follow safety instructions and warning labels could result in failure of your cover system and/or personal injury.

MESSAGES TO INSTALLER

- Always wear safety glasses and/or other necessary protective equipment when installing your TruXedo truck bed cover.
- These instructions are complete for most pickup models. Additional instructions are included, if required for your truck. Please read entire manual before installing your TruXedo truck bed cover.

COVER MAINTENANCE

- Polyester/Vinyl cover can be hand washed with mild soap and water or cleaned in a car wash. Thoroughly rinse cover to remove any soap residue. For more maintenance info see page 7.

- It is recommended that you periodically check your Pro X15 cover to make sure it is securely attached to your truck bed. Inspect the clamps and front mounting bolts to ensure they were properly installed and have not come loose or knocked out of adjustment during operation. Covers that are used with high frequency or that are subject to vibrations and impact from rough roadways can require adjustment.

Components:

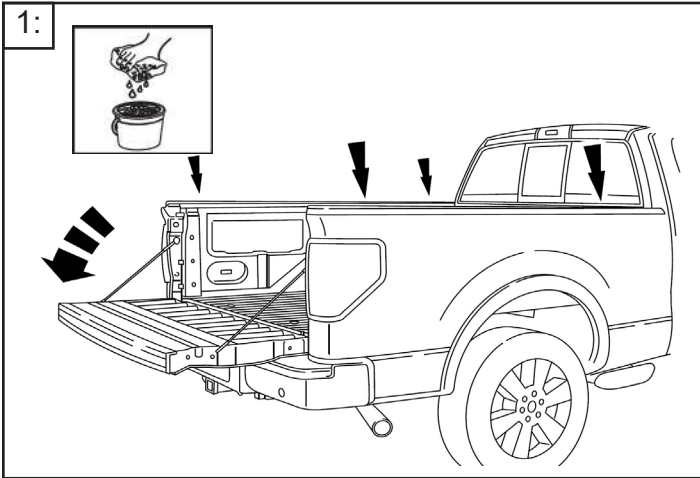
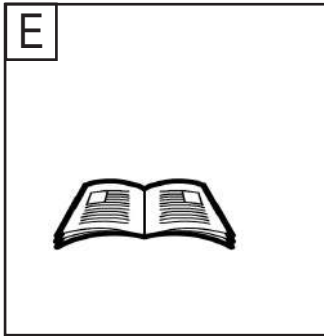
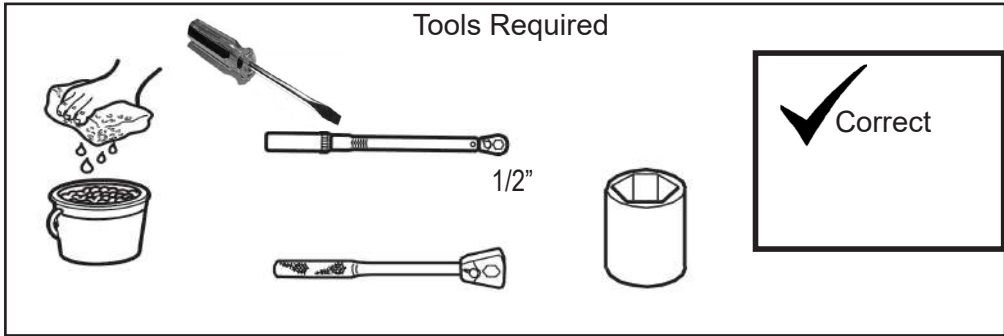
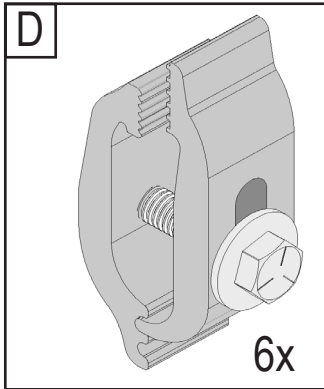
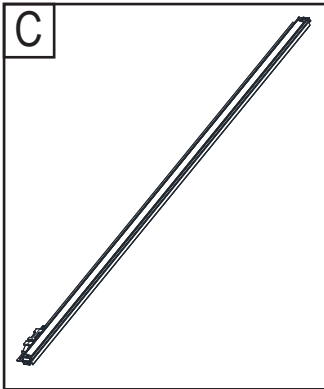
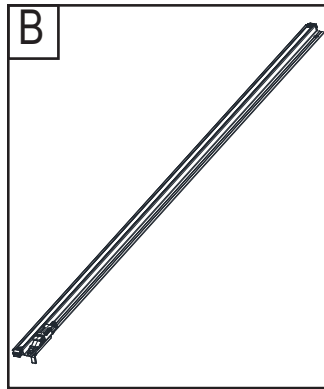
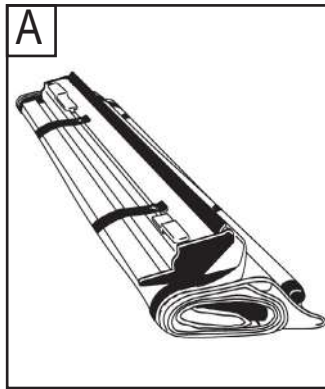

2: If your pickup has factory bed caps you will need to install the bulkhead seal supplied in the shipping box.

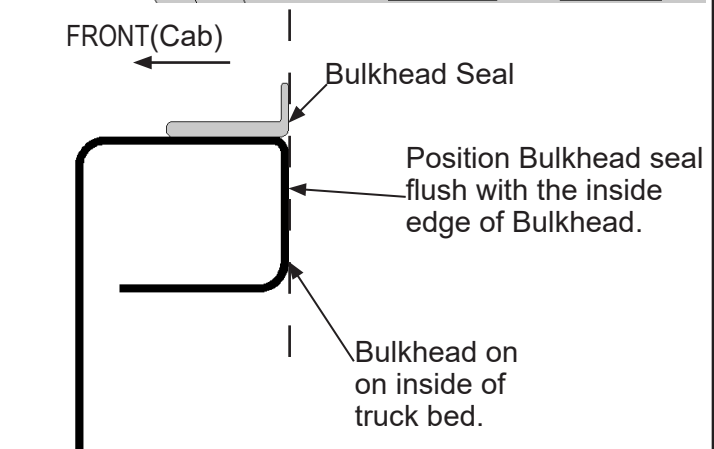
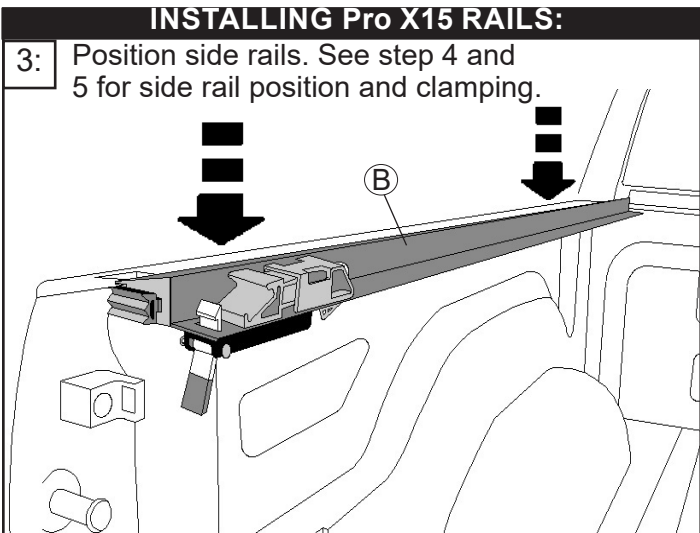
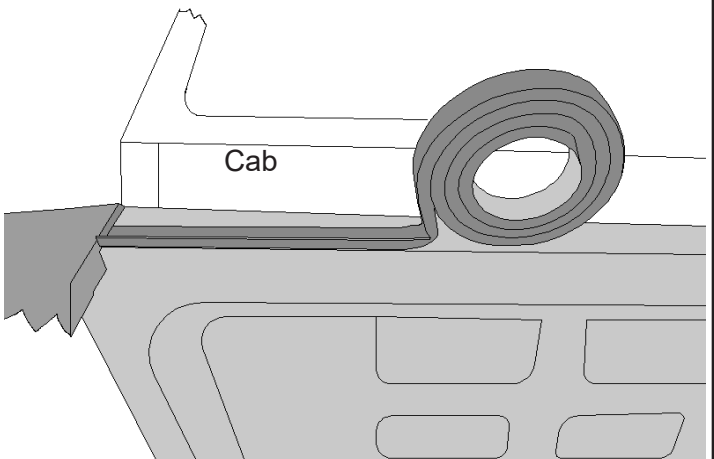

INSTALLING Pro X15 RAILS CONT:

4: It is recommended to close tailgate when positioning the rails.

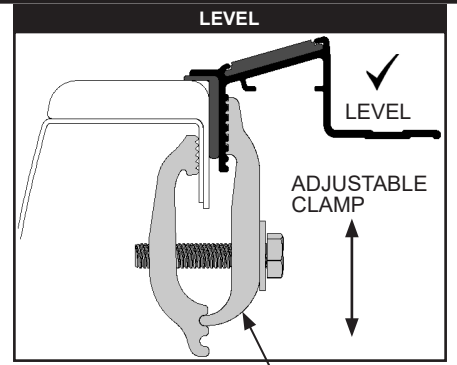
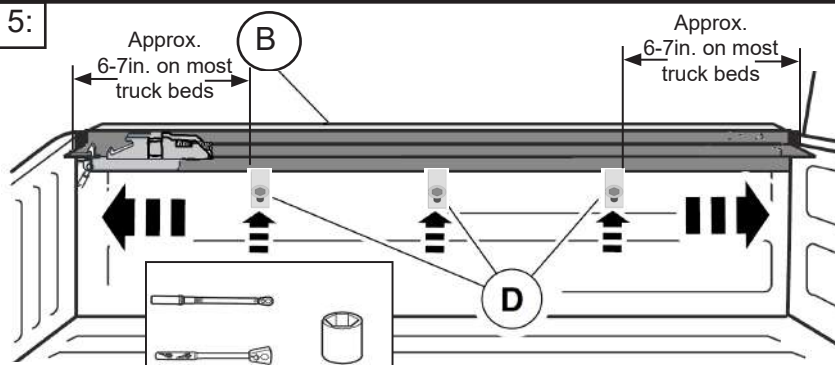
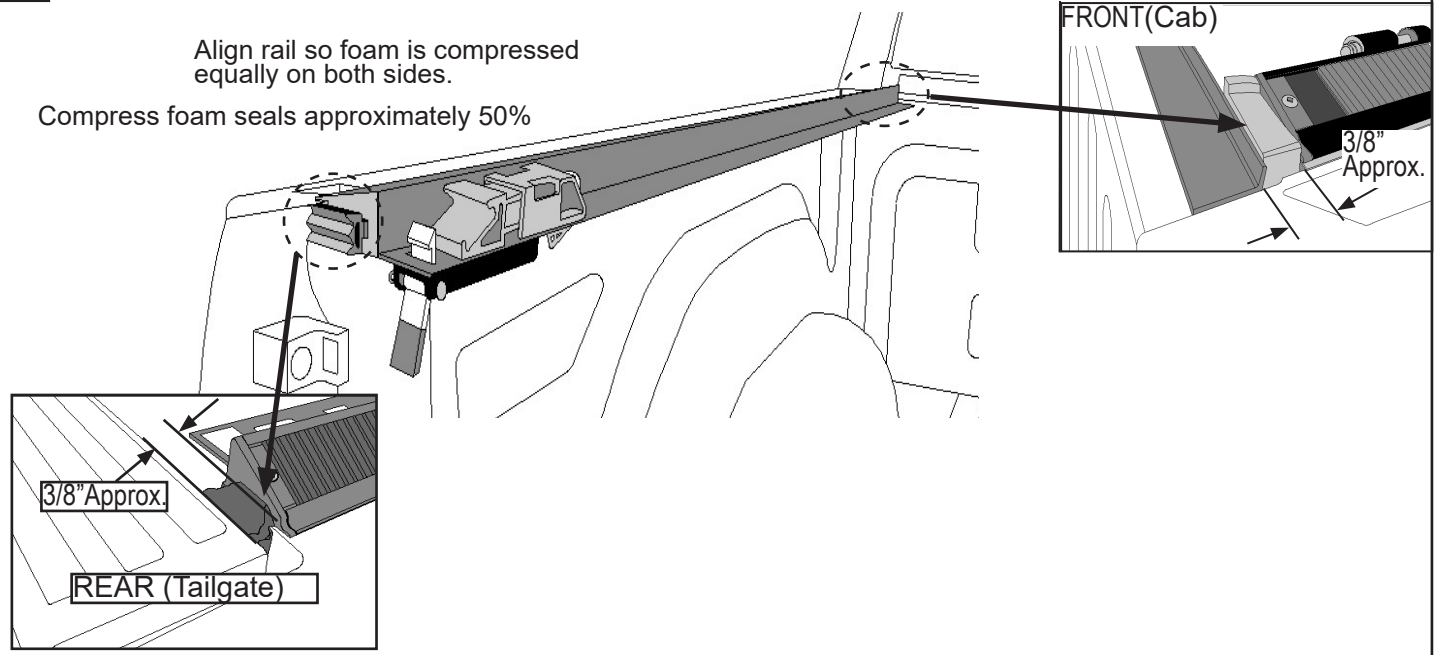

Adjust this part of the clamp upward or downward to achieve a level rail.

ATTENTION: LIP OF X15 RAIL SITS ON TOP OF TRUCK BED RAIL.

Truck Bed Rail.

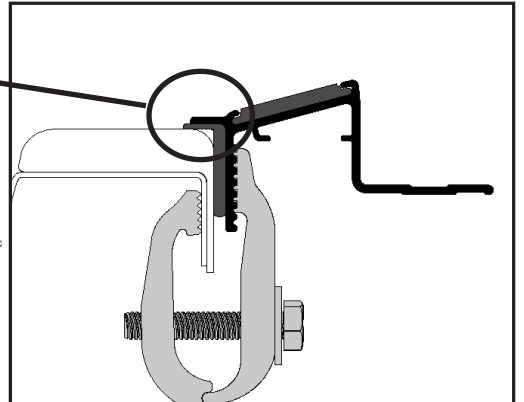
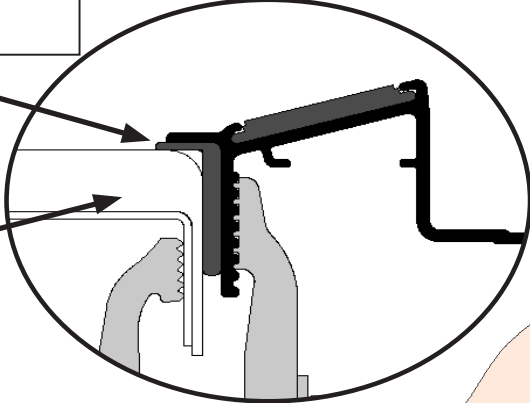

For best results, firmly apply downward pressure on rail while tightening clamps.

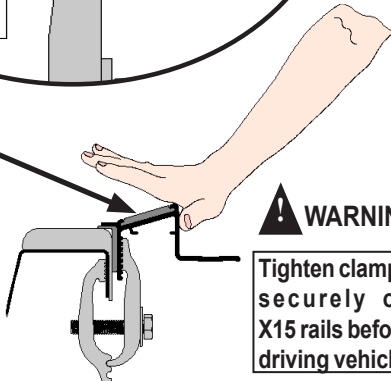

! WARNING
Tighten clamps securely on X15 rails before driving vehicle.

6: Repeat steps 3-5 on passenger side for item C. Proceed to step 7 when complete.

INSTALLING COVER ASSEMBLY:

7: Position cover roll to the front near the cab. Rotate header and screw head into oblong hole as shown.

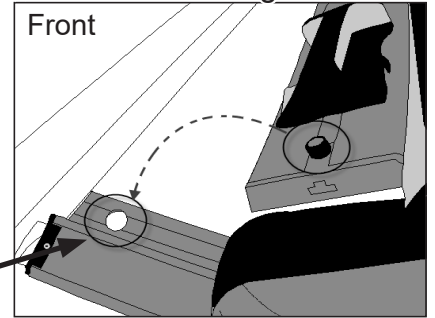
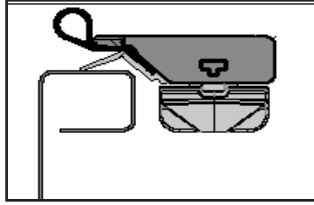
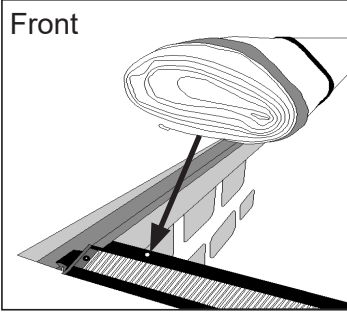

Note: The Pro X15 rail may need to be tilted upward slightly to allow the screw head to drop into oblong hole.

LOCKING COVER ASSEMBLY TO RAILS:

8: Slide header guides into lock position.

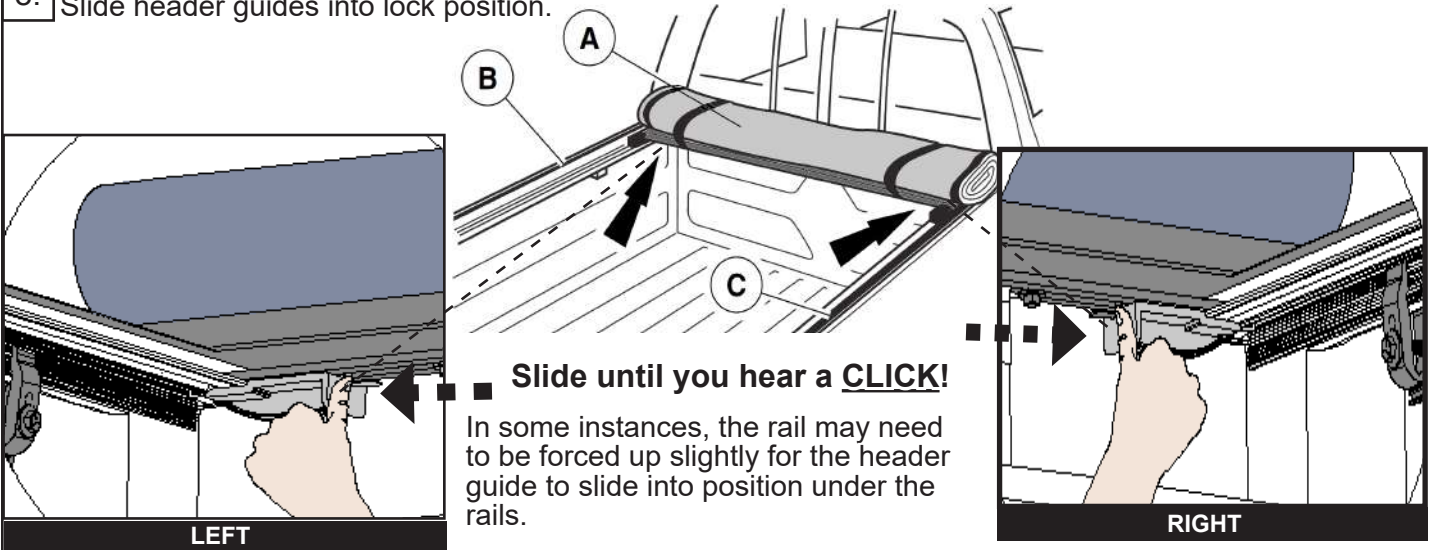

After front header is locked into place, rotate the header stabilizer screws clockwise until the front header is secured with no back and forth movement.



CLOSING THE COVER:

9: Unhook and roll cover to the tailgate.

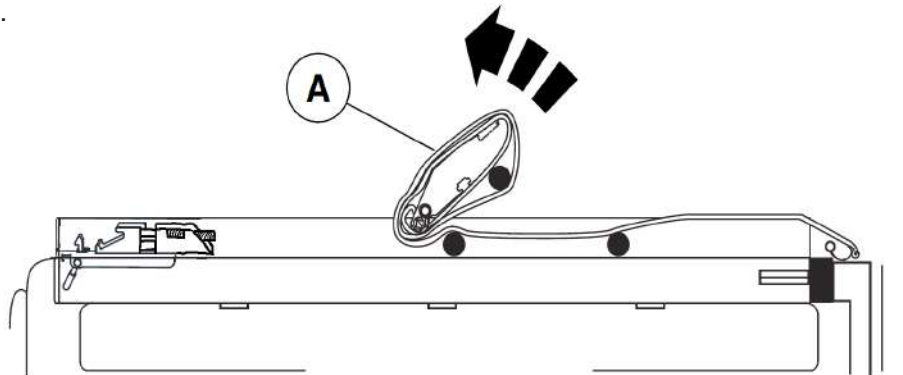
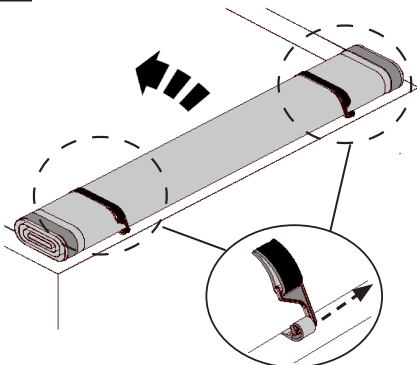

CLOSING THE COVER CONT:

10: Close tailgate, then cover

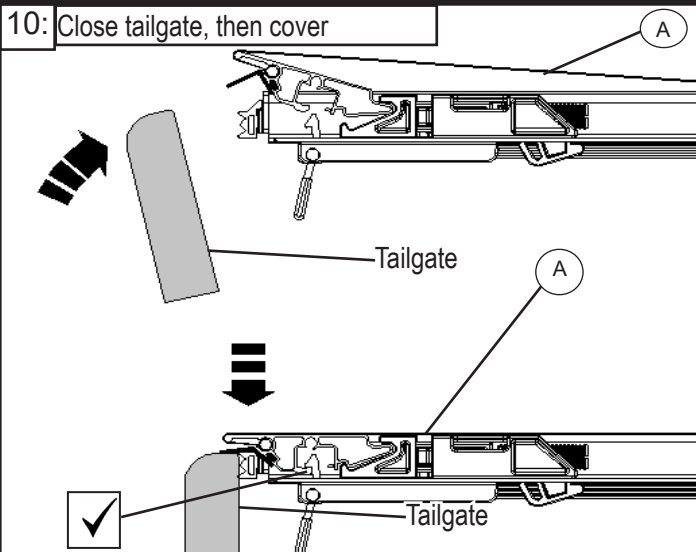

11:

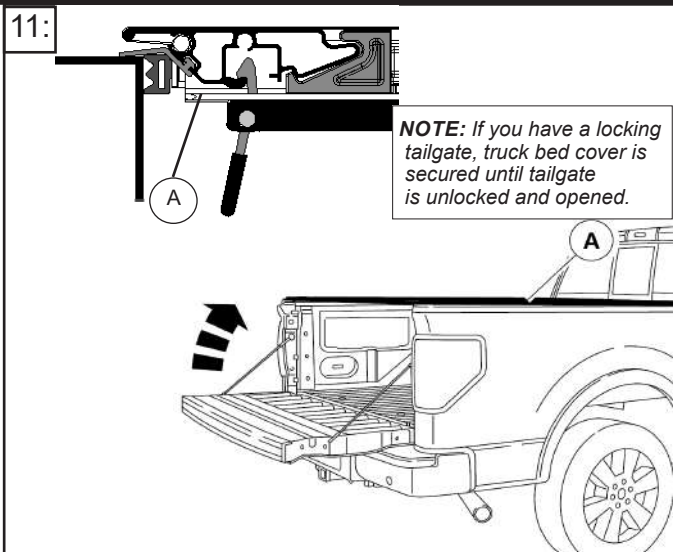

12:

SETTING HOOK AND LOOP FASTENER:

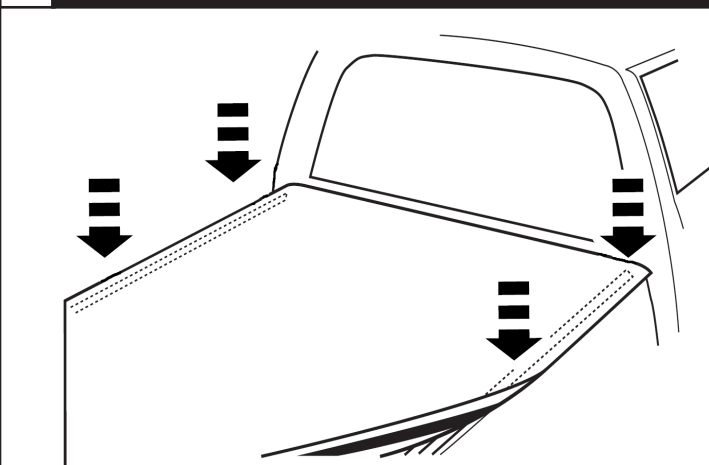

Note: Small wrinkles may be present after closing cover for first time. Remove wrinkles by pulling cover material from each side. For best results have cover unlatched. Relatch rear header after adjustments have been made.

IMPORTANT:
Before driving vehicle, secure hook and loop fastener by running your hand down entire length of each X15 rail. This will prevent wind lifting the cover and causing damage.

OPENING THE COVER:

13:

1. Open tailgate
2. Pull latch on driver side to unlatch cover.
3. Roll Cover to front and secure with retainer straps.

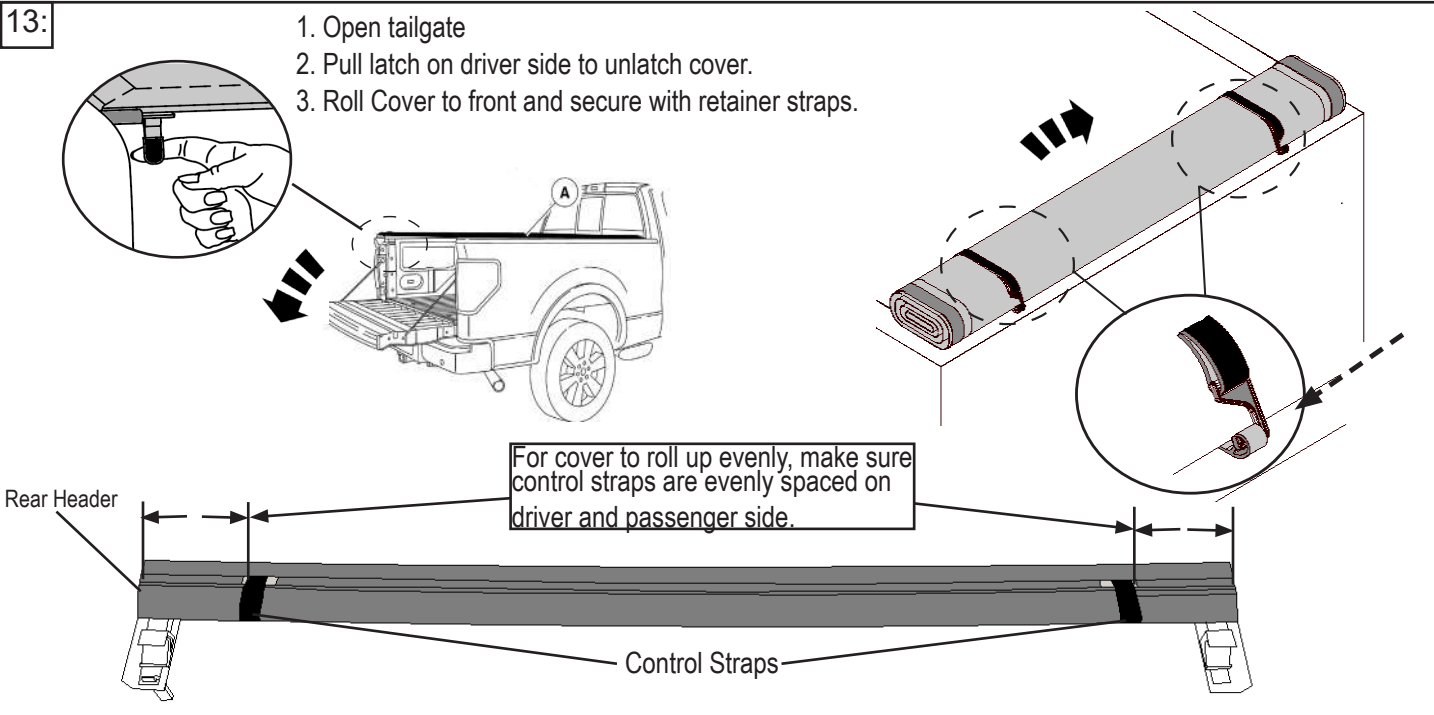

14:

CAUTION

ROLL COVER TIGHT AND SECURE BOTH RETAINER STRAPS. **DO NOT** STOW COVER AGAINST CAB WINDOW.

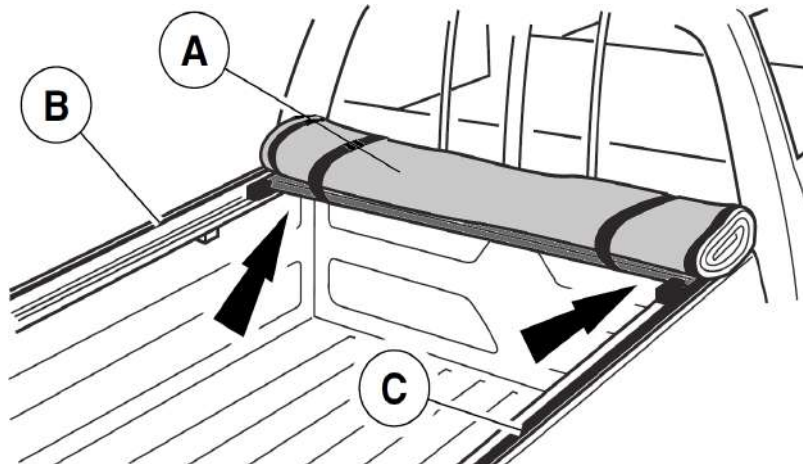

CAUTION

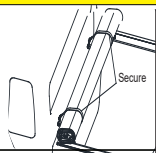

Before driving with cover open, BOTH STRAPS MUST BE SECURED TO RETAINING LOOPS. Failure to do so could cause accidental release of the cover, resulting in personal injury or property damage.

COVER TENSION ADJUSTMENT

15:

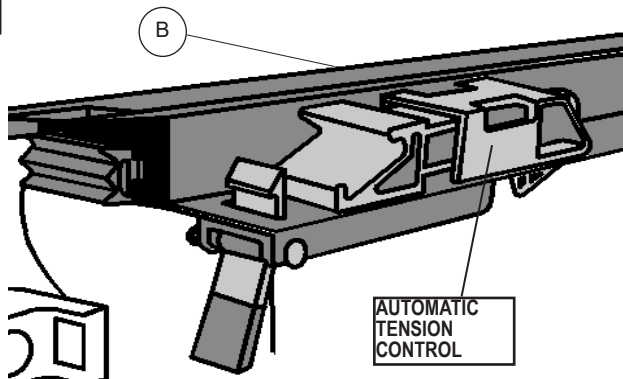

- Spring plunger compensates for material expansion & contraction caused by temperature changes.
- Check cover tension after installation, seasonally, and after extreme temperature changes.
- For best performance, adjust tension regularly to protect your cover against wind wear.

Set tension during warmest/sunniest part of day.

- 1 With the cover closed, release hook and loop fastener from both side rails near cab.
- 2 Check compression of both spring plungers in both rear header stops. Roll cover open and make adjustments.
- 3 If cover is still too loose then re-adjust. Repeat until satisfactory tension has been achieved.

Approx: 1/8in Plunger showing



TROUBLESHOOTING FABRIC/ FABRIC CARE

1. Fabric top surface has wrinkles after rolling cover closed.

- Pull fabric taut from each side. For best results, the help of a second person pulling on the opposite side is preferable.

2. Fabric top surface sags between cross tubes.

- Adjustment to automatic tension control may be required, refer to Step 15.

3. Wind lifts up edge of fabric.

- Make sure to engage hook and loop on driver and passenger side after closing the cover. This may need to be done periodically when taking long trips.

4. Excessive fabric flutter while driving.

- Check fabric tension, refer to Step 15.
- Make sure hook and loop fasteners are set, see step 12.

5. Snow and Ice accumulation on top surface.

- Use broom or brush to remove loose snow and ice. **Do not** use sharp or pointed tools to remove snow and ice .
- Direct sunlight will help melt snow and ice from top surface.

6. How to Clean Fabric.

- Soap, water, and soft fine bristle brush.

TROUBLESHOOTING

HEADER WILL NOT LATCH:

Check Pro X15 rails to make sure they are level. See Step 5.

Make sure the rear header seal is not caught between side rail & rear header.

Check position of side rails on truck bed, they may be positioned incorrectly. See Step 4.

Make sure cover has proper tension. See Step 15.

THE COVER IS TOO TIGHT OR TOO LOOSE:

See Step 12 and 15.

SIDE RAILS TIP DOWNWARD OR UPWARD:

- Reposition clamp up or down, refer to step 5.
- In some cases, a small shim can be used to tip rails upward. Contact customer service for shim pack (1118036).

COVER LEAKS WATER:

- Cover is not designed to be fully water tight.
- Make sure clamps are tight and rails are positioned correctly.
- Extra seal can be added to help block water intrusions.

TOP OF COVER POOLS WATER:

- Certain amount of water pooling is normal with fabric covers.

- The cross tubes are not arched, therefore some water pooling may occur and is normal. This will not affect performance or the water management properties in this fabric.

- Make sure cover is pulled tight on each side and automatic tension control is properly adjusted.

COVER ROLLS UP CROOKED:

- Make sure control straps are evenly set. See Step 13.

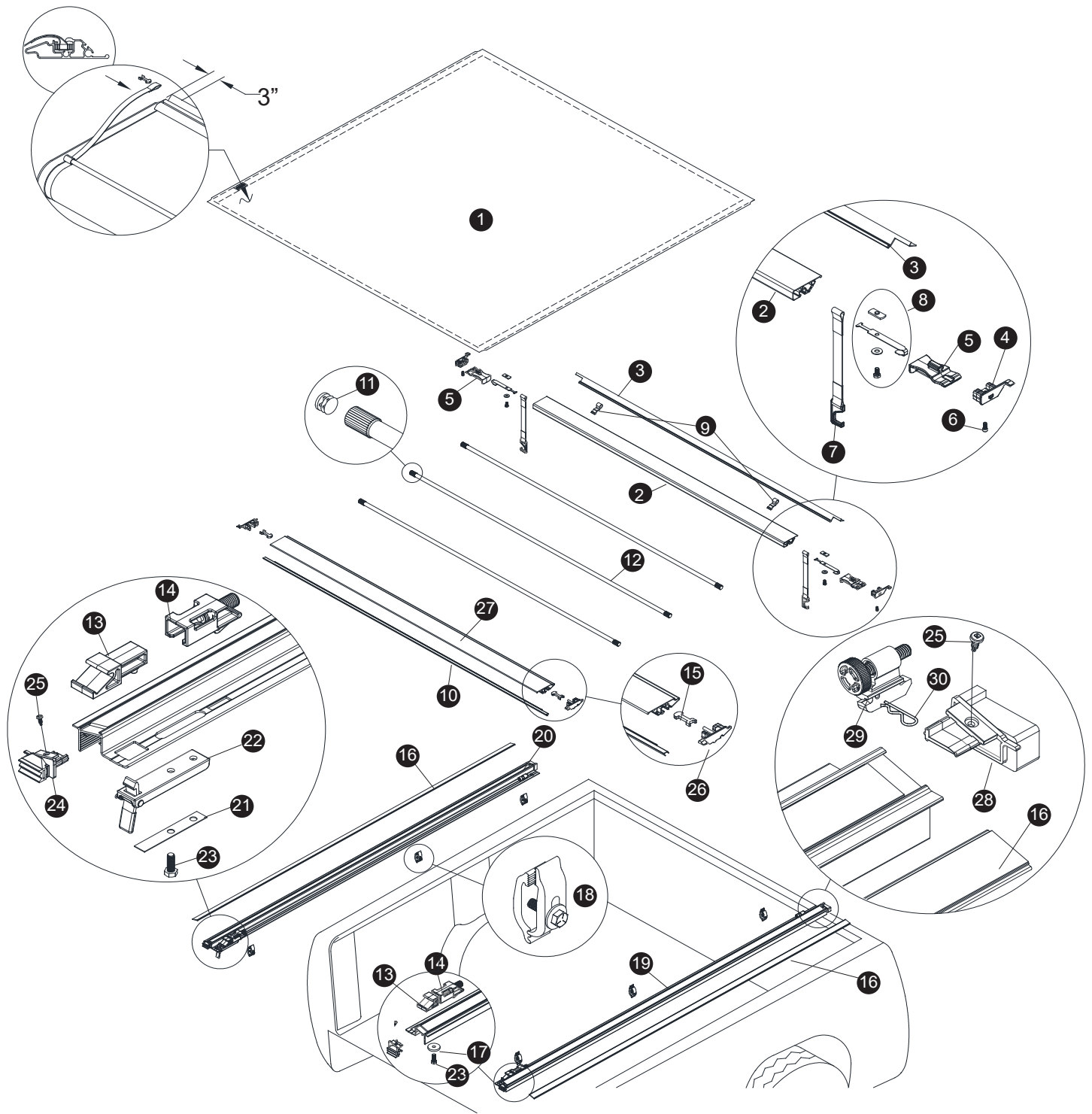

TruXedo® Pro X15 Replacement Parts

1	*	TruXedo® Pro X15 Replacement Cover	11	1705052	End Plug, 1" OD	19	*	Pro X15 Rail, Passenger's Side
2	*	Black Front Header	12	*	Aluminum Cross Tubes	20	*	Pro X15 Rail, Driver's Side
3	*	Header Seal Front	13	1704660	Header Stop	21	1705727	Flat Spring, 5/8" x 3 7/8"
4	1118191	Front Header End Plugs ProX15 (Set of Two)	14	1704658	Tension Control Housing & Spring Tension	22	1704213	Latch Assembled
5	1704707	Header Guide	15	1705787	Header Insert Retainer Clip	23	1702926	Cap Screw, 5/16" x 7/8"
6	1704689	Machine Screw 1/4-20 X 9/16"	16	*	Hook and Loop Fasteners	24	1118193	Rear Side Rail End Plugs w/Seal Pro X15 (Set of Two)
7	*	Retainer Strap	17	1704709	Washer Plastic 5/16dia x 1.25 Rd	25	1705629	Square Head Screw (#1 Drive)
8	1117594	Header Guide Retainer Assembly	18	1705392	Aluminum Clamp Single (1)	26	1118192	Rear Header End Plugs Pro X15 (Set of Two)
9	*	Extruded Retainer Loop		1705391	Aluminum Clamp Pack (6)	27	*	Black Rear Header
10	*	Header Seal Rear				28	1118248	Front Side Rail End Plugs w/Seal Pro X15 (Set of Two)
						29	1705585	Front Header Stabilizer
						30	1703332	Pin, Hitch_1/16" Dia.x 1-5/16" long.

* Please specify length or make and model of vehicle.

[View other tonneau covers made by TruXedo on our website.](#)