

TRIPLE-R
HIGH PERFORMANCE LIGHTING

LR-1000 ELITE

The LR Series is borne out of extensive testing at the highest levels of professional track and rally motorsport, the LR Elite represents the pinnacle of LED driving light technology. The best just got better, with the incorporation of the very latest high efficiency LED technologies, used in combination to deliver more distance illumination and more left/right spread of light, guaranteed to impress across all road or motorsport applications. Subtle styling updates have resulted in a clean contemporary design, with a more aggressive edge, to match the aesthetic design prevalent on modern vehicles.

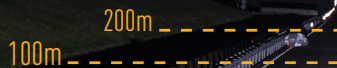

UK BUILT | US DRIVEN

LR SERIES

- Ultra long-range optics optimised for road and race applications
- High intensity LED's deliver exceptional luminosity and left/right spread
- Component technology shared with WRC lighting solutions
- CAE optimised heatsink
- Electronic thermal management
- 'Unbreakable' polycarbonate lens with hardcoat

Horizontal: 42° / Vertical: 13° (2% of peak)

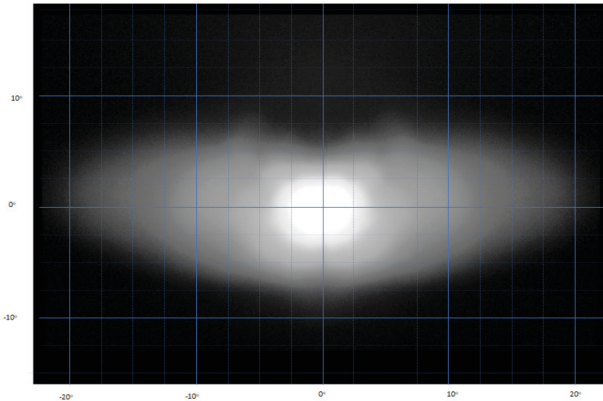

LR-1000 ELITE

Generated from bsi lamp photometric test data: on road measurement data

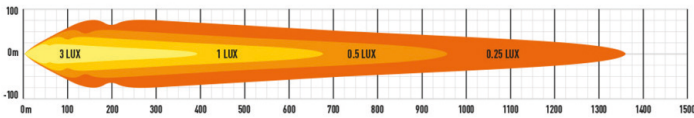

| | |
|------------------------|-------------|
| VOLTAGE RANGE | 10V - 32V |
| RAW LUMENS | 10,136 |
| BEAM PATTERN | Spot |
| BEAM DISTANCE (0.25LX) | 1358 |
| # HIGH POWER LEDS | 8 |
| POWER CONSUMPTION | 104 Watts |
| CURRENT DRAW† | 7.2 Amps |
| LED LIFE | 50,000 Hrs* |
| WEIGHT | 1700g |

*LED Manufacturers Specifications †At 14.4 Volts

MOUNTING OPTIONS

CENTRE MOUNT



SIDE MOUNT KIT
(sold seperately)

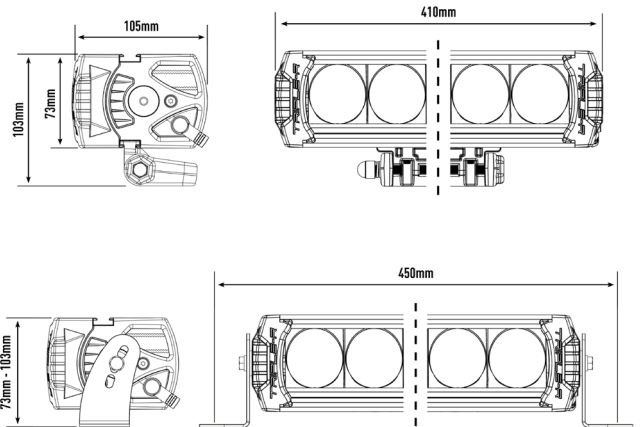

Triple-R Lights LLC, 16192 Coastal Highway, Lewes, Delaware, 19958, USA | sales@triple-r-lights.com | www.triple-r-lights.com

