

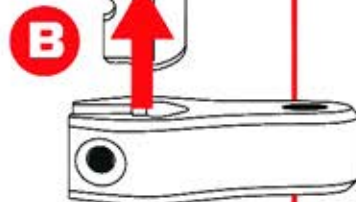

Adjustable Hitch System

Razor Hitch Installation

Slide Drop Bar into receiver box and lock securely with your pin & clip or **TRIMAX™** receiver pin lock.

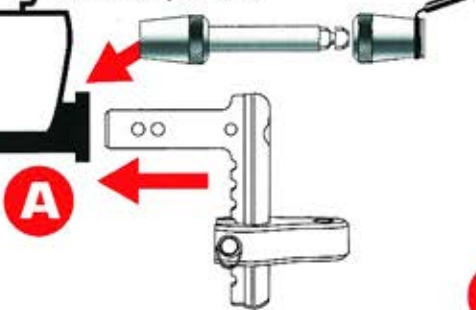

Slide ball mount onto drop bar and move to the desired height.

Once desired height is located insert locking pin and secure with clip.

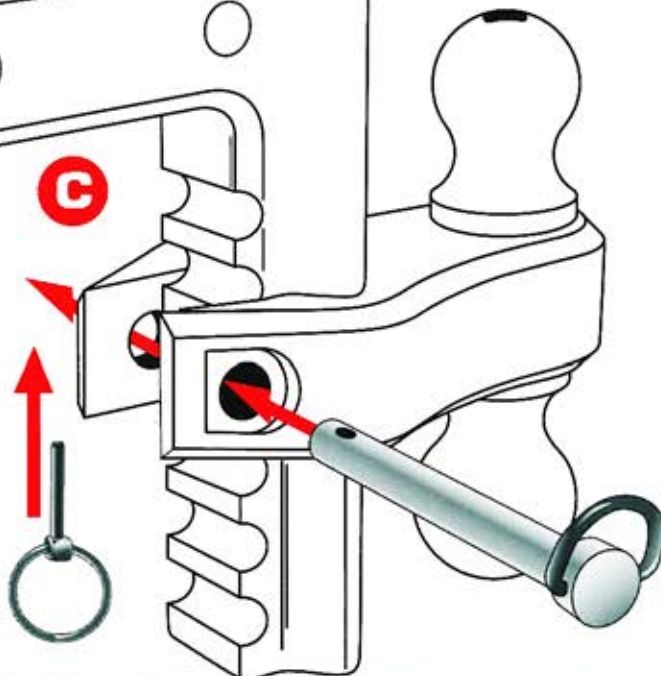

Tow Ball Installation

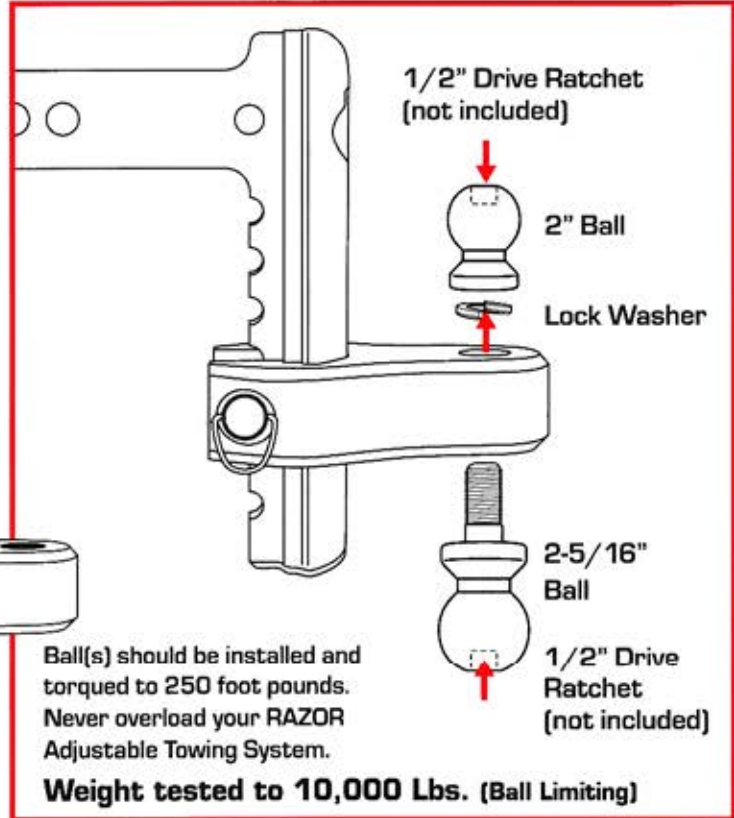

Ball(s) should be installed and torqued to 250 foot pounds. Never overload your RAZOR Adjustable Towing System.

Weight tested to 10,000 Lbs. (Ball Limiting)

! Never Exceed Weight Limit Of Your Tow Ball !

Available:

TRZ52

Keyed Alike Lock Pin Set for added security.

Includes:

- 1) 1/2" Dia. x 3-5/8" Span Ball Mount Pin.
- 1) 5/8" Dia. x 3-1/2" Span Receiver Pin.



DO NOT OPERATE RAZOR HITCH WITHOUT CORRECTLY AND SECURLY FASTENING PIN AND CLIP!





Grease Reservoir

Ball(s) should be installed and **torqued to 250 foot pounds.**

After installation, fill 1/2" drive sockets with a quality bearing grease, which can be dipped out and used to grease ball surface during towing.

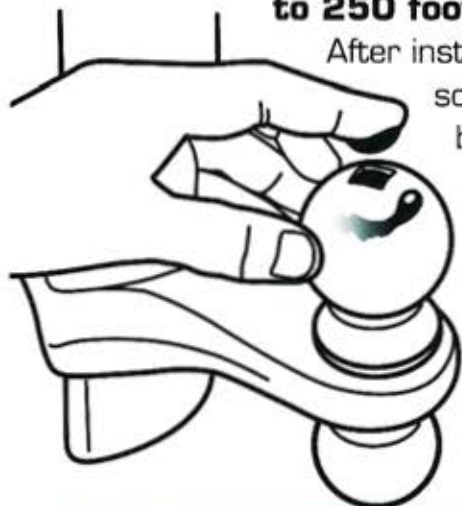

Added Rise/Tow Ball Choice

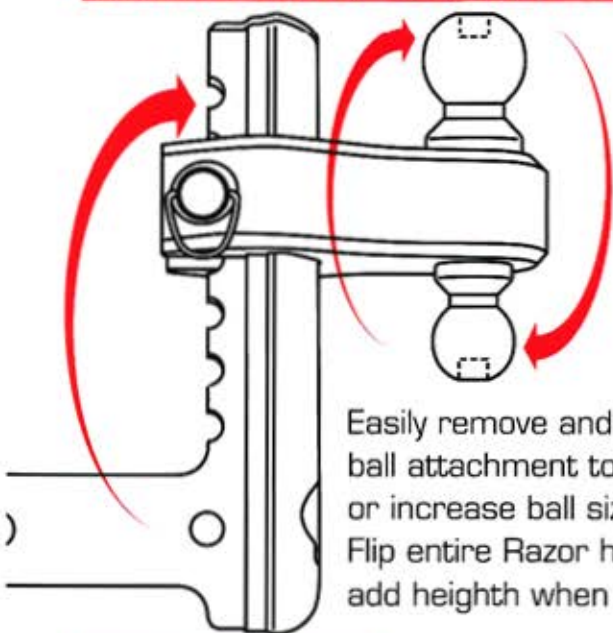

Easily remove and flip double ball attachment to decrease or increase ball size. Flip entire Razor hitch to add height when needed.

CAUTION!!!

Never overload your RAZOR Adjustable Towing System. Weight tested to 10,000 Lbs. **NEVER EXCEED WT LIMIT OF YOUR TOW BALL.** Always use standard towing procedures and follow supplied check list.

CHECK LIST, Before You Drive

Make sure your vehicle and trailer maintenance are up to date before you drive. Review this easy to use check list to ensure a safe trip every time.

- Check tire pressure on tow trailer and vehicle before use. Correct if needed.
- Lug nuts/bolts on tow trailer and vehicle should be tightened to correct torque.
- Properly secure and adjust hitch, coupler, draw bar and other equipment that connect the trailer and tow vehicle.
- Is wiring properly connected? Wiring should not touch the road but be loose enough to make turns without causing damaging or come disconnected.
- Are all running lights, brake lights, turn signals, and hazard lights in good working order?
- Check brakes on tow vehicle and trailer should be in good working order.
- All items on and in trailer should be securely fastened.
- Trailer jack, tongue support, and any attached stabilizers should be raised and locked in place.
- Review load distribution. Make sure the tow vehicle and trailer load is properly distributed side to side and front to back.
- All mirrors should be set for good visibility.
- Review routes and restrictions on bridges and tunnels.
- Include wheel chocks and jack stands.



DO NOT OPERATE RAZOR HITCH WITHOUT CORRECTLY AND SECURELY FASTENING PIN AND CLIP!

