

## Assembly

- 1 Apply two drops of thread adhesive to the stem of each caster and then, using a T40 TORX 6 lobe star key wrench, attach the four casters to the X-Frame using the four washers and barrel nuts.

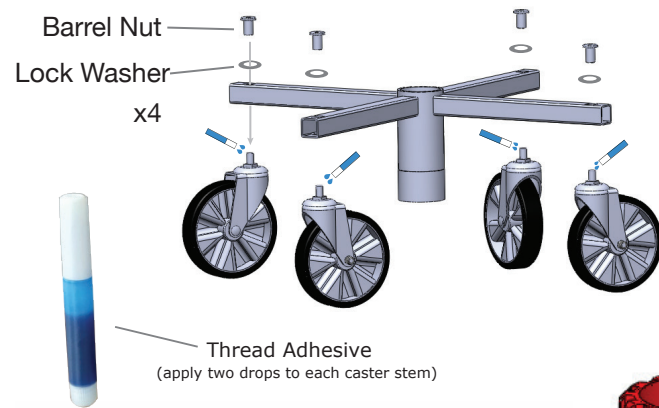

### IMPORTANT

Very important that the lock washer is compressed completely flat. Be **EXTREMELY CAREFUL** not to over-tighten and deform tube.

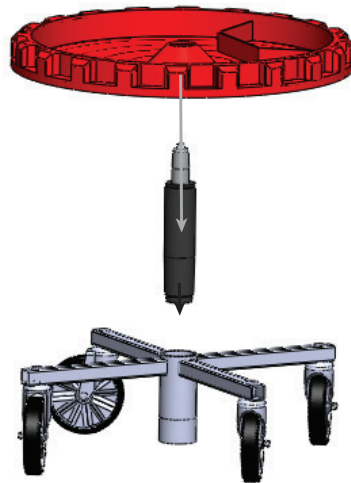

- 2 Slide the pneumatic cylinder into the X-Frame drop sleeve. Slide the spinning Gear Tray onto the cylinder.

- 3



Slide the Racing Seat base onto the top of the pneumatic cylinder. Frame, cylinder and seat will all press fit together.

## Usage

### Adjusting the Racing Seat Height

While sitting on the seat pull up on the height adjustment lever to lower the seat height. To raise the seat lift your weight off the seat and pull up on the lever.

