



***In-Bed Auxiliary Tanks
Refueling Tanks
Fuel Tank & Tool Box Combos
Replacement Tanks***



Welcome to Our Family

A Message From Our CEO

We are excited to welcome you into the Transfer Flow family with fellow truck owners who have discovered our premier fuel systems are engineered for excellence.

Your time is important to us. Fueling your adventures is our mission. Your new Transfer Flow fuel tank will reduce your fuel stops and get you to your destination faster than ever.

Your investment is important to us. Making sure you are well taken care of is our promise. You will have access to our industry-leading customer service team day or night.

Your success is important to us. Providing only the best in aftermarket fuel tanks is our purpose. You will succeed on the road in a safe, legal, and reliable manner.

YOU are the most essential part of our success, and we thank you for trusting us to fuel your driving needs.

Lisa Johnson

Lisa Johnson, CEO

Transfer Flow Fuel Tanks Come with a 6-Year Warranty

Transfer Flow fuel systems and vehicle accessories are covered by a six year, unlimited mile warranty against defects in material and workmanship throughout the U.S. and Canada from the unit purchase date by the original purchaser for the original vehicle the unit was installed in.



Contents

- 1 From Our CEO
- 1 Warranty
- 2 Ordering Information
- 3 Fuel Tank Categories
- 4 TRAX 4™ Operating System
- 5 In-Bed Auxiliary Fuel Tanks
- 9 Refueling Tank Systems
- 13 Diesel Refueling Tanks
- 15 Auxiliary Tank & Tool Boxes
- 19 Refueling Tank & Tool Boxes
- 23 Pickup Replacement Tanks
- 24 Ford Pickup Replacement Tanks
- 25 GM/Chevy Pickup Replacement Tank
- 26 Toyota Tundra Replacement Tank
- 27 Cab Chassis Replacement Tanks
- 28 Ford Cab Chassis Replacement Tank
- 29 Ram Cab Chassis Replacement Tanks
- 30 Fuel System Regulations

On the Cover

The Baja Forged Super Duty is an all-in-one overland themed mobile command center, workshop and campsite and was designed and built by LGE-CTS Motorsports facility in San Dimas, California. The Ford F250's fuel capacity and driving range was increased with the installation of Transfer Flow's 60-gallon midship replacement fuel tank system!



Premier Fuel Tanks for Every Need



Our tank systems are crafted with the finest U.S. materials, including 12- and 14-gauge high-yield U.S. aluminized steel (powder coated for a durable finish) or aluminum diamond plate.



Replacement Fuel Tanks

Eliminate half your fuel stops by replacing the stock fuel tank with a high-capacity Transfer Flow replacement fuel tank system that doesn't sacrifice bed space or ground clearance.



In-bed Auxiliary Fuel Tanks

Extend your range with additional fuel in the bed of your truck. Our TRAX 4™ computer-controlled auxiliary fuel tank systems automatically transfer fuel to the main tank.



Refueling Tanks

Refuel vehicles and equipment with an in-bed transfer fuel tank. Department of Transportation (DOT) legal, our refueling tanks are engineered for gas, diesel, ethanol/methanol, and kerosene.



Tool Box Tank Combos

For extra fuel and extra storage, we have auxiliary and refueling tool box combination systems. Each tool box fuel tank is equipped with locking handles to keep your tools and gear safe and secure.



Retrofit Filler Neck Kits

Whether for a pickup box delete, a utility body, or a cab chassis work truck, each filler neck kit is engineered for a specific vehicle.



Accessories

For additional convenience, we offer a number of fuel tank accessories including locking fuel caps, diesel biocide, fuel filters, digital fuel meters, tie down brackets, and more.

For Worry-free Fuel Transfers, You Can Trust Transfer Flow's TRAX 4™ Fuel Management System

Know how many miles to go until empty

Shows operating status, including when fuel is being transferred

Fuel levels shown in each tank

Gallons shown in each tank (or you can choose to show percentage)

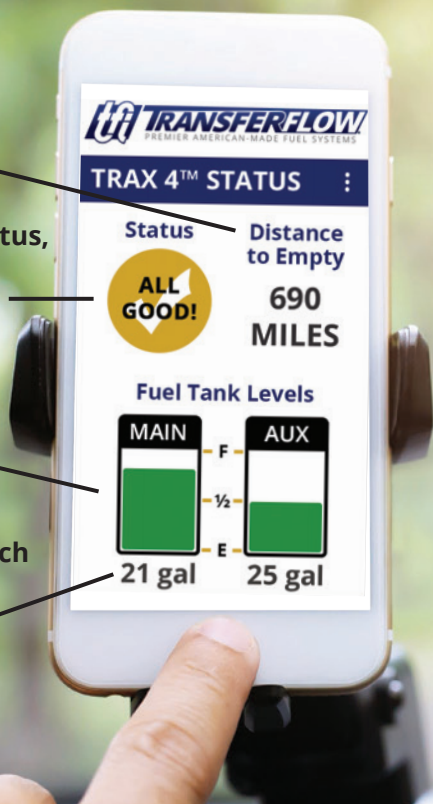





The next generation of our auxiliary fuel tank operating system is here! TRAX 4™ is a computer-controlled fuel management system that transfers fuel from a Transfer Flow auxiliary fuel tank to your pickup's main fuel tank. TRAX 4™ comes with all Transfer Flow auxiliary fuel tanks.

Based on the capacity of your pickup's main fuel tank and the capacity of the Transfer Flow auxiliary fuel tank, the TRAX 4™ system will transfer fuel at predetermined levels while the vehicle is in operation.

Want to know the status of your onboard fuel systems? Download the TRAX 4™ mobile app to your smartphone and enter your vehicle and fuel system information. You'll be able to monitor your pickup's fuel capacity in no time! During fuel transfer, the message "PUMP ON" will be displayed on your smartphone. You also have the option of displaying either the gallons or the percentage of fuel in each tank.

Phone and phone holder not included.

TRAX 4™ Status Guide

| | | | | | | | | | |
|--|--|---|--|---|--|--|--------------------------------------|---|---|
|  | The vehicle's fuel systems are functioning properly. |  | Fuel transfer from the auxiliary tank to the main tank is occurring. |  | There is an error with the vehicle's fuel systems. See TRAX 4™ manual. |  | Blue tooth connection has been lost. |  | Vehicle engine is off. Start engine to access data. |
|--|--|---|--|---|--|--|--------------------------------------|---|---|

OPTIONAL ITEM

Monitor the Fuel Level of Your Auxiliary Fuel Tank with an In-Cab Display

If you prefer not to use our TRAX 4™ app with your auxiliary tank but still want to know how much fuel is in the tank, consider our in-cab fuel level monitor LCD. The LCD shows the fuel level of the auxiliary tank with an easy-to-read bar graph that decreases when fuel is transferred to the pickup's main fuel tank. This item is sold separately.



Fuel Level Monitor LCD (shown actual size)
part no. 040-01-17100

Gravity-Fed Systems are Unsafe and Unlawful

Due to safety, environmental, and legal concerns, Transfer Flow does not endorse, design, install, or sell gravity-fed fuel systems because of their inherent risks. With gravity-fed systems, if the valve, connectors, or fuel line malfunctions (or you forget to close the valve), there's nothing to prevent over-filling the fuel tank and causing dangerous fuel spills. By installing a gravity-fed system, you are disabling the safety features of your vehicle's fuel system. Transfer Flow fuel tanks are never to be used in conjunction with gravity-fed systems.



Long hauls are worry-free with additional onboard fuel

Transfer Flow in-bed auxiliary fuel tanks provide a worry-free, no-hassle experience with our patented TRAX 4™ computer-controlled fuel management system.



Each of our auxiliary fuel tanks come with our TRAX 4™ system and mobile app that shows fuel levels in percentages or gallons, as well as the operational status of the system.

Our AutoTrans® technology is specific for each vehicle and auxiliary tank model, and automatically transfers fuel from the in-bed tank to the main tank at specified fuel levels.

Our in-bed auxiliary fuel tanks are available in 37-, 40-, 50-, 75-, and 100-gallons. Each fuel tank comes with our TRAX 4™ operating system and mobile app that shows fuel levels in percentages or gallons and the system's operational status.

FEATURES & BENEFITS

- Robot-welded seams provide extraordinary strength
- Comes complete with all components for installation
- TRAX 4™ computer-controlled automatic fuel transfers for worry-free operation
- Built from ReliaSteel®, high-yield U.S. aluminized steel, for superior durability and strength
- Baffled to prevent fuel sloshing
- 6-year, unlimited mile warranty



NOTES

- ✘ 2010—12 Ram Mega Cab and Crew Cab short bed pickup with single rear wheels require a filler neck (part no. 050-01-15461).
- ✚ 2013—21 Ram Mega Cab and Crew Cab short bed pickups require a mounting bracket kit (part no. 020-01-16790).
- ✚ Will not fit on 2013—21 Ram short bed with 5th Wheel Prep Package.
- ◆ 2016—21 Chevy Colorado pickups require auxiliary vent line kit (part no. 020-01-16777).
- ✦ Does not fit on 2020—21 Ram short bed pickup.

OPTIONAL UPGRADES & ACCESSORIES



TRAX 4™ Fuel Level Monitor
040-01-17100



Killem® Biocide
070-CH-33291



Locking Fuel Cap
070-GC-33572



Tie Down Brackets
020-01-16384

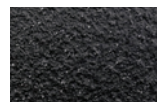

Spray-On Textured Coat

• Fits under most retractable bed covers and tonneau covers



37
GALLON

**SHORT AND
LONG BED**

Fits: 2008—2021 Ford and Dodge/Ram, 2009—2021 GM/Chevy

Fuel: Diesel

Ship Weight: 142 lb.

Dimensions: 53" L × 21 1/8" W × 18" H

Part Number (Black Powder Coat): 080-01-16180

Part Number (Textured Coat): 080-BL-16180

Notes: ✕ +

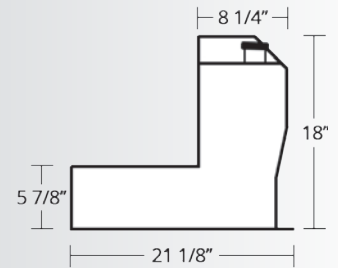

- Fits under most tonneau covers
- Works with 5th wheel prep packages
- Fits Chevy Colorado and GMC Canyon diesel trucks

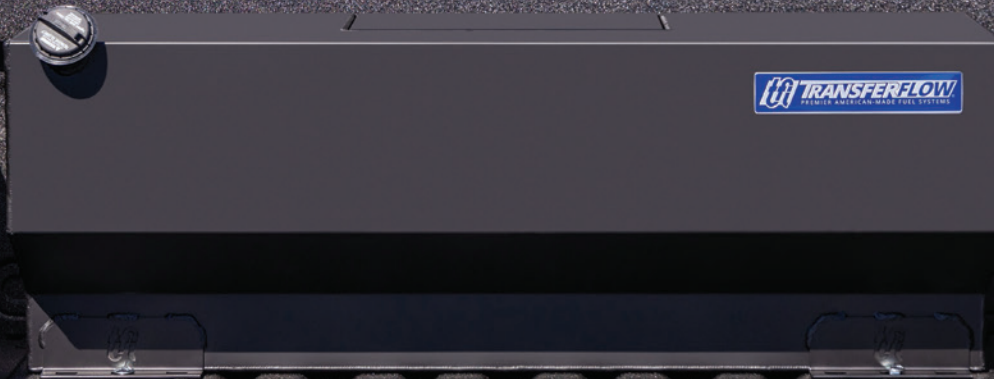

40
GALLON

**SHORT AND
LONG BED**

Fits: 2008—2021 Ford and Dodge/Ram, 2009—2021 GM/Chevy

Fuel: Diesel

Ship Weight: 132 lb.

Dimensions: 48" L × 19" W × 19 3/8" H

Part Number (Black Powder Coat): 080-01-16637

Part Number (Textured Coat): 080-BL-16637

Notes: ✕ ❄️ ◆

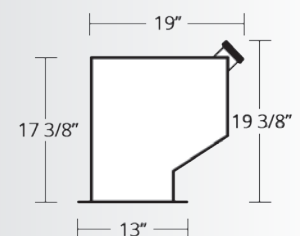

• Fits under most tonneau covers



50
GALLON

**SHORT AND
LONG BED**

Fits: 2008—2021 Ford and Dodge/Ram, 2009—2021 GM/Chevy

Fuel: Diesel

Ship Weight: 155 lb.

Dimensions: 60 3/4" L × 18 1/2" W × 18" H

Part Number (Black Powder Coat): 080-01-16625

Part Number (Textured Coat): 080-BL-16625

Notes: ✕+



75
GALLON

**SHORT AND
LONG BED**

Fits: 2008—2021 Ford and Dodge/Ram, 2009—2021 GM/Chevy

Fuel: Diesel

Ship Weight: 182 lb.

Dimensions: 60 3/4" L × 21" W × 22 1/2" H

Part Number (Black Powder Coat): 080-01-16755

Part Number (Textured Coat): 080-BL-16755

Notes: ✕+✦



100
GALLON

LONG BED

Fits: 2008—2021 Ford and Dodge/Ram, 2009—2021 GM/Chevy

Fuel: Diesel

Ship Weight: 264 lb.

Dimensions: 60 3/4" L × 27 1/4" W × 22 3/8" H

Part Number (Black Powder Coat): 080-01-16758

Part Number (Textured Coat): 080-BL-16758

Notes: ✖ +

// From ordering to delivery, communication from Transfer Flow and the shipping company was excellent. You get what you pay for, as the saying goes, and this tank is certainly American-made quality! //



by KEITH TIGHE

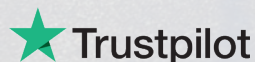



Fuel up equipment, vehicles, and off-road toys with a legal refueling tank

Ditch the fuel cans when you have a refueling station in your truck bed that's perfect for refueling vehicles, off-road toys, and equipment.

Transfer Flow refueling tank systems are Department of Transportation (DOT) legal to carry and transfer gasoline, diesel, ethanol, methanol, and kerosene. The easy-to-use hose purging feature pulls any remaining fuel left in the hose back into the refueling tank to eliminate fuel messes and stretch your extra fuel capacity even further. Includes GPI® fuel pump.

See page 30 for refueling tank regulation information.

OPTIONAL UPGRADES & ACCESSORIES

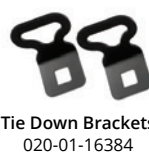
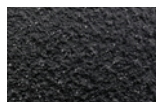

FEATURES & BENEFITS

- Comes with 12-volt GPI fuel pump, 12 ft. hose, nozzle, fuel cap, wiring harness with cab-mounted power switch, and mounting hardware
- DOT legal for gasoline, diesel, methanol, ethanol, and kerosene
- Built from 12-gauge ReliaSteel®, high-yield U.S. aluminized steel, for superior durability and strength
- Powder coated black for durable satin finish
- Easy-to-use hose-purge feature eliminates messes
- Pumps up to 15 gallons per minute (8 GPM with 40-gallon refueling tank)
- Baffled to prevent fuel sloshing
- 6-year, unlimited mile warranty



NOTES

- ✦ This tank will not fit on 2013—21 Ram short bed pickups with 5th Wheel Prep Package.
- ✦ 2013—21 Ram Mega Cab short bed pickups require a mounting bracket kit (part no. 020-01-16790).



• Fits under most tonneau bed covers

**40
GALLON**

**SHORT AND
LONG BED**

Fits: All Light and Heavy Duty Trucks, Jeep Gladiator
Fuel: Gasoline, Diesel, Kerosene
Ship Weight: 190 lb.
Dimensions: 40" L x 23" W x 17 1/8" H
Part Number (Black Powder Coat): 080-01-16206
Part Number (Textured Coat): 080-BL-16206
Note: +

FUEL GAUGE OPTION

Fuel Gauge:
070-GA-34240



**50
GALLON**

**SHORT AND
LONG BED**

Fits: All Full-Size Trucks
Fuel: Gasoline, Diesel, Kerosene, Methanol/Ethanol
Ship Weight: 206 lb.
Dimensions: 54 3/8" L x 15 1/2" W x 24" H
Part Number (Black Powder Coat): 080-01-09417
Part Number (Textured Coat): 080-BL-09417
Notes: +★

FUEL PUMP & GAUGE OPTIONS

Methanol/Ethanol Pump:

080-MP-09417

Fuel Gauge:

070-GA-34241



**82
GALLON**

**SHORT AND
LONG BED**

Fits: All Full-Size Trucks
Fuel: Gasoline, Diesel, Kerosene, Methanol/Ethanol
Ship Weight: 251 lb.
Dimensions: 47 3/4" L x 22 5/8" W x 26 5/8" H
Part Number (Black Powder Coat): 080-01-09420
Part Number (Textured Coat): 080-BL-09420
Note: +

FUEL PUMP & GAUGE OPTIONS
Methanol/Ethanol Pump:
 080-MP-09420
Fuel Gauge:
 070-GA-34242



**100
GALLON**

LONG BED

Fits: All Full-Size Trucks
Fuel: Gasoline, Diesel, Kerosene, Methanol/Ethanol
Ship Weight: 329 lb.
Dimensions: 53 3/4" L x 35 7/8" W x 27 5/8" H
Part Number (Black Powder Coat): 080-01-09418
Part Number (Textured Coat): 080-BL-09418
Note: +

FUEL PUMP & GAUGE OPTIONS
Methanol/Ethanol Pump:
 080-MP-09418
Fuel Gauge:
 070-GA-34242

• Available with tool box (page 21)



**109
GALLON**

LONG BED

Fits: All Full-Size Trucks
Fuel: Gasoline, Diesel, Kerosene, Methanol/Ethanol
Ship Weight: 297 lb.
Dimensions: 54 3/4" L × 30" W × 22 5/8" H
Part Number (Black Powder Coat): 080-01-09416
Part Number (Textured Coat): 080-BL-09416
Note: +

FUEL PUMP & GAUGE OPTIONS

Methanol/Ethanol Pump:

080-MP-09416

Fuel Gauge:

070-GA-34241



**50/50
GALLON**

**SHORT AND
LONG BED**

Fits: All Full-Size Trucks
Fuel: Gasoline, Diesel, Kerosene, Methanol/Ethanol
Ship Weight: 332 lb.
Dimensions: 47 3/8" L × 31" W × 24 3/8" H
Part Number (Black Powder Coat): 080-01-13244
Part Number (Textured Coat): 080-BL-13244
Note: +

• Holds two types of fuel

FUEL PUMP & GAUGE OPTIONS

Methanol/Ethanol Pump:

080-MP-13244

Fuel Gauge:

070-GA-34241



The convenience of a diesel fuel station in the bed of your truck

Fill your fuel needs with a safe, legal, and reliable refueling tank from Transfer Flow! Our diesel refueling tanks are rugged and durability-tested to hold up to daily use.

Transfer Flow's 50- and 80-gallon refueling tanks are legal to carry diesel, a non-combustible fuel. Each tank includes two internal baffles to reduce fuel sloshing and fully-welded mounting brackets.

These refueling tanks are made from 14-gauge U.S. aluminized steel for superior durability and strength, and powder coated black for a durable finish, and come with fuel cap, bolts, nuts, washers, bed shims, and installation instructions. Pumps are sold separately.

OPTIONAL UPGRADES & ACCESSORIES



GPI® 12-Volt
15 GPM Pump Kit
070-FU-34415



Fill-Rite® 12-Volt
15 GPM Pump Kit
070-FU-34417



Husky® Fueling Swivel
070-FS-32685



GPI® Fuel Meter
020-01-13959



Tie Down Brackets
020-01-16384



Fuel Filter Kit
020-01-13958



Locking Fuel Cap
070-GC-34074



Killem® Biocide
070-CH-33291

FEATURES & BENEFITS

- Refueling tank to fuel diesel vehicles and equipment
- Built from 14-gauge U.S. aluminized steel for durability
- Comes with fuel cap, rollover valve, and mounting kit
- Powder coated black for durable finish
- Baffled to prevent fuel sloshing
- 6-year, unlimited mile warranty



NOTES

- + This tank will not fit on 2013–21 Ram short bed pickups with 5th Wheel Prep Package.

Choose a fuel pump

Our diesel refueling tanks are compatible with GPI® and Fill-Rite® fuel pumps. See part numbers below.





**50
GALLON**

**SHORT AND
LONG BED**

Fits: 6.5' and 8' Truck Beds
Fuel: Diesel
Ship Weight: 138 lb.
Dimensions: 54" L x 15.5" W x 23.1" H
Part Number: 070-TK-34310
Note: +

FUEL PUMP OPTIONS

GPI® Fuel Pump:

070-FU-34415

Fill-Rite® Fuel Pump:

070-FU-34417



**80
GALLON**

**SHORT AND
LONG BED**

Fits: All Full-Size Trucks
Fuel: Diesel
Product Weight: 170 lb.
Dimensions: 47" L x 23" W x 25.75" H
Part Number: 070-TK-34311
Note: +

FUEL PUMP OPTIONS

GPI® Fuel Pump:

070-FU-34415

Fill-Rite® Fuel Pump:

070-FU-34417



Enjoy the best of both worlds with extra fuel *and* extra storage

The all-in-one auxiliary fuel tank and tool box combos are computer-controlled by our TRAX 4™ operating system for worry-free fuel transfers.



Each of our auxiliary fuel tanks come with our TRAX 4™ system and mobile app that shows fuel levels in percentages or gallons, as well as the operational status of the system.

Easily load your tools, supplies, and equipment in the locking storage compartment to keep them safe, dry, and secure.

The 40- and 50-gallon fuel tank and tool box combos sit nearly flush with most pickup truck bed rails, while the versatile 70-gallon model sits on the bed rails and adjusts to the depth of the pickup bed.

You can also add refueling capabilities to your Transfer Flow auxiliary fuel tank and tool box combo with the addition of our Refueling Kit!

FEATURES & BENEFITS

- TRAX 4™ computer-controlled automatic fuel transfers for worry-free operation with exclusive AutoTrans® technology
- Comes complete with all components for installation
- Built from high-yield U.S. aluminized steel, or aluminum diamond plate for superior durability and strength
- Gas-filled shocks for easy opening and closing
- Locking handles to keep gear secure
- Baffled to prevent fuel sloshing
- 6-year, unlimited mile warranty



NOTES

- ✖ 2010—12 Ram Mega Cab and Crew Cab short bed pickup with single rear wheels require a filler neck (part no. 050-01-15461).
- ✚ This tank will not fit on 2013—21 Ram short bed pickups with 5th Wheel Prep Package.
- ❖ Does not fit on 2020—21 Ram short bed pickups.

OPTIONAL UPGRADES & ACCESSORIES

| | | | |
|--|---|---|---|
|  |  |  |  |
| TRAX 4™ Fuel Level Monitor 040-01-17100 | Killem® Biocide 070-CH-33291 | Locking Fuel Cap 070-GC-33572 | Locking Black Handles (2) (40 and 70 gal. only) 070-HA-34379 |
|  |  |  |  |
| Refueling Kit (40 and 50 gal.) 020-01-14539 | Refueling Kit (70 gal.) 020-01-16229 | Spray-On Textured Coat (For diesel only) | Tie Down Brackets 020-01-16384 |



Shown with locking black handles upgrade

**40
GALLON**

**SHORT AND
LONG BED**

Fits: 2008—2021 Ford and Dodge/Ram, 2009—2021 GM/Chevy

Fuel: Diesel

Ship Weight: 202 lb.

Outside Dimensions: 59" L × 21" W × 21" H

Inside Dimensions: 59" L × 18" W × 9 3/4" H (6 cu. ft.)

Storage Space: 6 cubic feet

Part Number (Black Powder Coat): 080-01-16188

Part Number (Textured Coat): 080-BL-16188

Notes: ✖ +



**50
GALLON**

LONG BED

Fits: 2008—2021 Ford and Dodge/Ram, 2009—2021 GM/Chevy

Fuel: Diesel

Ship Weight: 236 lb.

Outside Dimensions: 61 3/4" L × 27 1/2" W × 20 1/8" H

Inside Dimensions: 61 3/4" L × 27 1/2" W × 8 3/4" H

Storage Space: 9 cubic feet

Part Number: 080-01-16187

Notes: ✖ +

• Patented design adjusts to truck bed depth



70
GALLON

SHORT AND
LONG BED

Fits: 2008—2021 Ford and Dodge/Ram, 2009—2021 GM/Chevy

Fuel: Diesel

Ship Weight: 280 lb.

Outside Dimensions: 73" L x 24 1/2" W x 23 3/4"-27 3/4" H

Inside Dimensions: 62" L x 14 1/2" W x 9 1/2"-13 1/2" H (9 cu. ft.)

Storage Space: 9 cubic feet

Part Number (Black Powder Coat): 080-01-16063

Notes: ✖ + ✦

// I have the 50-gallon fuel tank and tool box combo on my Ram 3500. I did not hesitate in departing on a 3,400-mile road trip with the confidence the installation was going to work and it did. Being able to stop at the best price diesel truck stops is an extra savings bonus. I would highly recommend this product. //



by LOUIE ASTORGA

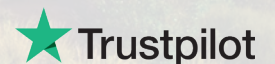



“ If you pull an RV or haul long distances, you need a Transfer Flow tank, period! Having an auxiliary tank allows you to find the cheapest fuel along the route. It also allows you to find the stations where you can pull your rig in easily. Plus, it adds value to your vehicle! ”



by TFI CUSTOMER

Trustpilot



Secure your gear and fuel in a refueling tank and tool box combo

We've designed a refueling station with room to keep your supplies and gear secure. The tool box is equipped with locking handles and gas-filled shocks that make it easy to open and close.



All fuel systems ship with all parts needed for installation and use.

The patented 70-gallon refueling tank and tool box combo pairs the popular over-the-rail tool box style with a versatile adjustable design that ensures the tank fits nicely with appropriate weight support.

Transfer Flow refueling tank systems are Department of Transportation (DOT) legal to carry and transfer gasoline, diesel, methanol, ethanol, and kerosene, and features an easy-to-use purge function that moves remaining fuel in the hose back into the fuel tank.

FEATURES & BENEFITS

- Comes with 12-volt GPI fuel pump, 12 ft. hose, nozzle, fuel cap, wiring harness with cab-mounted power switch, and mounting hardware
- Easy-to-use hose purge feature eliminates messes
- Pumps up to 8 gallons per minute
- Built from 12- and 14-gauge ReliaSteel®, high-yield U.S. aluminized steel, for superior durability and strength
- Baffled to prevent fuel sloshing
- Gas-filled shocks for easy opening and closing
- Locking handles to keep gear secure
- 6-year, unlimited mile warranty



NOTES

- ✚ This tank will not fit on 2013–21 Ram short bed pickups with 5th Wheel Prep Package.
- ✦ Does not fit on 2020–21 Ram short bed pickups.

OPTIONAL UPGRADES & ACCESSORIES

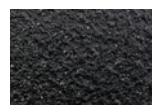

Spray-On Coat
(40 gal. only)



Killem® Biocide
070-CH-33291



Locking Black Handles (2)
(40 and 70 gal. only)
070-HA-34379



Locking Fuel Cap
(100 gal. only)
070-GC-34074



Tie Down Brackets
020-01-16384



**40
GALLON**

**SHORT AND
LONG BED**

Fits: All Full-Size Trucks
Fuel: Gasoline, Diesel, Kerosene
Ship Weight: 215 lb.
Outside Dimensions: 59" L x 21" W x 21" H
Inside Dimensions: 59" L x 18" W x 9 3/4" H
Storage Space: 6 cubic feet
Part Number (Black Powder Coat): 080-01-15195
Part Number (Textured Coat): 080-BL-15195
Note: +



• Patented design adjusts to truck bed depth

**70
GALLON**

**SHORT AND
LONG BED**

Fits: All Full-Size Heavy Duty Trucks
Fuel: Gasoline, Diesel, Kerosene
Ship Weight: 293 lb.
Outside Dimensions: 73" L x 24 1/2" W x 23 3/4"-27 3/4" H
Inside Dimensions: 56 3/4" L x 14 1/2" W x 9 1/2"-13 1/2" H
Storage Space: 9 cubic feet
Part Number (Black Powder Coat): 080-01-16230
Note: + ❖



100 GALLON

LONG BED

Fits: All Full-Size Trucks
Fuel: Gasoline, Diesel, Kerosene, Methanol/Ethanol
Ship Weight: 403 lb.
Dimensions: 53 3/4" L x 35 7/8" W x 27 5/8" H
Inside Dimensions: 50 3/4" L x 20 1/2" W x 13" H
Storage Space: 9 cubic feet
Part Number (Black Powder Coat): 080-01-15457
Part Number (Textured Coat): 080-BL-15457
Note: +

FUEL PUMP OPTIONS
Methanol/Ethanol Pump:
080-MP-15457

// Excellent customer service with equally excellent products. Transfer Flow has the right products to fit all the different applications we have for our trucks and our job sites. //



by BCM CONSTRUCTION





“As a truck accessory retailer, it’s nice to deal with a company that sends you a complete install package along with the product. It made installation much nicer than other brands that we have sold in the past. ”



by YORK MOTORS





Increase your fuel capacity without taking up bed space

Our high-capacity replacement fuel tanks nearly double your fuel capacity so you can cruise without worry.



Replacement tanks have internal baffles for extra durability and strength, and to reduce fuel slosh.

Each replacement fuel tank is made from 12-gauge ReliaSteel®, high-yield U.S. aluminized steel, and is designed to fit in the same space as the stock fuel tank. Simply remove the plastic stock fuel tank, replace it with our complete fuel system, and you're ready to hit the road.

Our replacement tanks are manufactured with internal baffles to reduce fuel sloshing, and come powder coated for a durable satin black finish.

FEATURES & BENEFITS

- Tank sits above the differential, no skid plate needed
- Fits in the same space as stock fuel tank
- Fuel tank mounts inside the frame rail
- Built from 12-gauge ReliaSteel®, high-yield U.S. aluminized steel, for superior durability and strength
- Comes with straps and mounting hardware
- Powder coated with a durable satin black finish
- Baffled to prevent fuel sloshing
- 6-year, unlimited mile warranty



NOTES

- * F-150's equipped with a 23 or 26-gallon stock fuel tank require a replacement sending unit (part no. 070-SE-34254).
- F-150's with a 6 1/2 ft. bed require a Fuel Line Extension Kit (part no. 020-01-17011).
- Only fits long bed SuperCabs equipped with a 34-gallon stock tank.
- ▼ On 2004 model years, this fuel tank system is only available for GM pickups with an LLY engine. Your pickup has an LLY engine if "2" is the eighth digit of the pickup's VIN number.
- ✗ This fuel tank is not available for Tundras registered in California.
- ◆ For 2016—21 model years, this tank will only fit Tundras originally equipped with a 26-gallon stock tank.

OPTIONAL UPGRADE



Spray-On Coat



Killem® Biocide
070-CH-33291



FORD PICKUP REPLACEMENT TANKS

**45
GALLON**

**5 1/2 & 6 1/2 FT BED
SUPERCREW**

Fits: 2018—20 Ford F-150/F-150 Raptor with 3.5L and 5.0L engines only

Fuel: Gasoline

Ship Weight: 186 lb.

Dimensions: 88" L × 17 5/8" W × 19" H

Part Number (Black Powder Coat): 080-01-16947

Part Number (Textured Coat): 080-BL-16947

Notes: *○

**48
GALLON**

**6 1/2 FT BED
CREW CAB**

Fits: 2011—16 Ford F-250/F-350

Fuel: Diesel

Ship Weight: 171 lb.

Dimensions: 62 1/4" L × 14 1/2" W × 18 3/4" H

Part Number (Black Powder Coat): 080-01-16275

Part Number (Textured Coat): 080-BL-16275

**60
GALLON**

**6 1/2 FT CREW &
8 FT SUPERCAB**

Fits: 2017—21 Ford F-250/F-350/F-450

Fuel: Diesel

Ship Weight: 216 lb.

Dimensions: 72 3/4" L × 17" W × 17" H

Part Number (Black Powder Coat): 080-01-16565

Part Number (Textured Coat): 080-BL-16565

Note: ■

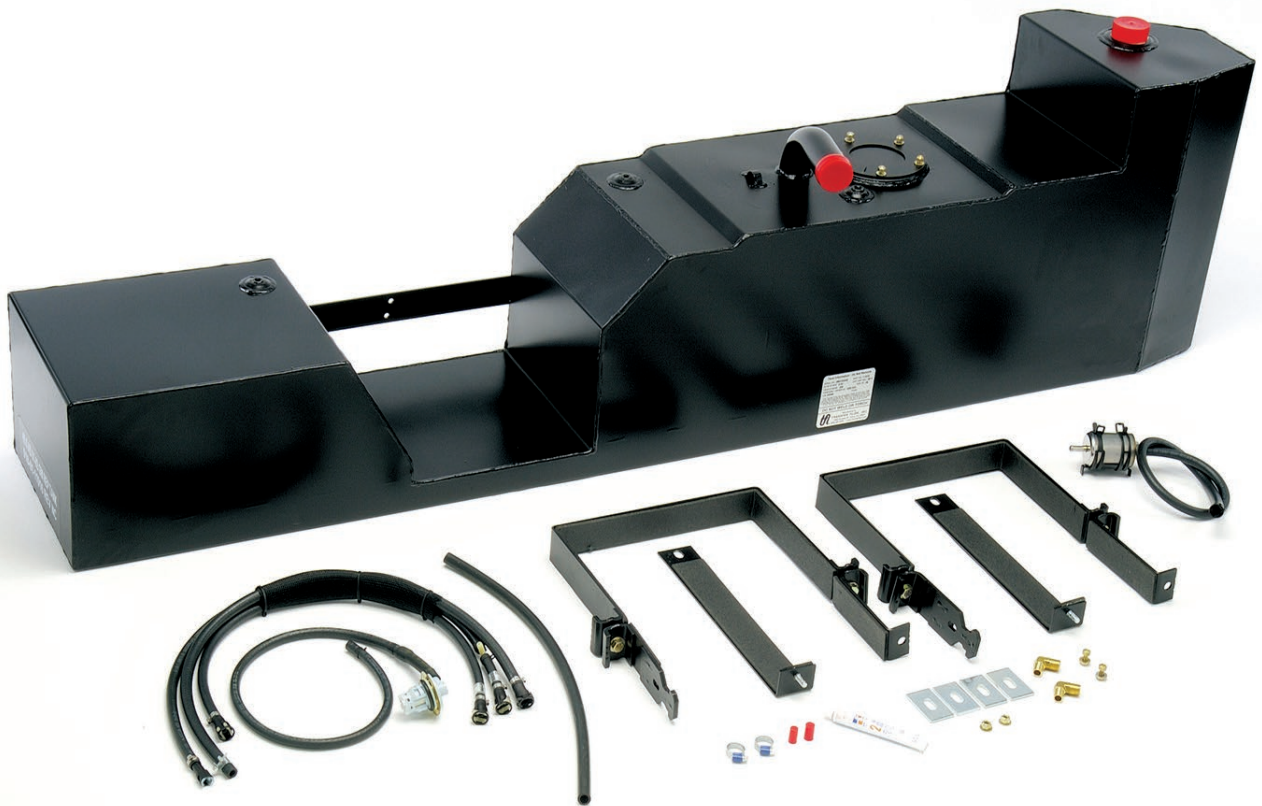

GM/CHEVY PICKUP REPLACEMENT TANK

45
GALLON

**6 1/2 FT BED
CREW/EXT CAB**

Fits: 2004—10 GM/Chevy 2500/3500

Fuel: Diesel

Ship Weight: 198 lb.

Dimensions: 76 3/4" L x 13" W x 19" H

Part Number (Black Powder Coat): 080-01-12755

Part Number (Textured Coat): 080-BL-12755

Note: ▼

/// It's been two long trips with my new Transfer Flow tank. Having the additional fuel makes our long road trips stress free. If you're thinking about this, just do it. You will be very happy with your decision. ///



by BRIAN

 Trustpilot



TOYOTA TUNDRA REPLACEMENT TANK

46
GALLON

**5 1/2, 6 1/2
AND 8 FT BED**

Fits: 2007—20 Toyota Tundra® Double Cab and CrewMax

Fuel: Gasoline

Ship Weight: 187 lb.

Dimensions: 77" L × 17 1/4" W × 12 1/2" H

Part Number (Black Powder Coat): 080-01-14225

Part Number (Textured Coat): 080-BL-14225

Notes: X ◆

/// I installed the 46 gallon tank on my Toyota Tundra and am very happy with the quality. I have been a master automotive technician for 36 years and have seen my share of poorly made products. This is not one of them. ///



by JONATHON LORD

★ Trustpilot



Take your work truck further with a durable replacement fuel tank

Whether you use your vehicle for towing, hauling, or everyday use, replacing your smaller OEM fuel tank with a high-capacity replacement fuel tank system for more onboard capacity and driving range is a must.

Manufactured from 12-gauge ReliaSteel®, high-yield U.S. aluminized steel, our replacement fuel tanks are fitted with internal baffles to reduce fuel sloshing and come powder coated for a durable satin black finish. New straps and mounting hardware is included.

Larger replacement fuel tanks are available for Ford and Ram cab chassis with 60", 84", 108", and 120" Cab-to-Axle (CA) measurements.

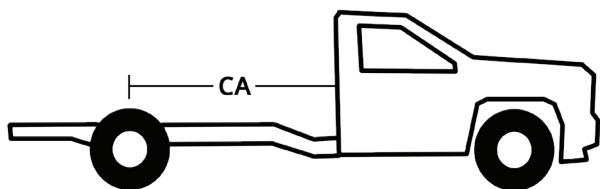

FEATURES & BENEFITS

- Available for 60", 84", 108", and 120" CA measurements
- Fuel tank mounts inside the frame rail
- Tank sits above the differential, no skid plate needed
- Built from 12-gauge ReliaSteel®, high-yield U.S. aluminized steel, for superior durability and strength
- Comes with straps and mounting hardware
- Powder coated for a durable satin black finish
- Baffled to prevent fuel sloshing
- 6-year, unlimited mile warranty



NOTES

- When replacing the aft axle fuel tank with a Transfer Flow midship fuel tank on a Ram cab chassis, an aft axle extension kit is required (part no. 020-01-13920).
- ★ The DEF tank lines will need to be relocated when installing this fuel tank.
- The tank will fit all 60" CA standard cabs with manual shifter and 2x4 with electronic shifter.

OPTIONAL UPGRADE

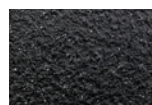

Spray-On Coat



Killlem® Biocide
070-CH-33291

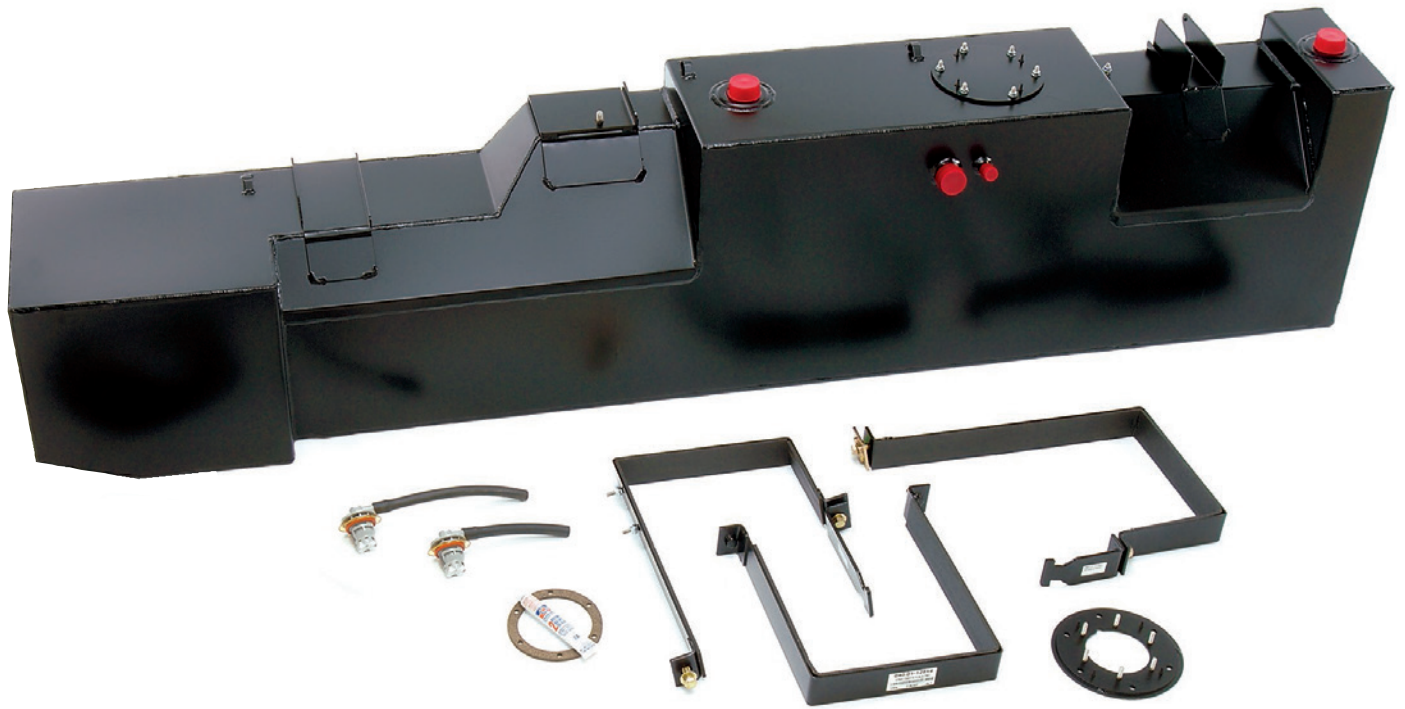

FORD CAB CHASSIS REPLACEMENT TANK

34
GALLON

60"/84"/108"/120"
CAB AXLE

Fits: 1999—2010 Ford F-350/F-450/F-550 Cab Chassis

Fuel: Diesel

Ship Weight: 160 lb.

Dimensions: 76 3/4" L × 13" W × 20 3/4" H

Part Number (Black Powder Coat): 080-01-11001

Part Number (Textured Coat): 080-BL-11001

/// I had a tank installed on my other truck years ago and wanted to do the same on the new truck I recently purchased. I couldn't have hoped for anything better. ///



by STEVE MILLER

 Trustpilot



RAM CAB CHASSIS REPLACEMENT TANKS

**40
GALLON**

60" CAB AXLE

Fits: 2007—20 Ram 4500/5500 Cab Chassis

Fuel: Diesel

Ship Weight: 172 lb.

Dimensions: 74 1/2" L × 11 3/8" W × 17 5/8" H

Part Number (Black Powder Coat): 080-01-15805

Part Number (Textured Coat): 080-BL-15805

Notes: Midship Tank replaces stock midship or aft axle fuel tank ●★○

**50
GALLON**

84" CAB AXLE

Fits: 2007—20 Ram 3500/4500/5500 Cab Chassis

Fuel: Diesel

Ship Weight: 199 lb.

Dimensions: 79" L × 11 3/8" W × 18" H

Part Number (Black Powder Coat): 080-01-15807

Part Number (Textured Coat): 080-BL-15807

Note: Midship Tank replaces stock midship or aft axle fuel tank ●

**50
GALLON**

**108" AND 120"
CAB AXLE**

Fits: 2007—20 Ram 4500/5500 Cab Chassis, 2009—19 Ram 3500 Cab Chassis

Fuel: Diesel

Ship Weight: 203 lb.

Dimensions: 79" L × 11 3/8" W × 18" H

Part Number (Black Powder Coat): 080-01-15809

Part Number (Textured Coat): 080-BL-15809

Note: Midship Tank replaces stock midship or aft axle fuel tank ●

What is a legal fuel tank?

Federal Motor Vehicle Safety Standards (FMVSS) 301 states that anyone who alters a vehicle must meet or exceed the structural integrity and performance of the OEM fuel system. A fuel system includes anything associated with fuel systems such as the fuel tank, filler neck, fuel lines, fuel pump, emission canister, and fasteners. If someone adds an auxiliary system to a vehicle that reduces the fuel system's performance, he or she has violated FMVSS 301 standards. An example of performance reduction could be if fuel from the original system leaked because the auxiliary system was gravity feeding into the original tank. This creates a safety concern as it not only violates FMVSS 301 regulations but is also a hazardous waste problem.

Transfer Flow fuel tanks are safe, legal, and reliable

- Fuel tanks are baffled to prevent fuel slosh
- Fuel tanks are pressure tested for leaks
- Meets emissions regulations of the California Air Resources Board, U.S. Department of Transportation, and the Environment Protection Agency
- Meet CARB and EPA fuel fill rates and regulations
- Meet the fastener (strap) regulations specified by the American National Standards Institute (ANSI) and National Fire Protection Association (NFPA) and required by the Recreation Vehicle Industry Association (RVIA)
- Designed using at least 14-gauge aluminized steel
- Liquid-filled fuel tanks are subjected to a 30 ft. drop test

Our refueling tanks meet United States DOT regulations

The DOT has issued Transfer Flow Special Permit SP-11911 to manufacture and sell refueling tanks to store and transfer gasoline, diesel, ethanol, methanol, and kerosene. Transfer Flow refueling tanks meet or exceed the testing and certification requirements specified in 49 CFR 178.803.

The following guidelines must be adhered to when installing and using a Transfer Flow refueling tank:

- Refueling tanks are designed to be mounted near the head gate in a pickup box, flat bed, or utility box (no other location on the pickup or truck is recommended)
- Transfer Flow refueling tanks must be attended to at all times during loading and unloading by a qualified person as described in 49 CFR 177.834 (i), (3), and (4)
- Refueling tanks must be retested every two years in accordance with 49 CFR 180.352
- Transfer Flow's DOT Special Permit SP-11911 is supplied with every refueling tank, and must be carried aboard each vehicle

Safety Information



Each Transfer Flow fuel tank system is accompanied by a complete set of instructions. These instructions must be followed with no exceptions.

Always follow State and Federal guidelines for the installation of fuel systems. The following requirements must be followed:

- Do not weld or torch any fuel tank or part
- Always check fuel lines for restrictions or kinks; a restriction or kink can result in either fuel returning to the wrong tank or loss of power when pulling heavy loads
- Always use proper venting procedures (gas cap and/or rollover emissions valves) to prevent over-pressurization of the tank
- Never connect a hot wire with 12 volts directly to the sending unit as this will burn up the sending unit resistor
- Never apply more than 3 psi to any Transfer Flow fuel tank
- Do not install filler necks within 3 ft. of any heat source or open flame
- Do not install fuel lines within 3 in. of an exhaust system
- Fuel lines should never be routed on the outside of the vehicle
- Fuel tank information label should never be removed or altered
- Transfer Flow fuel tanks are **NEVER** to be used in conjunction with fuel tanks made by other aftermarket fuel tank manufacturers

Failure to adhere to these requirements will nullify all Transfer Flow warranties and responsibilities.

