



PPART#4406ART#4406
MOTOR MOUNT KIT (Mount Brackets & Pads)

PART#4426
MOTOR MOUNT BRACKETS (NO Pads)

**CHEVY SMALL BLOCK V8 ENGINE INTO A 4-WHEEL DRIVE 1982-1999
 CHEVY S-10/GMC S-15. TH350 OR 700R4 AUTOMATIC TRANSMISSION**

THIS KIT INCLUDES:

Qty.	Part No.	Description	Qty.	Part No.	Description
1	4426	Engine Mount Brackets (pair)	2	HDW421	7/16" Flat Washers
6	HDW366	3/8"-16 x 1" Grade 8 Hex Hd. Bolts	2	HDW422	7/16" Lock Washers
6	HDW321	3/8" Lock Washers	2	HDW053	7/16"-14 Lock Nuts
2	HDW969	7/16"-14 x 5" Grade 8 Hex Hd. Bolts	2	4217	Mount Pads (4406 kit only)

Note: This motor mount kit (or bracket set) is for use during the installation of a Small Block Chevy V8 into the vehicles listed above. The use of properly configured engine mounts is only one of many aspects of this engine swap. Modification to various components (i.e. firewall, transmission crossmember), or the use of special aftermarket products designed for this engine swap will likely be required. This instruction sheet deals with the safe, and proper installation of Trans-Dapt's motor mount kit only. For comprehensive, step-by-step directions, and useful tips for performing this complex project, we recommend the use of a V8 engine swap how-to guide.

**#4406
 INSTALLATION INSTRUCTIONS**

Bolt the new motor mount pads to the stock location on the frame. Do *not* install the brackets directly to the engine at this time. Bolt the mounting brackets to the new pads using the 7/16"-14 X 5" hex head bolts, washers and lock nuts, included with the kit. The bolts go through the rubber mount pads, and the Trans-Dapt Performance mount brackets. Once the mount brackets are bolted to the rubber mounts, the engine can then be positioned into the chassis, and the mounting brackets can be bolted to the engine block for final assembly.

1985-93 MODEL YEARS

1985-93 model frameraills have tapped holes that will make the installation easier. On vehicles that do not have tapped holes, the motor mount pads will have to be installed from the bottom side of the chassis. To securely bolt the pads to the chassis, on vehicles without tapped holes, either disassemble the "A" arm assembly for access, or cut a small access hole on the back side of the crossmember, to provide clearance for both the wrench and nut.

**#4426
 INSTALLATION INSTRUCTIONS**

These Trans-Dapt Performance engine mount brackets install using the stock 2.8 liter V6 engine rubber mount pads.

Install the mounting brackets over the factory V6 pads using the new 7/16"-14 X 5" hex head bolts, washers and lock nuts, included with the brackets. Do *not* install the brackets directly to the engine at this time. The bolts go through the stock rubber pads, and the Trans-Dapt Performance mount brackets. Once the mount brackets are bolted to the stock mounts, the engine can then be positioned into the chassis, and the mounting brackets can be bolted to the engine block for final assembly.

If you are installing the V8 into a 4 cylinder model, you will need a set of Trans-Dapt #4217 mount pads.

Note regarding stock pads: It may be necessary to grind the small metal tabs, located on both sides of your stock 2.8 liter V6 rubber mount pads, to fit the Trans-Dapt Performance mount brackets.

OIL FILTER LOCATION ON ALL 4WD APPLICATIONS (Both 4406 & 4426)

To allow for clearance of the front drive shaft, the stock oil filter must be replaced with an oil filter bypass adapter, and the oil filter relocated to an alternate location in the engine compartment. Trans-Dapt offers two complete kits for this application. The kits include a bypass adapter, remote filter mount, hoses and hardware. Single filter unit #1122. Dual Filter unit #1222.

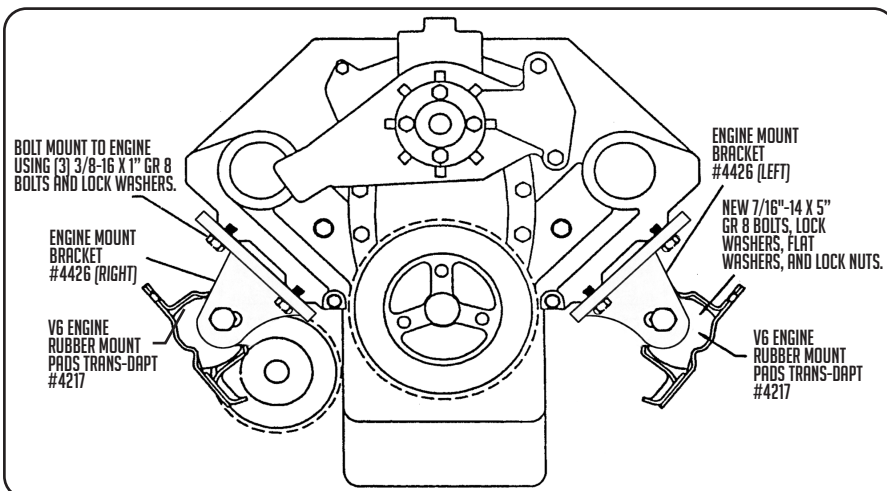

IMPORTANT

This product has been design for a specific application combination. Modifications to any of the components will void the product warranty and return privileges.

For further details regarding other aspects the engine swap, we suggest the use of an aftermarket how-to manual that deals with this specific project.