

## INSTALLATION INSTRUCTIONS for

PART#4175

MOTOR MOUNT BRACKETS (NO Pads)

PART#4195

MOTOR MOUNT KIT (Mount Brackets & Rubber Pads)

PART#4155

MOTOR MOUNT KIT (Mount Brackets & Polyurethane Pads)

## 1958-2002 SB CHEVY V8 (Except LT1) ENGINE INTO 1955-57 CHEVY PASSENGER VEHICLE

### READ BEFORE BEGINNING INSTALLATION

These units are manufactured and offered as an aid in making this conversion. Since no two engine swaps are the same, other changes or modifications may be required. If in doubt, seek professional advice. Trans-Dapt Performance Products is not liable for the misuse and/or the improper use of these mounts. This product is designed to be used with stock engines only. Not for racing applications. It is the responsibility of the owner/ installer to install the engine using safe and proper installation procedures.

### THIS KIT INCLUDES:

Qty.	Part No.	Description	Qty.	Part No.	Description
1	4175 / 4195	Pair of Engine Mount Brackets	1	9525	Pair of Rubber Pads (4195 Only)

### POLYURETHAN KIT (Part# 4155) INCLUDES:

Qty.	Part No.	Description	Qty.	Part No.	Description
1	4175	Pair of Engine Mount Brackets	1	4238	Pair of Polyurethane Pads (4155 Only)

# INSTALLATION INSTRUCTIONS

1. Before removing the stock engine, determine its centerline.

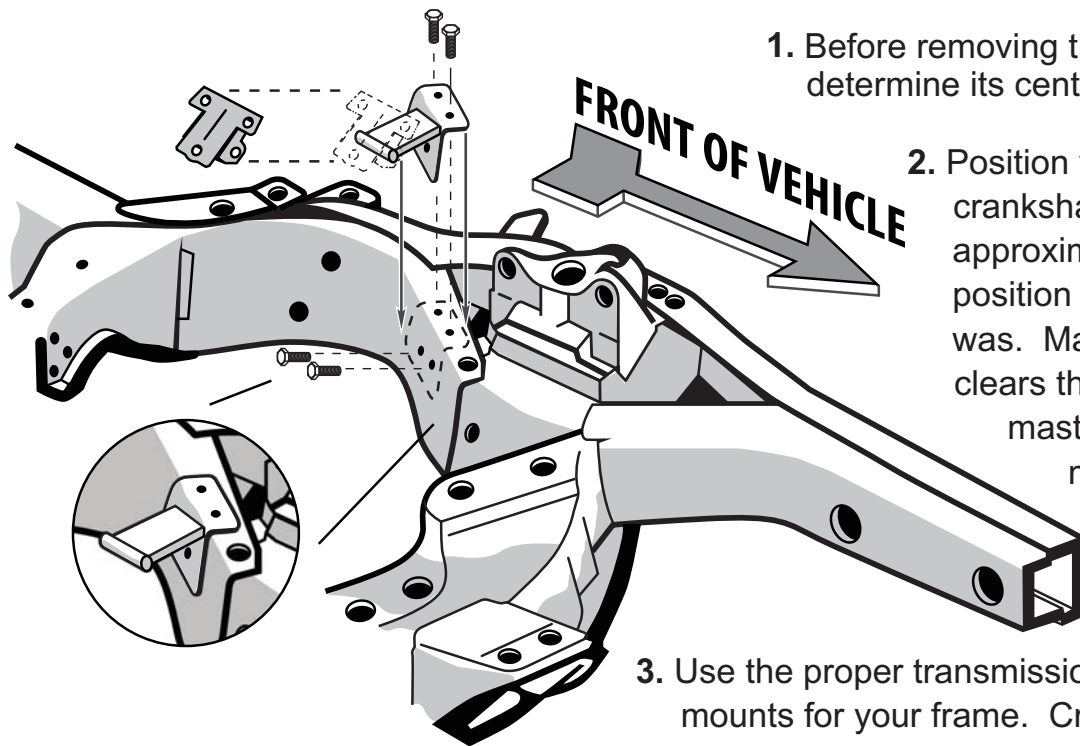

2. Position your engine so the crankshaft centerline is in approximately the same position as the stock engine was. Make sure the engine clears the firewall, steering box, master radiator, etc. with a minimum of cutting for clearance.

3. Use the proper transmission crossmember mounts for your frame. Crossmember #4539 is available through Trans-Dapt Performance, and will fit most 1955-57 Chevy passenger cars except convertibles.

4. These mounts are designed and manufactured to serve as an aid in your conversion. Other changes may be required. If in doubt, seek the advise of a qualified technician.