



PART # 9433

FORD 429-460 MOTOR MOUNT KIT (Not For Lincoln Engines)

This motor mount kit was designed to install the big block 429-460 Ford engine into 1967-69 4WD F-250 Ford Pickup, 1978-79 Bronco and 1978-79 F-150 4WD Ford Pickup.

This kit requires the use of the following Ford Parts:

The following Ford Motor Mounts and Shells from a 1973 to 1979 2WD Ford F250 or F350 with a 460 factory engine.

1 Pair FOMOCO or NAPA motor mounts part #D3TZ6038A

1 each FOMOCO motor mount shells RHS part #D3TZ6030A & LHS part #D3TZ6031A. You may want to try your local Ford dealer or salvage yard for the shells.

PLEASE BE CAREFUL AND USE THE PROPER EQUIPMENT! In order to complete the installation, your truck must be raised a minimum of 36 inches. We recommend the use of a floor hoist. However, if no hoist is available, use axle stands as a safety measure. **NEVER** support your truck with only a bumper jack. A "cherry picker" type engine hoist is necessary to install and position the engine.

INSTALLATION INSTRUCTIONS

1. Disconnect the battery.
2. Disconnect, mark and label all wires, cables and hoses, etc.
3. Remove hood, radiator and engine. If using stock trans., leave it in.
4. Remove the original engine stands from the frame.
5. Using the original engine stand bolts, install the Trans-Dapt motor mount stands on the frame (See figure 1 below). The long stand goes on the left side (driver's side) and the short stand goes on the right side (passenger's side). **DO NOT TIGHTEN BOLTS COMPLETELY.**
6. Bolt the Ford motor mounts and shells to the engine. Shell #D3TZ6031A goes on the left side (driver's side) of the engine. Shell #D3TZ6030A goes on the right side (passenger's side) of the engine.
7. Using an engine hoist, lower the engine into the chassis. Bolt up the transmission to the engine. Then bolt the engine to the motor mount stands. **NOW TIGHTEN ALL BOLTS.**
8. Install the radiator. Connect all cables, wires, etc.
9. We recommend the use of heavy duty front springs to carry the larger engine.

THANK YOU FOR CHOOSING TRANS-DAPT WHEN SELECTING YOUR MOTOR MOUNT KIT. We offer many other items for the 429-460 engine, such as chrome valve covers, air cleaners, oil pan, wire looms, chrome high output coils and more!

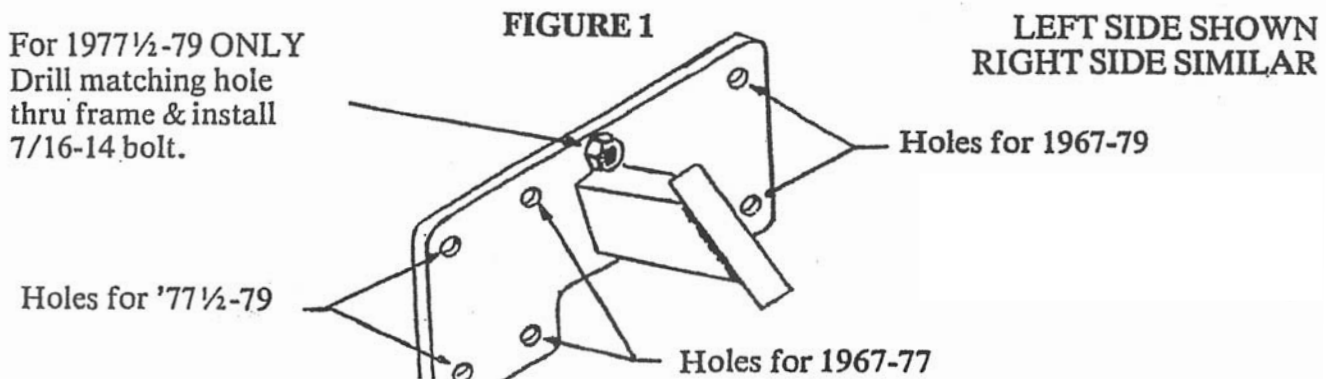

NOTE: ON 1977½-79 MODELS WITH LEAF SPRING FRONT END ONLY, THE HOLES IN THE FRAME DO NOT MATCH THE HOLES IN THE TRANS-DAPT MOTOR MOUNT STANDS. PLEASE FOLLOW THE STEPS BELOW FOR THESE MODELS:

1. Bolt the motor mount stands to the engine.
2. Support the engine and transmission in place in the chassis of the truck.
3. Transfer the existing frame hole locations onto the sideplates of the Trans-Dapt motor mount stands.
4. Drill bolt holes in the sideplates and bolt the stands to the frame. Weld the sideplates to the frame if so desired.