



MOTOR MOUNT KITS

PART #4626 & 4606
Chevy V6 4.3L Engine into a 2WD
S10/S15 Truck and SUV.

Also to add a TH350 Trans. to a stock 2.2
or 2.8L 2WD S10/S15 Truck and SUV.

(4626 WITH PADS)

READ FIRST

These units are manufactured and offered as an aid in making this conversion. Since no two engine swaps are the same, other changes or modifications may be required. If in doubt, seek professional advice. Trans-Dapt Performance Products is not liable for the misuse and/or the improper use of these mounts. This kit is designed to be used with stock engines only, not for racing. It is the responsibility of the owner/ installer to install the engine safely & properly.

THIS KIT INCLUDES:

Qty.	Part No.	Description	Qty.	Part No.	Description
1	9926	Pair of Engine Mount Brackets	2	HDW421	7/16" Flat Washers
6	HDW366	3/8 - 16 x 1" Grade 8 Bolts	2	HDW422	7/16" Lock Washers
6	HDW321	3/8" Lock Washers	2	HDW402	7/16" Lock Nuts
2	HDW969	7/16" - 14 x 5" Grade 8 Bolts	2	4217	Mount Pads (9906 Only)

INSTALLATION INSTRUCTIONS

These engine mounts are designed to bolt over the original S10 rubber motor mount pads or for best results and fit use Trans-Dapt Performance Heavy Duty motor mount pads Part No. 4217. When used with TH350 Trans. or the original T4/T5 Trans. driveshaft modifications will not be required. The engine mounts work best if first installing the welded mounts over the rubber motor mount pads. Install the grade 8 bolts through the rubber into the Trans-Dapt bracket. Once the mounts are in position, the engine then can be positioned onto the chassis for final assembly.

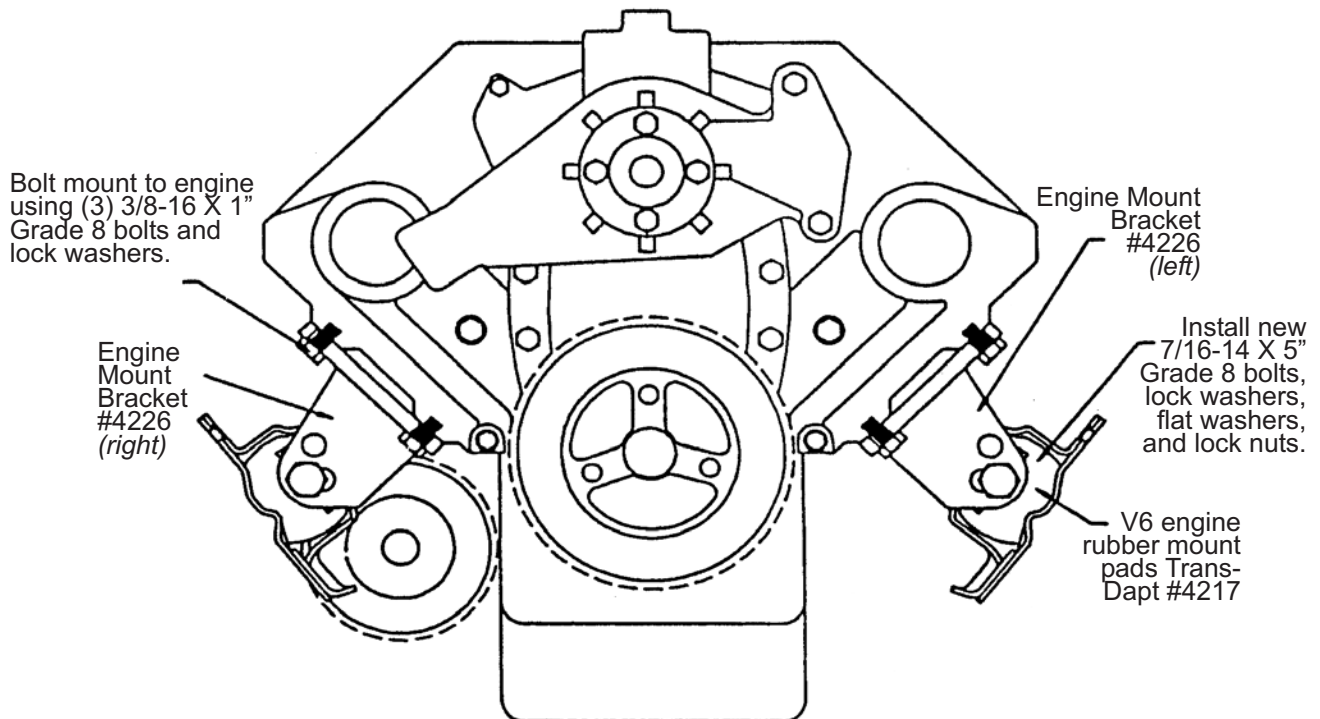

IMPORTANT GUIDELINES FOR A SAFE INSTALLATION

- Use **Only** the **Grade 8 bolts** and hardware provided in this motor mount kit.
- Use thread lock on all bolts that do not use a nylon-locking nut.
- Do not attempt to stack washers or shim the engine mounts to raise the engine.

SEE OTHER SIDE FOR SAE STANDARDS FOR STEEL BOLTS.

BOLT GRADES & TORQUING INFORMATION

SAE STANDARDS FOR STEEL BOLTS

The SAE has established a sequence of grades from 0 to 8 for steel bolts, on the basis of the metal from which the bolt is made and the manner of manufacture. Available grades run from 2 to 8, with 8 the strongest. Higher-grade numbers almost always mean increased strength (an exception is that some grade 6 bolts are stronger than grade 7). The heads of steel bolts are marked to identify their grade.

IDENTIFYING BOLT GRADE

All Grading on Hex Head steel bolts can easily be identified. Grading is identified by the number of lines on the head of each bolt (Please refer to the illustrations below).

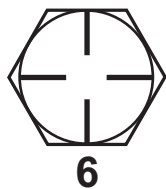
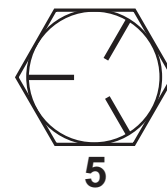
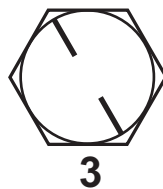
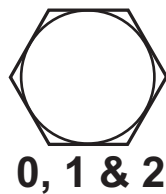

TORQUING BOLTS

As a rule, when a bolt is installed, the nut (over a washer) should be turned and not the bolt's head. Unless a torque wrench is used the tendency is to undertighten large bolts and overtighten small ones. Suggested torques are given below. These suggestions do not apply if the bolt or nut has been specially lubricated.

**Bolts should not be Installed or Torqued more then one time.
Replace any used bolts with the exact same size and grade.**

Approximate Torque Settings for Cadmium-plated Bolts, specially lubricated, in foot-pounds.

BOLT DIAMETER IN INCHES										
BOLT GRADE	1/4"	5/16"	3/8"	7/16"	1/2"	9/16"	5/8"	3/4"	7/8"	1"
SAE 2	4.6	9	15	24	36	50	69	117	184	273
SAE 3	6.9	14	24	38	57	82	113	198	317	477
SAE 5	7.5	15	25	40	59	83	114	196	309	459
SAE 6, SAE 7	9.7	19	34	55	83	120	166	291	469	710
SAE 8	10.5	21	37	60	90	130	180	316	509	769
SOCKET HEAD CAP SCREWS	12.7	25	45	72	109	157	217	381	615	929