



TRAILFX

Recovery Winch

Owner's Manual

Key Winch Components

(W08B, W10B & W12B)

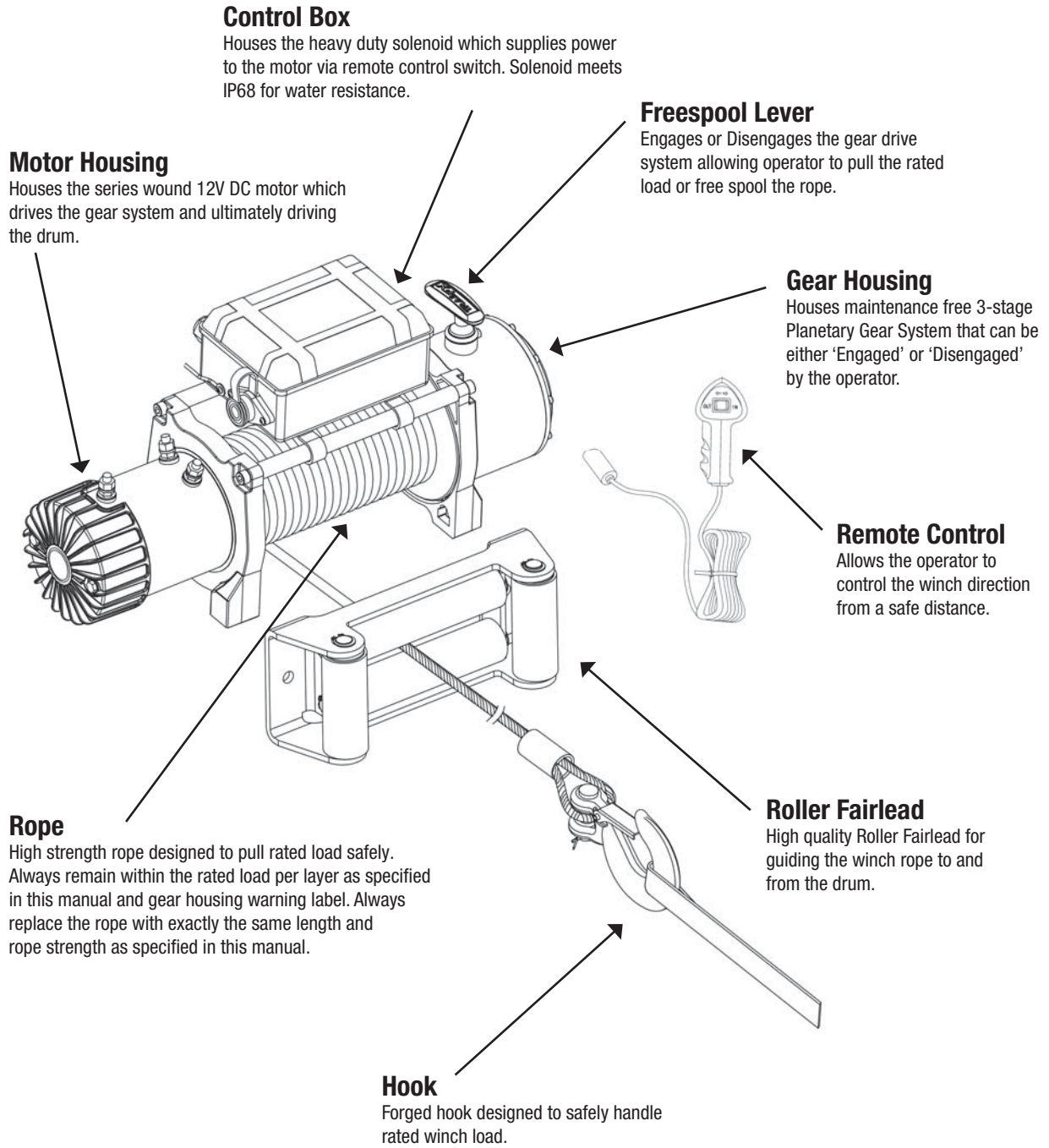

Key Winch Components

(WS10B)

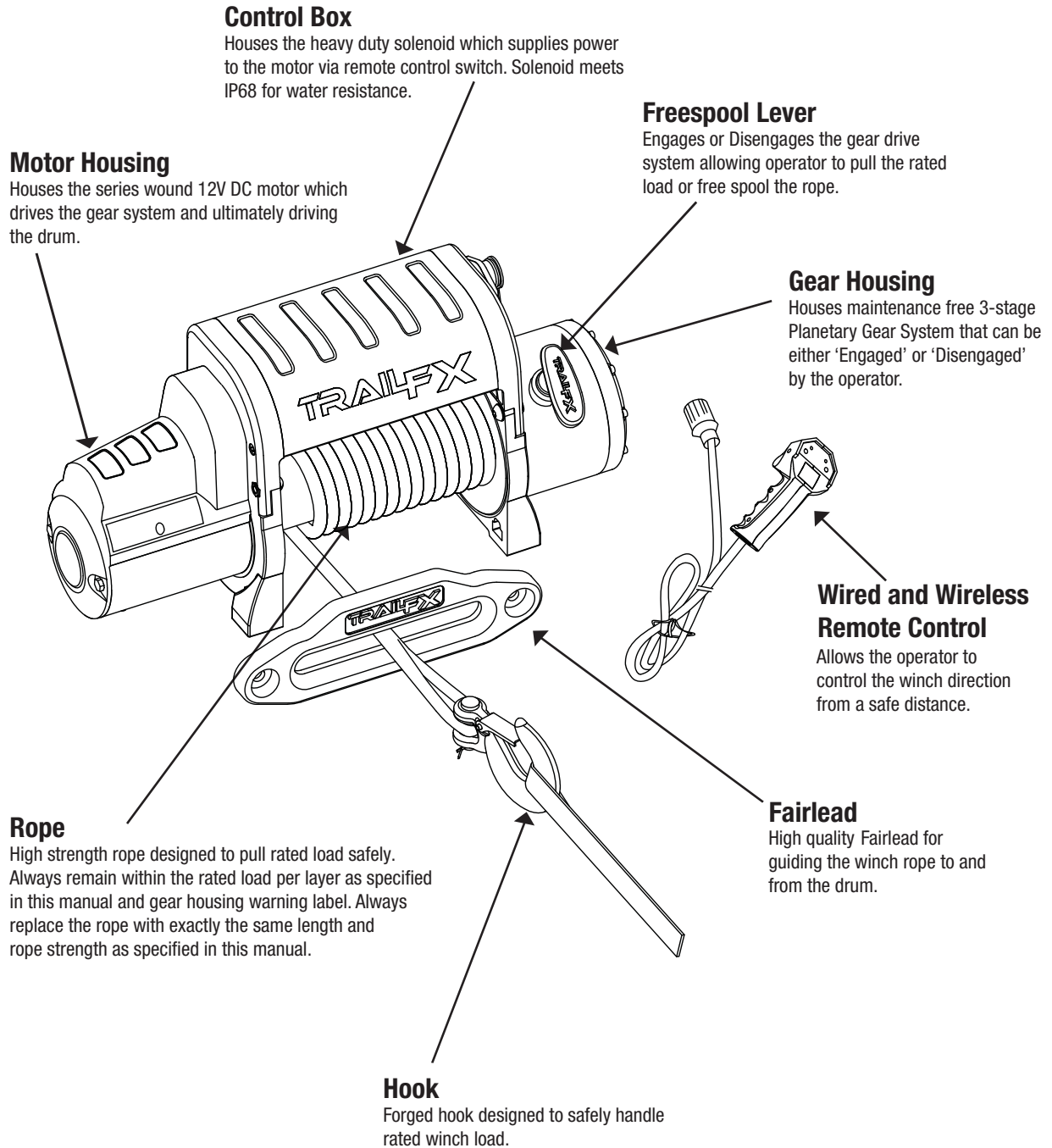

Safety Precautions



Observe safety precautions for personal safety and the safety of others.

Improper equipment operation may cause personal injury and equipment damage.

Never operate this winch if you are under 16 years of age.

Never operate this winch when under the influence of drugs, alcohol or medication.

Read the following carefully before attempting to operate your winch and keep the instructions for future reference.

1. **Dress properly:**

- Don't wear loose clothing or jewelry. They can be caught in moving parts.
- Wear proper winching gloves when handling winch rope. Do not handle rope with bare hands as broken strands can cause injuries.
- Non-skid footwear is recommended.

2. **Keep a safe distance:**

- Ensure that all persons stand well clear of winch rope and load during winch operation, 1.5 times of the rope length is recommended. If a rope pulls loose or breaks under load, it can lash back and cause serious personal injury or death.
- Don't step over the rope.
- All visitors and onlookers should be kept away from the work area.
- Keep proper footing and balance at all times.

3. **Don't abuse the electrical cables:**

- Never carry your winch by the electrical cables or yank it to disconnect it from the receptacle.
- Keep electrical cables from heat, oil and sharp edges.

4. **Don't overwork the winch:**

- If the motor becomes uncomfortably hot to touch, stop and let it cool for a few minutes.
- Shut off power to the winch if the motor stalls.



Don't exceed maximum line pull ratings shown in tables.

Shock loads must not exceed these ratings

5. **Avoid unintentional starting:**

- Winch clutch should be disengaged when not in use and fully engaged when in use.

6. **Check damaged parts:**

- Before using, you should check your winch carefully. Any part that is damaged should be properly repaired or replaced. Technical support and replacement parts may be obtained by contacting customer service as specified on the back cover of the manual or on the warranty card.

7. **Repair your winch:**

- When repairing, use only identical replacement parts or it may cause considerable danger to the user. Replacement parts may be obtained from customer service as specified on the back cover of the manual or on the warranty card.

8. **Re-spool the rope:**

- Winching gloves must be worn while re-spooling. It is necessary to maintain slight load on the rope. Hold the rope with one hand and the remote control switch with the other. Start as far back and in the center as you can. Walk up keeping load on the rope as the winch is powered in.
- Do not allow the rope to slip through your hand and do not approach the winch too closely.
- Turn off the winch and repeat the procedure until all the rope is spooled except 3 ft.
- Disconnect the remote control switch and finish spooling in rope by rotating the drum by hand with clutch disengaged.
- On hidden winches, spool in rope under power but keep hands clear.

Winch Operation Warnings

Read the following carefully before attempting to operate your winch and keep the instructions for future reference.

1. The uneven spooling of rope, while pulling a load, is not a problem, unless there is rope stacked up on one end of the drum. If this happens reverse the winch to relieve the load and move your anchor point further to the center of the vehicle. Once complete, you can unspool and rewind for a more balanced lay of the rope.
2. Store the remote control switch inside your vehicle where it will not get damaged. Inspect it before you plug in.
3. When ready to begin spooling in, plug in remote control switch with clutch disengaged. Do not engage clutch with motor running.
4. Never connect the hook back to the rope as this causes rope damage. Always use a sling or chain of suitable strength.
5. Observe your winch while winching if possible, while standing at a safe distance. Stop the winching process every meter or so to assure the rope is not pulling up in one corner. Jamming the rope can break your winch.
6. Do not attach tow hook to winch mounting plate. It must be attached to vehicle frame.
7. The use of a snatch block will aid recovery operations by doubling the winch capacity, halving the winching speed and helps to maintain direct line pull to the centre of the rollers. While double loading, the winch hook should be attached to the chassis of the vehicle.
8. Ensure rated "D" or bow shackles are used in conjunction with an approved tree trunk protector to provide a safe anchor point.
9. When extending winch rope, ensure that at least eight wraps of rope remain on drum at all times. Failure to do this could result in the rope parting from the drum under load. Serious personal injury or property damage may result.



10. All winches are provided with a red marking on the rope which identifies where (8) rope wraps remain on the winch drum. No recovery should be attempted beyond this marking or serious injury may occur.

11. Since the maximum line pull is achieved on the first layer of the winch, it is desirable to pull off as much line as you can for heavy pulls. Doubling or tripling using snatch blocks can help. You must leave at least eight wraps minimum on the drum or see no red rope exposed!
12. Draping a heavy blanket or similar object over the extended winch rope is recommended as it will dampen any back lash should a failure occur.
13. Neat, tight spooling avoids rope binding, which is caused when a load is applied and the rope is pinched between the others. If this happens, alternatively power the winch in and out. Do not attempt to work a bound rope under load, free by hand.
14. Apply blocks to wheels when vehicles are on an incline.
15. Battery:
 - Be sure that the battery is in good condition.
 - Avoid contact with battery acid or other contaminants.
 - Always wear eye protection when working around a battery.
 - Have the engine running when using the winch, to avoid rapid degradation of the battery.

Winch Operation Warnings Continued

16. Winch rope:

- Be sure that the rope is in good condition and is attached properly.
- Do not use the winch if rope is frayed.
- Do not move the vehicle to pull a load.
- Do not replace the rope with a rope of lesser strength.
- The life of the rope is directly related to the use and care it receives. Following its first and subsequent uses, a rope must be wound onto the drum under a load of at least 500lbs (230kgs) or the outer wraps will draw into the inner wraps and severely damage the rope during the winching. The first winch use should be a familiarization run while in a relaxed, non-recovery situation. Spool out the rope until the red rope mark appears (about 8 wraps remaining on the drum), and then rewind the rope on the drum under a load of 500lbs (230kgs) or more.
- When the rope is replaced, be sure to apply a thread locking compound to the rope clamp thread. Tighten the clamp screw properly but do not over tighten. The thread locking compound will prevent loosening of the screw in arduous conditions.



17. Do not attempt to exceed the pulling limits of the winch.

18. Do not drive your vehicle to assist the winch in any way. Vehicle movement in combination with winch operation may overload the rope, the winch itself or cause damaging shock loads!

19. Shock loads when winching are dangerous! A shock load occurs when an increase force is suddenly applied to the rope. A vehicle rolling back on a slack rope may induce a damaging shock load.

20. The winches shown in this manual are solely for vehicle and non-industrial applications.

21. Do not use winch in hoisting applications due to required hoist safety factors and features.

22. Do not use the winch to lift, support or otherwise transport personnel.

Installation

Mounting your Winch

1. The winch is to be mounted into a suitable sized mounting frame using the 4 point foot mounting system in either a horizontal or vertical plane.
 - It's very important that the winch be mounted on a flat surface so that the three sections (motor, rope drum and gear housing) are properly aligned.
 - The fitment of winches and/or a frontal protection system may affect the triggering of SRS air bags. Check that the mounting system has been tested and approved for winch fitment in the air bag equipped vehicle.
 - Always verify area is clear of fuel lines, fuel tank, brake lines, electrical wires, etc. when drilling.
2. Winch mounting frames and/or frontal protection systems are suggested to suit most popular vehicle. Winch frames are packaged with detailed fitting instructions.
3. The winch should be secured to the mounting with the hardware included with your winch.
4. The fairlead is to be mounted so as to guide the rope onto the drum evenly.

W08B, W10B

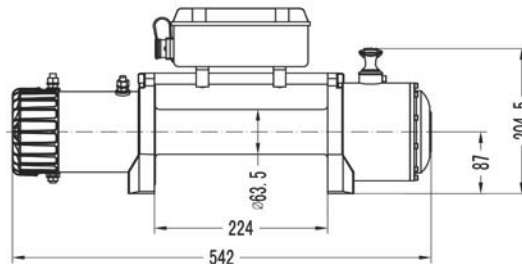
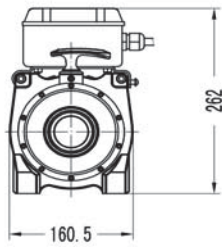
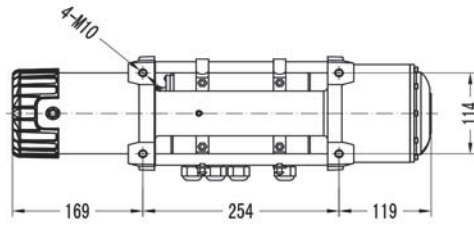
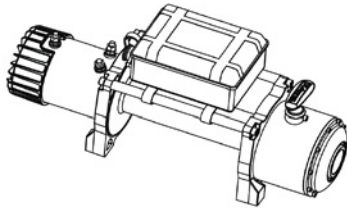

W12B

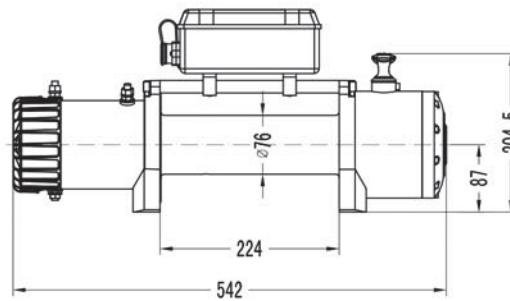
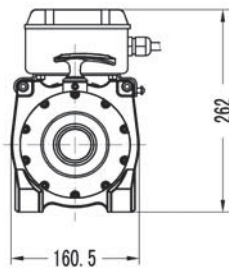
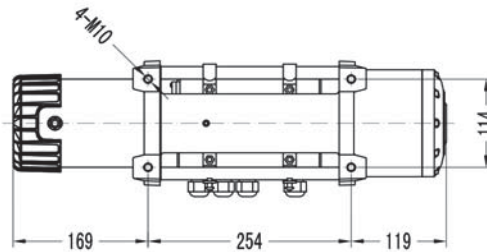
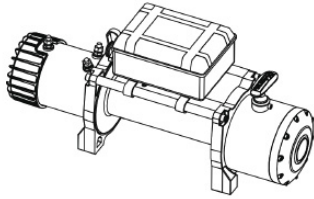

WS10B

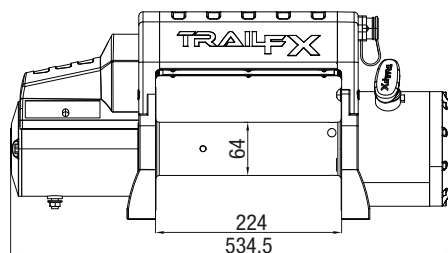
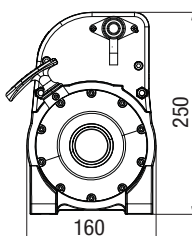
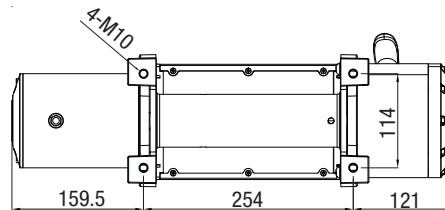
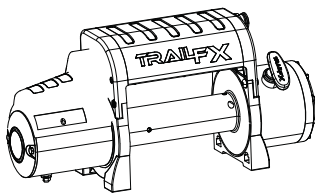

All dimensions are in mm.

Electrical connection

For normal self-recovery work, your existing electrical system is adequate. A fully charged battery and proper connections are essential. Run the vehicle engine during winching operation to keep battery charged.

Pay close attention to proper electrical cable connection as follows:

W08B, W10B, and W12B

1. Short red cable (B') connecting to the red terminal (B) of the motor.
2. Short black cable with yellow jacket (C') connecting to the yellow terminal (C) of the motor.
3. Short black cable with black jacket (D') connecting to the black terminal (D) of the motor.
4. Thin black cable (A') connecting to bottom terminal (A) of the motor.
5. Long black cable (1.8m), one terminal (A') connecting to the bottom terminal (A) of the motor and the other terminal negative (-) connecting to the negative (-) terminal of battery.
6. Long red cable positive (+) connecting to positive (+) terminal of battery.

WS10B

1. Short red cable from Winch connecting to the Positive (+) terminal of the battery.
2. Short black cable (supplied separately with the Winch) one end connecting to the Winch Terminal A & the other to the Negative (-) terminal of the battery

Remote control operation (for WS10B):

1. Plug the control cable (with the remote hand controller attached) into the socket on the control box and turn slightly counter-clockwise to lock into position.
2. It is recommended that for the initial set-up of the winch (prior to applying any load) that the winch be operated in the Wired mode.
3. Once the winch has been set-up then the remote hand control can be operated either in the Wired or Wireless mode.
4. To use the remote hand controller in the Wireless mode unplug the remote hand controller from the control cable.
5. The hand control is not waterproof and care must be taken in its usage.

Remote battery changing instructions:

1. Remove the screws & dismantle remote cover.
2. Remove the CR2 3V 900 mAh battery (Blue Color) & replace with a new one. This battery is not related to the remote operation & needs to be changed only when the LED light is not working.
3. For changing remote operation battery, remove the "In & Out Switch" from PCBA by pulling it upwards.
4. Slightly bend the small PCBA located above A23 12V battery (Golden Color) for easy access and replace with a new one.
5. Bend the same PCBA back to its original position & fix "In & Out Switch".
6. Fix the remote cover back in to its position & assemble with the screws.
7. Please use only the designated size batteries mentioned above.

Note

1. Your battery must be kept in good condition.
2. Be sure battery cables are not drawn tight across any surfaces, which could possibly damage them.
3. Corrosion on electrical connections will reduce performance or may cause a short.
4. Clean all connections especially in remote control switch and receptacle.
5. In salty environments use a silicone sealer to protect from corrosion.
6. Index the heads of the plate studs into the keyhole slots on the back of the winch.



If electrical cables are closer to hot surface, use the heat protection sleeve as required to prevent damage.

W08B, W10B & W12B

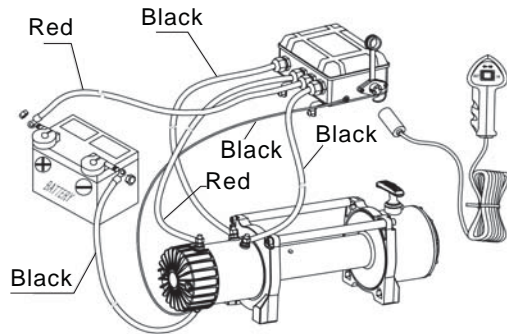
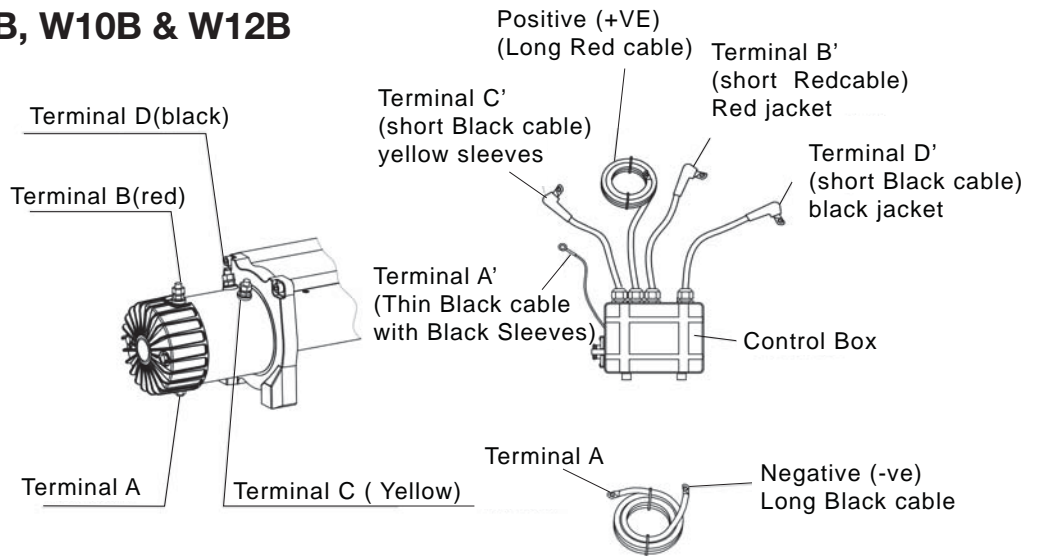

WS10B

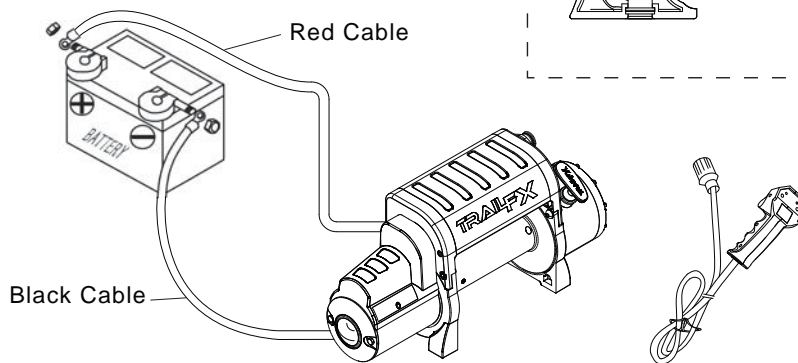
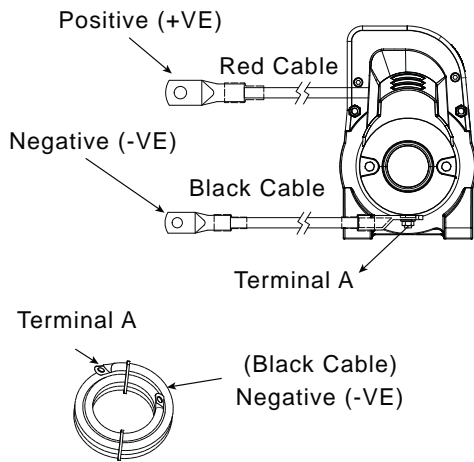

Wireless Remote battery changing instruction

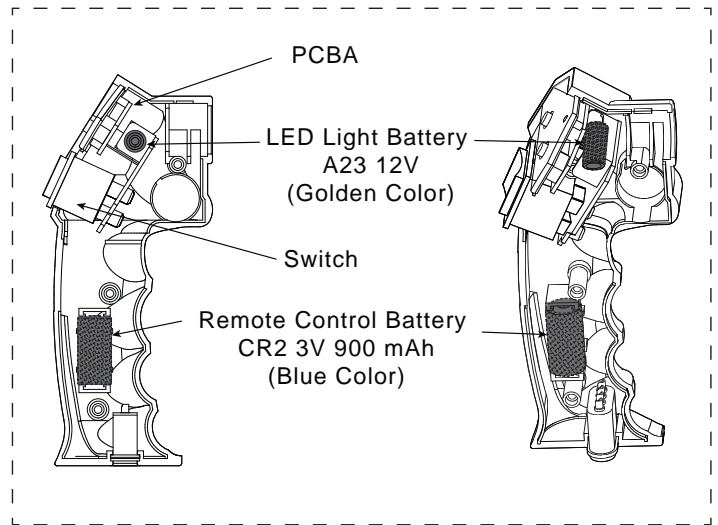

Winch Operation

Suggestion

The best way to get acquainted with how your winch operates is to make a few test runs before you actually need to use it. Plan your test in advance. Remember you can hear your winch as well as you can see it operate. Get to recognize the sound of a light steady pull, a heavy pull, and sounds caused by load jerking or shifting. Soon you will gain confidence in operating your winch and its use will become second nature to you.

Operating

1. Ensure the vehicle is secure by applying the parking brake or chocking the wheels.
2. Pull out the rope to the desired length and connect to an anchor point.
The winch clutch allows rapid uncoiling of the rope for hooking onto the load or anchor point. The shifter tab located on the gear housing of the winch operates the clutch as follows:
 - a) To disengage the clutch, move the clutch shifter tab into the "OUT or FREE" position. Rope may now be free spooled off the drum.
 - b) To engage the clutch, move the clutch shifter tab into the "IN or LOCKED" position. The winch is now ready for pulling.
3. Recheck all rope rigging before proceeding.
4. Plug in the winch remote control. It is recommended that the winching operation takes place from the driver's position to ensure safe operation.
5. To commence winching operation, start vehicle engine, select neutral in transmission, maintain engine speed at idle.
6. Operate the remote control switch to IN or OUT until the vehicle has been retrieved. Regularly check the winch to ensure rope is winding onto the drum evenly.



MUST READ THIS



1. Never winch with your vehicle in gear which would damage your vehicle's transmission.
2. Never wrap the rope around the object and hook onto the rope itself. This can cause damage to the object being pulled, and kink or fray the rope.
3. Keep hands, clothing, hair and jewelry clear of the drum area and rope when winching.
4. Never use the winch if the rope is frayed, kinked or damaged.
5. Never allow anyone to stand near the rope or in line with the rope behind the winch while it is under power. If the rope should slip or break, it can suddenly whip back towards the winch, causing a hazard for anyone in the area. Always stand safely to the side while winding.
6. Do not leave the remote control plugged in when not in use.



CHECK THE WINCH CAREFULLY AND THOROUGHLY BEFORE OPERATING!

Maintenance

It is highly recommended that the winch be used regularly (once a month). Simply power the rope out 50 ft., free spool 15 ft. and then power back in. This will keep all components in good working condition so that the winch can be relied on when needed. Contact your authorized outlet for technical assistance and repairs.

Trouble Shooting		
Symptom	Possible Cause	Suggested Remedy
Motor does not turn on	Switch Assembly not connected properly. Drained Remote Battery (in case of wireless Remote).	Insert switch Assembly firmly to the connector. Replace Batteries as per the instructions in page no. 9.
	Loose battery cable.	Tighten nuts on cable connectors.
	Solenoid malfunctioning.	Tap solenoid to free contact, applying 12 volts to coil terminal directly. Make an audible clicking when activating.
	Defective switch Assembly.	Replace switch Assembly.
	Defective motor.	Check for voltage at armature port with switch pressed. If voltage is present, replace motor.
	Water has entered motor.	Drain and dry, Run in short bursts without load until completely dry.
Motor runs too hot.	Long period of operation.	Let winch cool down periodically.
Motor runs slowly or without normal power.	Battery runs down.	Recharge battery by running vehicle.
	Insufficient current or voltage.	Clean, tighten or replace the connector.
Motor runs but rope drum does not turn.	Clutch not engaged.	Turn clutch into IN position, if that does not work, ask a qualified technician to check and repair.
Motor runs in one direction only.	Defective or stuck solenoid.	Tap solenoid to free contacts. Repair or replace solenoid.
	Defective switch Assembly.	Replace switch Assembly.

Lubrication

All moving parts in the winch are permanently lubricated with high temperature lithium grease at the time of assembly. Lubricate wire rope periodically using light penetrating oil. Inspect for broken strands and replace if necessary. If the rope becomes worn or damaged it must be replaced.

Rope Installation

Unwind the new rope by rolling it along the ground, to prevent kinking. Remove old rope and observe the manner in which it is attached to the rope drum flange. Install new rope in the same way as the old rope is attached to the rope drum flange.



Replace rope with the exact diameter, length and strength as that of the existing rope.

TrailFX Winch Specifications				
TrailFX Part No.	W08B	W10B	W12B	WS10B
Rated Line Pull	8,000 Lbs., (3600 kgs.) single-line	10,000 Lbs., (4532 kgs.) single-line	12,000 Lbs., (5440 kgs.) single-line	10,000 Lbs., (4532 kgs.) single-line
Motor	6.7 HP/12 V, series wound	6.5 HP/12 V, series wound	6.5 HP/12 V, series wound	6.5HP/12 V series wound
Remote Control	Remote Switch, 12' (3.7m) lead	Remote Switch, 12' (3.7m) lead	Remote Switch, 12' (3.7m) lead	Wired/Wireless Remote Switch with LED, 12' (3.7m) lead
Electrical Control	450 A Heavy Duty Solenoid	450 A Heavy Duty Solenoid	450 A Heavy Duty Solenoid	450 A Heavy Duty Solenoid
Gear Train	3 Stage Planetary	3 Stage Planetary	3 Stage Planetary	3 Stage Planetary
Gear Ratio	150:1	218:1	265:1	218 : 1
Clutch Type	Rotating Ring Gear	Rotating Ring Gear	Rotating Ring Gear	Rotating Ring Gear
Braking Action	Automatic In-the-Drum	Automatic In-the-Drum	Automatic In-the-Drum	Automatic out of Drum
Drum Size (Diameter X Length)	2.5" X 8.82"	2.5" X 8.82"	3.0" X 8.82"	2.5" X 8.82"
Rope (Diameter X Length)	8.1 mm X 94' Steel Rope	9.1 mm X 94' Steel Rope	9.5 mm X 94' Steel Rope	* 9.5 mm X 94' Grey Synthetic Rope*
Fairlead	4 Way Roller	4 Way Roller	4 Way Roller	Aluminum Fairlead
Recommended Battery	650 CCA minimum for Winching	650 CCA minimum for Winching	650 CCA minimum for Winching	650 CCA minimum for Winching
Battery Lead	25 mm ² , 72" (1.8 m)	25 mm ² , 72" (1.8 m)	25 mm ² , 72" (1.8 m)	25 mm ² , 72" (1.8 m)
Weight	88 lbs.	93 lbs.	97 lbs.	79 lbs
Mounting Pattern	10" x 4.5"	10" x 4.5"	10" x 4.5"	10" x 4.5"

Winch Performance (12V DC)								
<i>Performance specs are based on first layer of drum.</i>								
Line Pull (lbs)	Line Speed Ft / min	Motor Current Amps	Line Speed Ft / min	Motor Current Amps	Line Speed Ft / min	Motor Current Amps	Line Speed Ft / min	Motor Current Amps
0	40	80	30	75	24	80	30	75
2000	18	170	14	140	12.5	150	14	140
4000	11	250	11	210	10	200	11	210
6000	8	330	8	260	8	260	8	260
8000	6	390	6	310	6.5	315	6	310
10000			4	370	5	365	4	370
12000					4	410		

Line Pull (Layer)	Line Pull by Layer (lbs)	Rope Capacity (Ft)	Line Pull by Layer (lbs)	Rope Capacity (Ft)	Line Pull by Layer (lbs)	Rope Capacity (Ft)	Line Pull by Layer (lbs)	Rope Capacity (Ft)
1	8000	16	10000	16	12000	16	10000	16
2	6500	42	8100	42	9800	42	8100	42
3	5500	72	6900	72	8300	72	6900	72
4	4500	94	6000	94	7200	94	6000	94

Motor rating based on input power.

Solenoid meets IP68 specification for water resistance.

*Synthetic rope made of Dyneema SK75 fibre.

Parts List W08B and W10B

8000lb and 10000lb

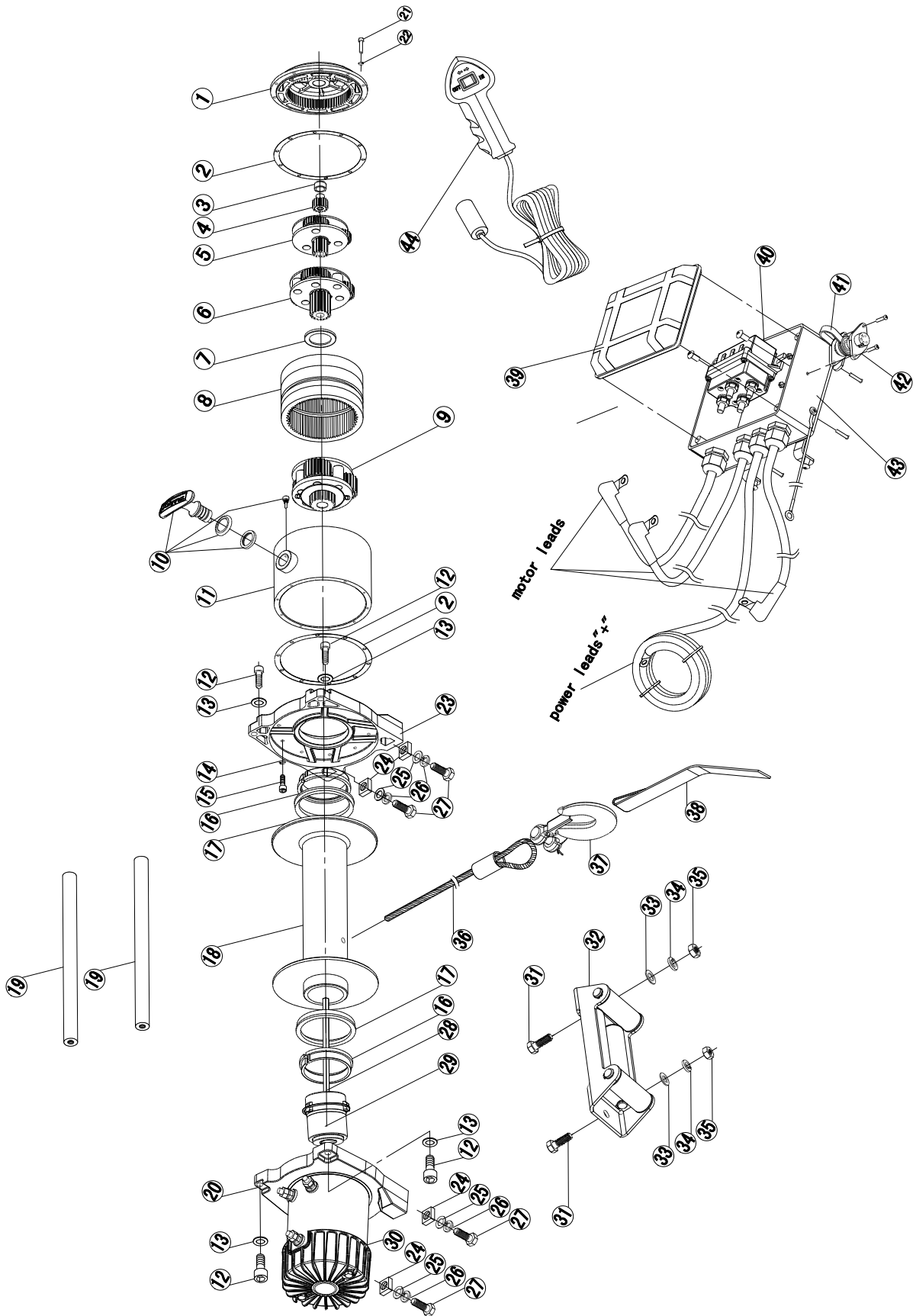

Parts List W12B

12000lb

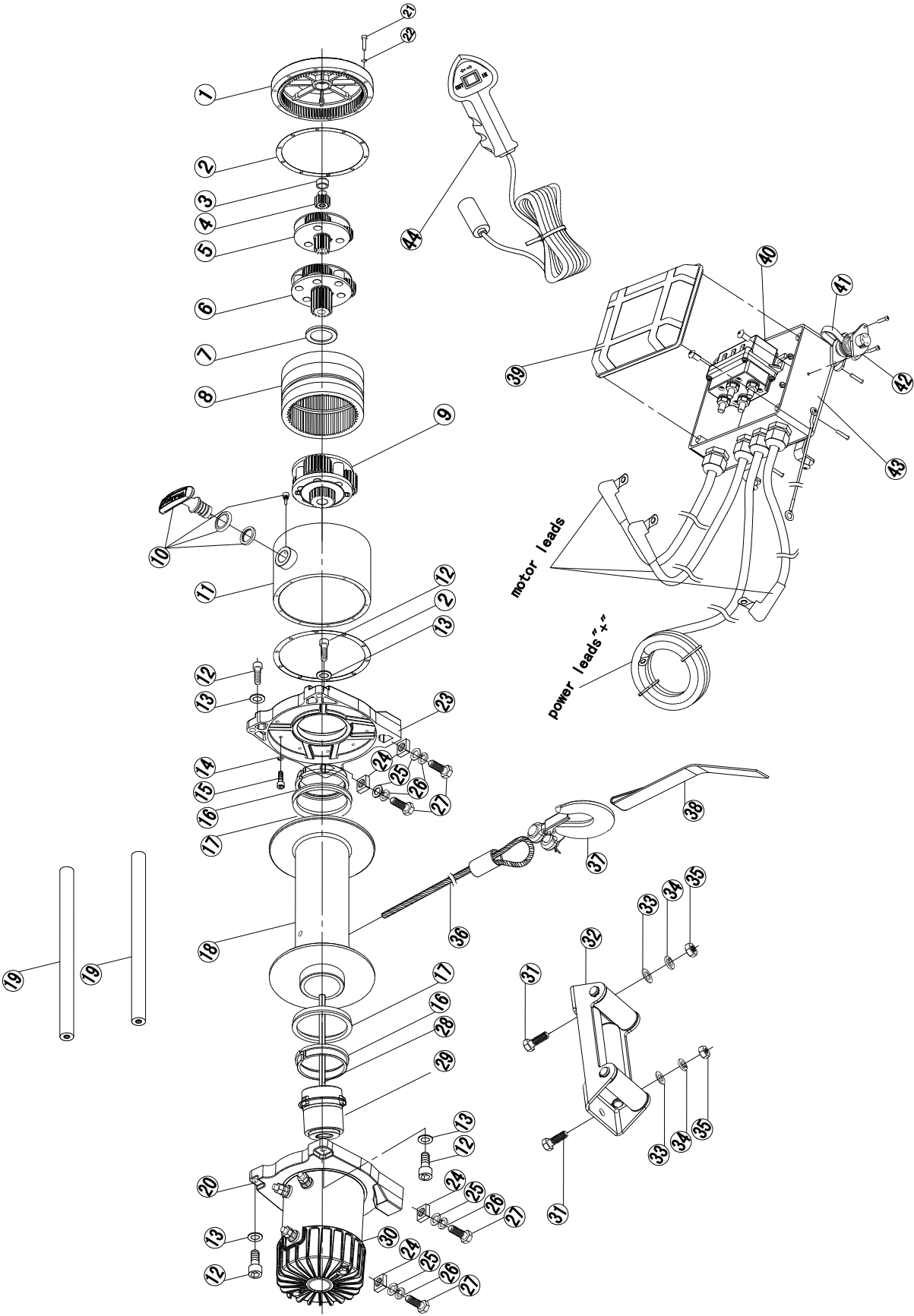

Parts List WS10B

10000lb

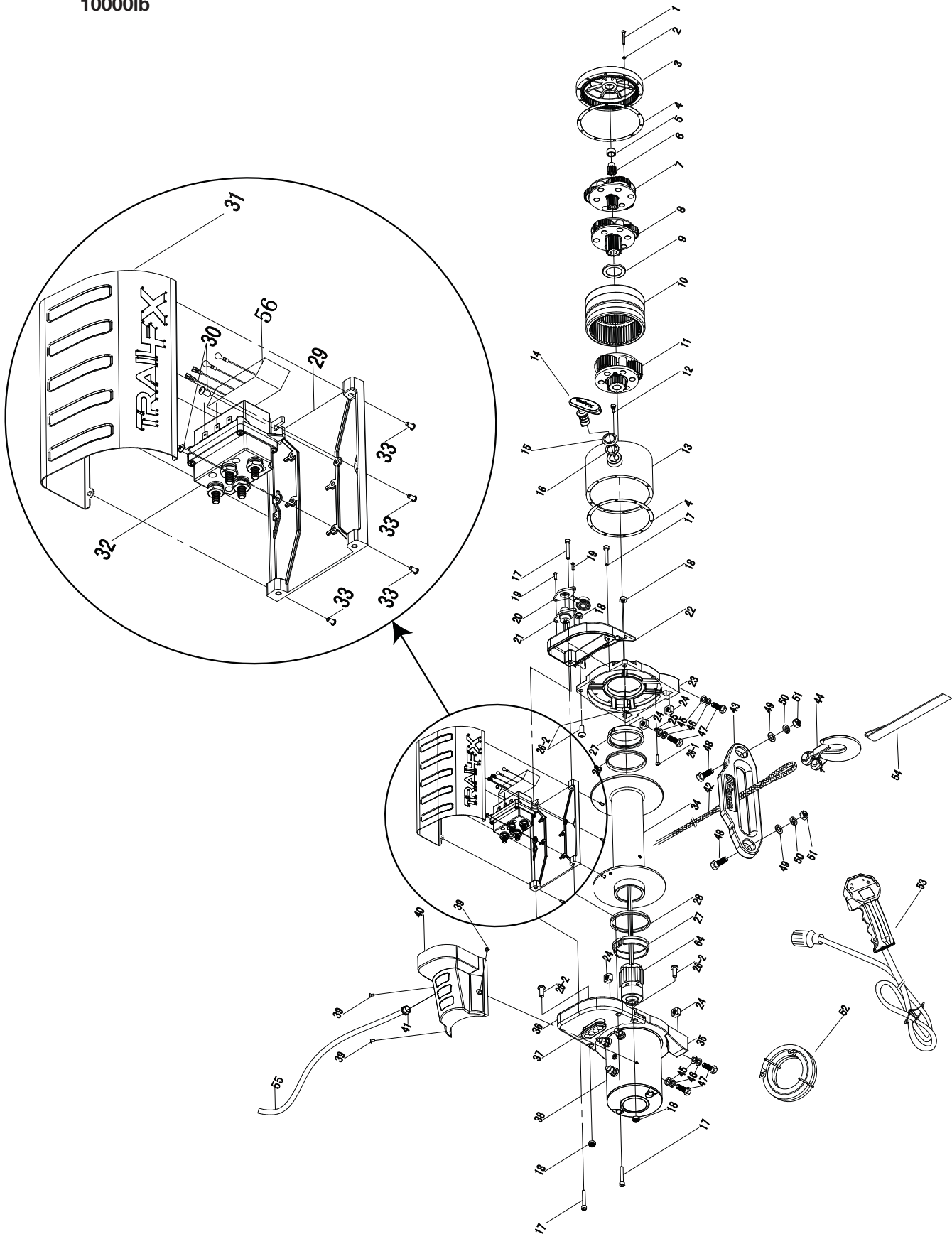

Part List - W08B, W10B & W12B

No.	Description	Qty
1	Gear Box End Cap	1
2	Washer	2
3	Oil-retaining Bearing	1
4	Allen Center Wheel	1
5	Stage-1 of Planetary Wheel	1
6	Stage-2 of Planetary Wheel	1
7	Washer	1
8	Inner Gear	1
9	Stage-3 of Planetary Wheel	1
10	Clutch Set	1
11	Gear Box Tube	1
12	Hexagon Socket Head Cap Screw	4
13	Gasket	4
14	Spring Washer	10
15	Hexagon Socket Head Cap Screw	10
16	Sliding Bearing	2
17	Seal Ring	2
18	Drum Assembly	1
19	Tie Bar	2
20	Motor Base	1
21	Hexagon Socket Head Cap Screw	10
22	Spring Washer	10
23	Gear Box Base	1
24	Square Nut	4
25	Flat Washer	4
26	Spring Washer	4
27	Hexagon Socket Head Cap Screw	4
28	Drive Shaft	1
29	Brake Assembly	1
30	Motor	1
31	Hexagon Bolt	2
32	Roller Fairlead	1
33	Flat Washer	2
34	Spring Washer	2
35	Nut	2
36	Rope Assembly	1
37	3/8 Hook	1
38	Hand Saver Strap	1
39	Control Box Top Cover	1
40	Solenoid	1
41	Water Proof Cover	1
42	Socket	1
43	Control Box Bottom Cover	1
44	Remote Control Switch	1

Replacement Parts list













Part No.	Description	W08B	W10B	W12B	WS10B
WA001	Control Box	☆	☆	☆	
WA002	Remote Control	☆	☆	☆	
WA003	Motor	☆			
WA004	Motor		☆	☆	
WA005	Wire Rope	☆			
WA006	Wire Rope		☆		
WA007	Wire Rope			☆	
WA008	Fairlead	☆	☆	☆	
WA009	Hook	☆	☆	☆	☆
WA010	Hook Strap	☆	☆	☆	☆
WA011	Battery Cable	☆	☆	☆	☆
WA012	Mounting HW	☆	☆	☆	☆
WA020	Remote Control				☆
WA021	Motor Assembly				☆
WA022	Synthetic rope				☆
WA023	Aluminium Fairlead				☆
WA024	Solenoid				☆

☆ - Applicable

Part List - WS10B

No.	Description	Qty
1	Hexagon socket head cap screw	10
2	Lock washer	10
3	Gearbox end cap	1
4	Washer	1
5	Oil-retaining gearing	1
6	Sun gear	1
7	1st stage planetary gear	1
8	2nd stage planetary gear	1
9	Washer	1
10	Clutch gear	1
11	3rd stage planetary gear	1
12	Spacing bolt	1
13	Gearbox housing	1
14	Clutch knob	1
15	Clutch knob base	1
16	Clutch knob washer	1
17	Hexagon socket head cap screw	4
18	Locknut M8	4
19	Cross recessed countersunk head screw	2
20	Socket cover	1
21	Socket	1
22	Control box bracket (right)	1
23	Gearbox bracket	1
24	Nut	4
25	Lock washer	10
26-1	Hexagon socket head cap screw	10
26-2	Hexagon socket head cap screw	4
27	Sliding bearing	2
28	Seal	2
29	Control box base	1
30	Cross recessed countersunk head screw	2
31	Control box cover	1
32	Solenoid	1
33	Cross recessed countersunk head screw	6
34	Drum	1
35	Motor bracket	1
36	Control box bracket (left)	1
37	Power cable hole seal	1
38	Motor Assy	1
39	Cross recessed countersunk head screw	3
40	Motor cover	1
41	Power cable hole seal	1
42	Synthetic rope Assy	1
43	Fairlead	1
44	3/8 Hook	1
45	Flat washer	4
46	Lock washer	4
47	Hex head cap screw	4
48	Hex head cap screw	2
49	Flat washer	2
50	Lock washer	2
51	Nut	2
52	Black power cable (-)	1
53	Remote switch	1
54	Hand saver strap	1
55	Red power cable	1
56	Receiver	1

Winch Accessories List





Product No / Description	Product Images		Product Features
<p>WA014 TFX Accessory Kit-Medium</p>	 		<ul style="list-style-type: none"> • Winch Rigging Kit with 2 X 8 Inch, 17,600 lbs Breaking Strength Tree Trunk Protector • 17,600 lbs Capacity Zinc Plated Snatch Block with Grease Port • Two 3/4" 10,000 lbs Rated D-Shackles. • Pair of Orange Gloves • 10' X 5/16" 17,600 lbs Rated Grade 70 Recovery Choker Chain With Hooks • 2" X 30' 17,600 lbs Breaking Strength Recovery Strap • 16.5" X 10" X 12.5" Orange Denier Gear Bag with Black TrailFX Logo
<p>WA015 TFX Winch Gloves</p>	 		<ul style="list-style-type: none"> • Winch Gloves • Extra Large • Orange Color • Black TrailFX Logo
<p>WA016 TFX Winch Cover</p>	 		<ul style="list-style-type: none"> • Winch Cover • For TrailFX Winches W08B/ W10B/ W12B/WS10B • Orange with TrailFX Logo
<p>WA017 TFX Winch Mounting Plate - Universal</p>	 		<ul style="list-style-type: none"> • Winch Mount • For Light Duty Winches • Flat Fixed Mount • Textured Powder Coated • Black Color
<p>WA018 TFX Winch Mounting Plate - Cradle</p>	 		<ul style="list-style-type: none"> • Winch Mount • For Light Duty Winches • 2" Receiver Mount • Textured Powder Coated • Black Color
<p>WA019 TFX Winch Wireless Remote</p>	 		<ul style="list-style-type: none"> • Winch Remote Hand Held Controller • For TrailFX Winches W08B/W10B/W12B • Wireless

Gear Box Clocking Instructions for TrailFX Winches W08B, W10B & W12B

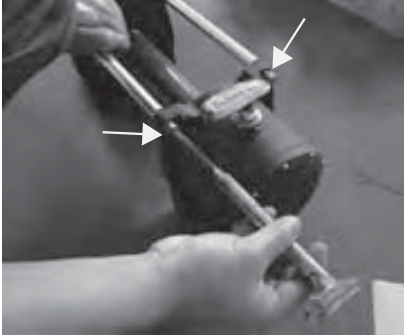

Modification of original design is not recommended and will void warranty

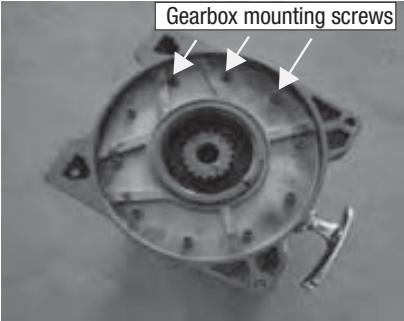

	<ul style="list-style-type: none">• Unscrew two Tie bar bolts.
	<ul style="list-style-type: none">• Separate the gear box from the drum.
	
	<ul style="list-style-type: none">• Unscrew 10 gearbox mounting screws using Allen key size 3.• Rotate the gearbox housing to the desired position.• Retighten all the gearbox housing mounting screws.• Reassemble the gearbox with the drum & tie bar.
	<p>10 position options possible with 36° angle increment.</p>