



# Running Board

## Part No. R0027MK



Fits: **2017**

**Toyota RAV4**

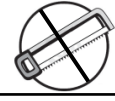

60-180 min

Cutting Not Required

Drilling Not Required



REMOVE CONTENTS FROM BOX. VERIFY ALL PARTS ARE PRESENT.



READ INSTRUCTIONS CAREFULLY BEFORE STARTING INSTALLATION.

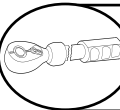

DO NOT OVER TORQUE. STANDARD OPERATING LOAD FOR TIGHTEN BODY MOUNT NUTS & BOLTS VARIES FROM **45** TO **65** FOOT POUND.



### PARTS LIST

Qty	Part Description	Qty	Part Description
1	Driver/left Side Running Board	2	10mm Rectangular Washers
1	Passenger/Right Side Running Board	10	10mm Plastic Retainers
1	Driver/Left Front Bracket	2	10-1.5mm x 40mm Hex Bolts
1	Passenger/Right Front Bracket	2	10-1.5mm x 30mm Hex Bolts
1	Driver/Left Front Support Bracket	6	10mm x 27mm OD x 3mm Large Flat Washers
1	Passenger/Right Front Support Bracket	8	10mm x 24mm OD x 2.2mm STD Flat Washers
1	Driver/Left Center Mounting Bracket	2	10-1.5mm Hex Nuts (Jam Nuts)
1	Passenger/Right Center Mounting Bracket	12	10-1.5mm Nylon Lock Nuts
1	Driver/Left Center Support Bracket	4	8-1.25mm x 30mm Hex Bolts
1	Passenger/Right Center Support Bracket	8	8mm x 16mm OD x 1.6mm Flat Washers
1	Driver/Left Rear Bracket	4	8-1.25mm Nylon Lock Nuts
1	Passenger/Right Rear Bracket	12	6-1.0mm x 20mm T-Bolts
2	Surface Reinforcement Plates	12	6mm x 22mm OD x 2mm Flat Washers
4	10mm x 50mm Bolt Plates	12	6mm Lock Washers
2	Locking Plates (for Bolt Plates)	12	6mm Hex Nuts
4	10mm x 35mm Bolt Plates	2	10-1.5mm x 40mm Carriage Bolts

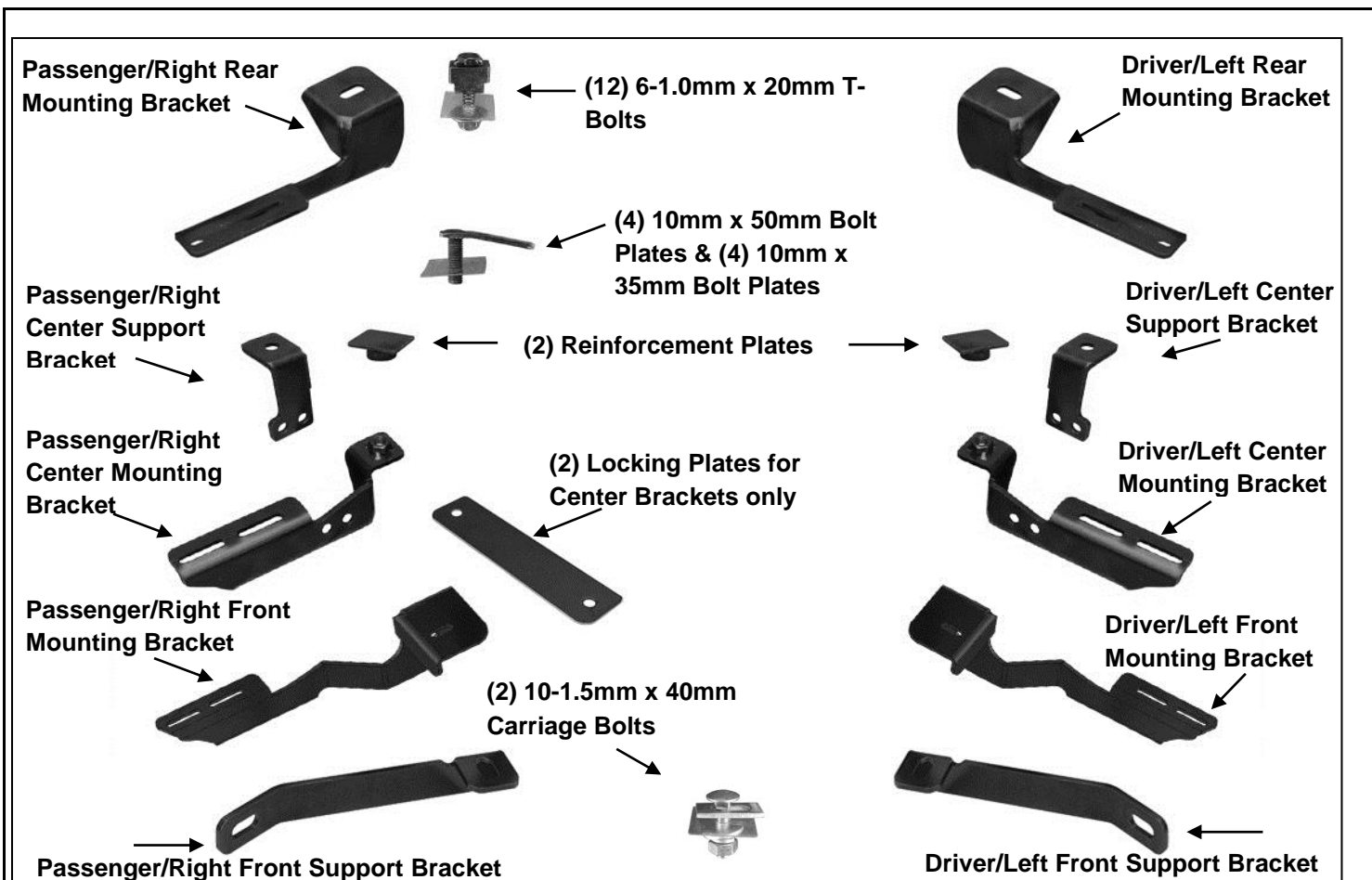

## INSTALLATION PROCEDURE

- Starting on the driver side of the vehicle, locate and remove the factory oval rubber plug and (2) round plugs in the bottom of the floor panel located closest to the front tire opening, **(Figure 1 & 2)**. Select (1) 10mm x 40mm Carriage Bolt, (1) 10mm Rectangular Washer and (1) 10mm Plastic Retainer, **(Figure 3A)**. Slide the Rectangular Washer onto and over the square shoulder on the Carriage Bolt. Thread the Retainer part way onto the Bolt. **NOTE:** The Plastic Retainer is designed to help hold the Bolt in place during Bracket installation. Insert the Carriage Bolt with Rectangular Washer and Retainer into the inner round hole in the floor panel. Line up the Carriage Bolt with the center of the hole and the Rectangular Washer across the hole. Pull the Carriage Bolt down through the slot in the Washer. Thread the Retainer down tight against the floor panel, **(Figure 3B)**.
- Select (1) 10mm x 35mm Bolt Plate and (1) 10mm Plastic Retainer, **(Figure 4A)**. Insert the Bolt Plate and thread the Plastic Retainer onto the Bolt Plate tight against the floor panel, **(Figure 4B)**.
- Next, select the driver side Front Bracket. Secure the Front Bracket to the Bolt Plate first with (1) 10mm x 27mm Large Flat Washer and (1) 10mm Nylon Lock Nut **(Figure 5)**. Snug but do not tighten.
- Select the driver side Front Support Bracket. Bolt the Support Bracket to the inner 10mm Carriage Bolt with (1) 10mm x 24mm STD Flat Washer and (1) 10mm Nylon Lock Nut, **(Figures 5)**. Leave hardware loose. Line up the slot in the Support Bracket with the slot in the Front Mounting Bracket. Bolt the Support Bracket to the front of the Mounting Bracket with (1) 10mm x 30mm Hex Bolt, (2) 10mm x 24mm STD Flat Washers and (1) 10mm Nylon Lock Nut **(Figure 5)**. Snug but do not tighten hardware.
- Move along the side of the vehicle to the center location below where the front and rear doors meet. Locate the 4th and 5th hole in the floor panel from the front wheel opening, **(Figure 6)**. Remove the (2) rubber plugs. Select (2) 10mm x 50mm Bolt Plates and (2) 10mm Plastic Retainers. Thread (1) Plastic Retainer part way onto each Bolt Plate, **(Figure 7A)**. Insert (1) Bolt Plate into the first and second round hole in the floor panel next to the pinch weld, **(Figure 7B)**.

**IMPORTANT:** Install the Bolt Plates with the "plates" pointing toward each other, **(Figure 7C)**. Thread the Retainer down tight against the panel.

- Slide (1) Lock Plate over the (2) 10mm x 50mm Bolt Plates. Attach the Lock Plate to the forward Bolt Plate with (1) 10mm x 27mm Large Flat Washer and (1) 10mm Nylon Lock Nut, **(Figure 8)**. Hang the Center Support Bracket from the rear Bolt Plate with (1) 10mm x 24mm STD Flat Washer and (1) 10mm Nylon Lock Nut, **(Figures 8—10)**. Do not tighten hardware at this time.

7. Select the Center Mounting Bracket, (1) 10mm x 40mm Hex Bolt, (1) 10mm Regular Hex Nut and (1) Reinforcement Plate, **(Figure 9)**. Thread the 10mm Hex Nut all the way down the 10mm x 40mm Hex Bolt. Insert the Hex Bolt with Nut up and into the welded nut on the tab on the Center Bracket, **(Figure 9)**.  
**NOTE:** Thread the Bolt in until a few threads are sticking out of the welded nut. **Do not** thread the Hex Bolt all of the way into the welded nut. Bolt the Center Mounting Bracket to the front side of the Center Support Bracket with (2) 8mm x 30mm Hex Bolts, (4) 8mm Flat Washers and (2) 8mm Nylon Lock Nuts, **(Figure 10)**. Leave hardware loose at this time.
8. Place (1) Reinforcement Plate onto the threaded end of the 10mm x 40mm Hex Bolt, **(Figure 9)**. Continue to thread the Hex Bolt in until the Reinforcement Plate is close to but not touching the bottom of the body panel, **(Figure 10)**. Snug but do not tighten the 8mm mounting hardware.  
**IMPORTANT:** Do not tighten the hardware on the Center Brackets until the final Steps, **(see Step 16)**.
9. Move along the vehicle to the rear mounting location, **(Figure 11)**. Remove the oval rubber plug. Select (1) 10mm x 35mm Bolt Plate and (1) 10mm Plastic Retainer, **(Figure 12A)**. Thread the Plastic Retainer onto the Bolt Plate and tight against the floor panel **(Figures 12B)**.
10. Select the driver side Rear Mounting Bracket. Hang the Rear Bracket from the T-Bolt with (1) 10mm x 27mm Large Flat Washer and (1) 10mm Nylon Lock Nut, **(Figure 13)**. Snug but do not tighten the 10mm Lock Nut on the rear Bracket.
11. Carefully un-wrap the driver side Running Board. From the front, slide (3) T-Bolts into each channel in the bottom of the Running Board, **(Figure 14)**. Slide the T-Bolts forward or back to line up with the slots in the (3) previously installed Mounting Brackets. Hold the Running Board up to the vehicle at a slight angle and gently push it into position against the rocker panel. Loosen Brackets if necessary to slide Running Board into place. Insert the T-Bolts through the slots in the Brackets, **(Figure 15)**.
12. Attach the Running Board to the (3) Mounting Brackets with the included (6) 6mm Flat Washers, (6) 6mm Lock Washers and (6) 6mm Hex Nuts, **(Figure 15)**. Do not tighten hardware at this time.
13. Check to see if the Running Board is level to the bottom of the car, front to rear, not level to the ground. Adjust the Brackets as necessary to line up the Running Board with the side of the vehicle. Move to the rear Bracket and once aligned, tighten the 10mm Lock Nut on the Bolt Plate, **(Figure 13)**.
14. Next, move to the front Bracket. Tighten the Bolt Plate and Carriage Bolt hardware only, **(Figures 3A & 4A)**. Adjust the height of the front Bracket as necessary. Once properly adjusted, tighten the 10mm Hex Bolt securing the Support Bracket to the front Mounting Bracket, **(Figure 5)**.
15. With the front and rear Brackets fully tightened to the vehicle, move to the Center Bracket. Fully tighten the 10mm Lock Nut securing the Support Bracket to the Bolt Plate, **(Figure 16)**. Gently push the Mounting Bracket up against and level to the bottom of the Running Board. Tighten the (2) 8mm Hex Bolts. Slowly tighten the 10mm x 40mm Hex Adjustment Bolt until the Reinforcement Plate is snug against the bottom of the body panel. Turn the Hex Bolt 1/2 to 1 full turn tighter to add preload. Tighten the 10mm Hex Nut to lock the 10mm x 40mm Hex Bolt in the Bracket, **(Figure 16)**.
16. Once properly adjusted, fully tighten all Bracket hardware first. Check for front to back adjustment on the Running Board and tighten all 6mm Running Board to Bracket hardware, **(Figures 15 & 16)**.
17. Repeat **Steps 2—17** for the passenger side Running Board installation.
18. Do periodic inspections to the installation to make sure that all hardware is secure and tight.

### Driver Side Installation Pictured

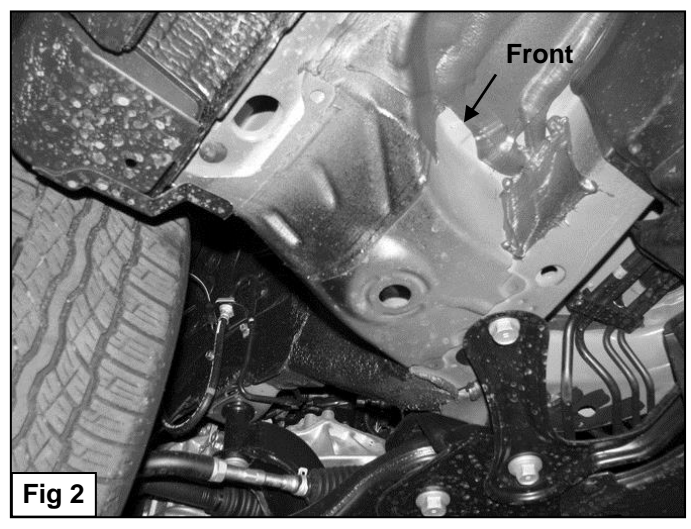
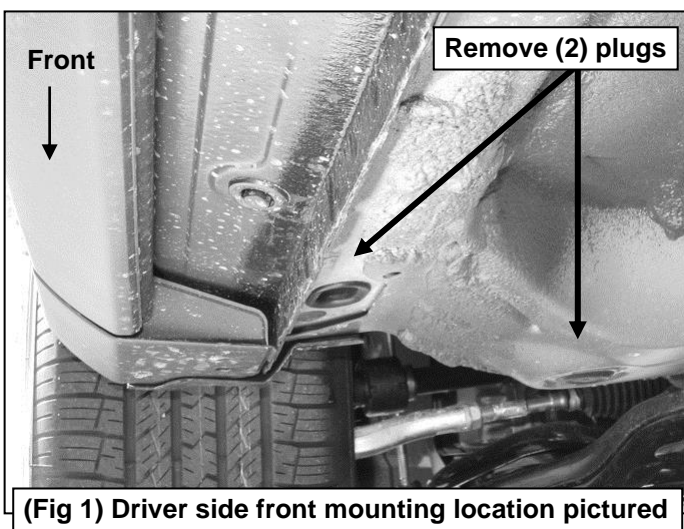

**Driver Side Installation Pictured**

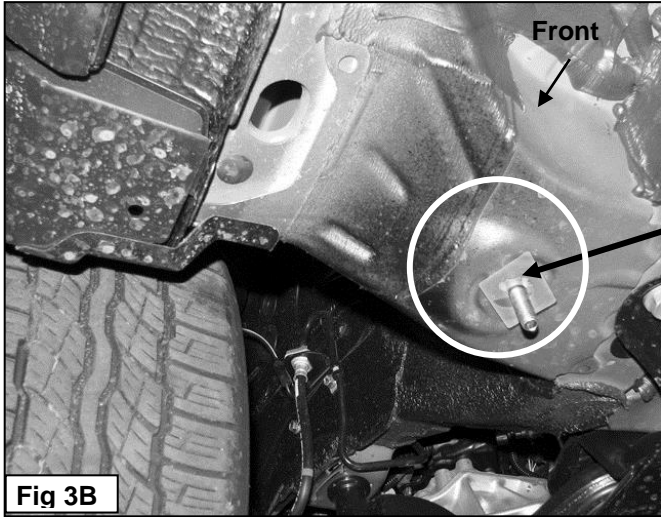

**Fig 3B**

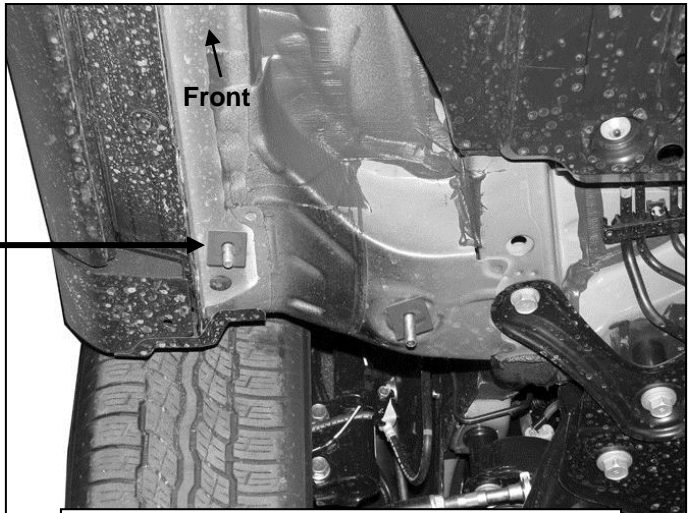
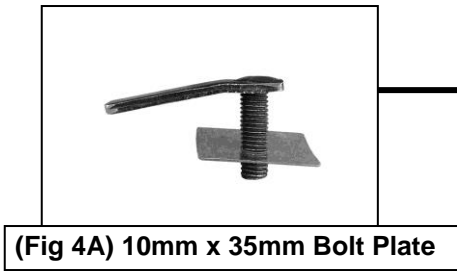
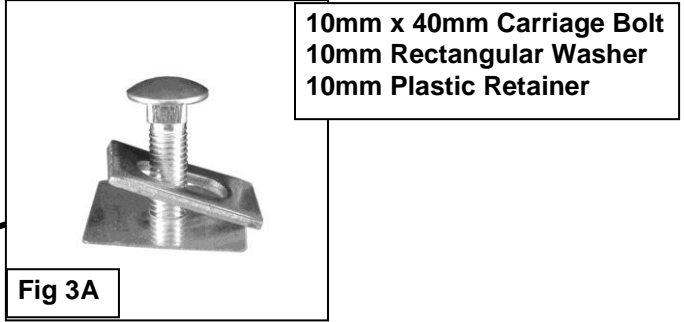

**(Fig 4B) Driver side front location pictured**

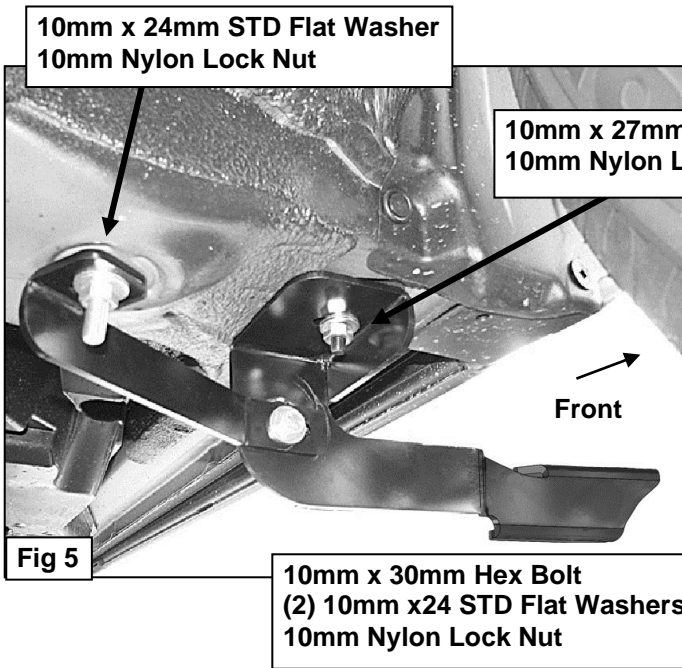

# Driver Side Installation Pictured

From the front fender opening, locate the 4th and 5th rubber plugs along the floor panel

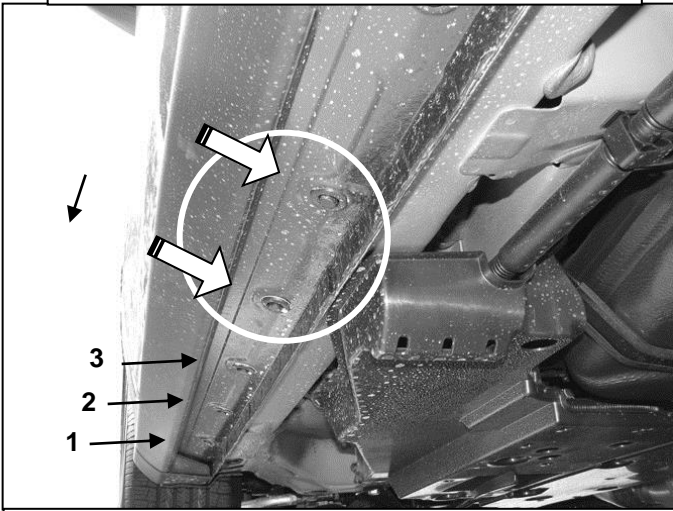

Fig 6) Driver side Center Bracket location pictured



(Fig 7A) 10mm x 50mm Bolt Plate

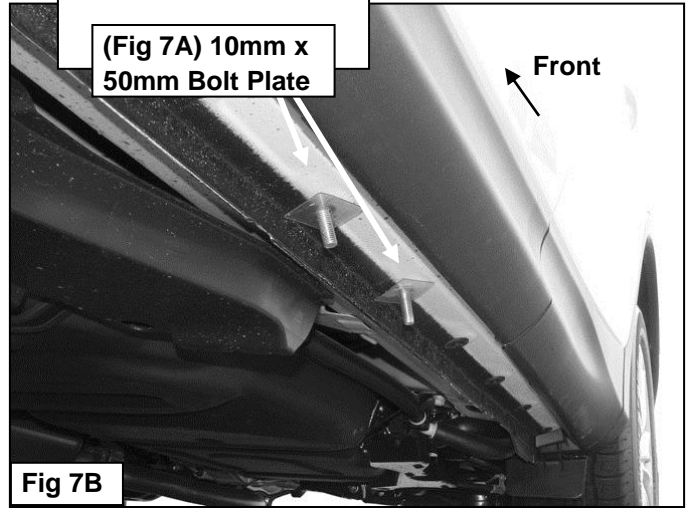
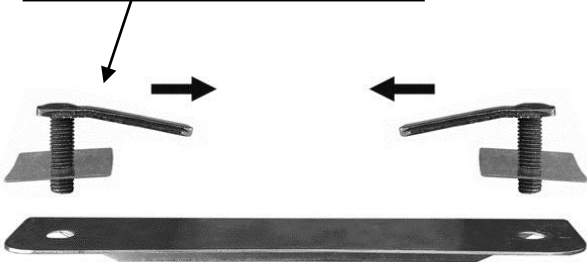

Fig 7B

(2) 10mm x 50mm Bolt Plates



Lock Plate

(Fig 7C) Install Bolt Plates with Plates pointing towards each other

10mm x 27mm Large Flat Washer  
10mm Nylon Lock Nut

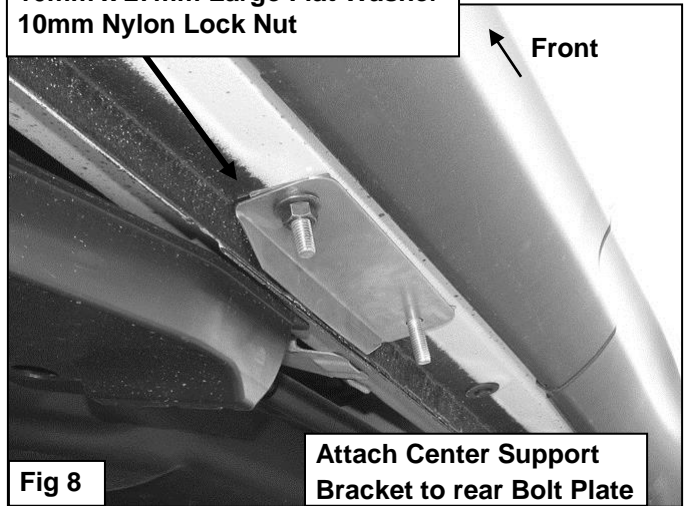
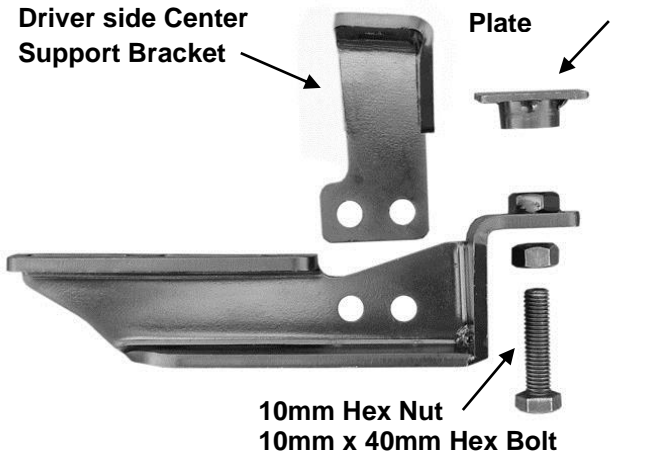

Fig 8

Attach Center Support Bracket to rear Bolt Plate

Driver side Center Support Bracket

Reinforcement Plate



10mm Hex Nut  
10mm x 40mm Hex Bolt

(Fig 9) Driver side Center Bracket assembly pictured

### Driver Side Installation Pictured

- (2) 8mm x 30mm Hex Bolts
- (4) 8mm Flat Washers
- (2) 8mm Nylon Lock Nuts

- 10mm x 24mm STD Flat Washer
- 10mm Nylon Lock Nut

Front

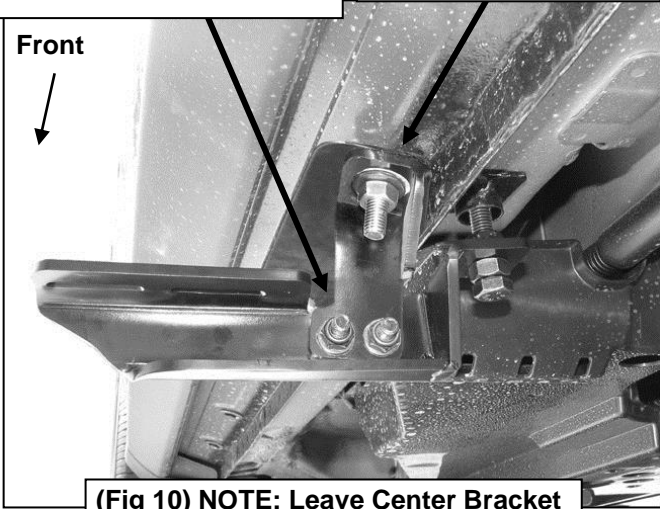

(Fig 10) NOTE: Leave Center Bracket hardware loose until final steps

Remove plug

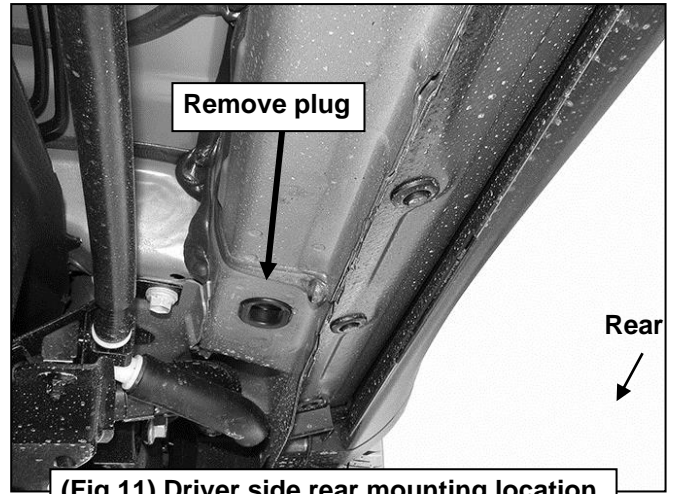

(Fig 11) Driver side rear mounting location

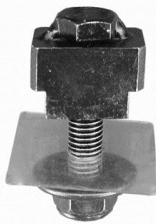

(Fig 12A) 6mm T-Bolt

10mm x 35mm Bolt Plate

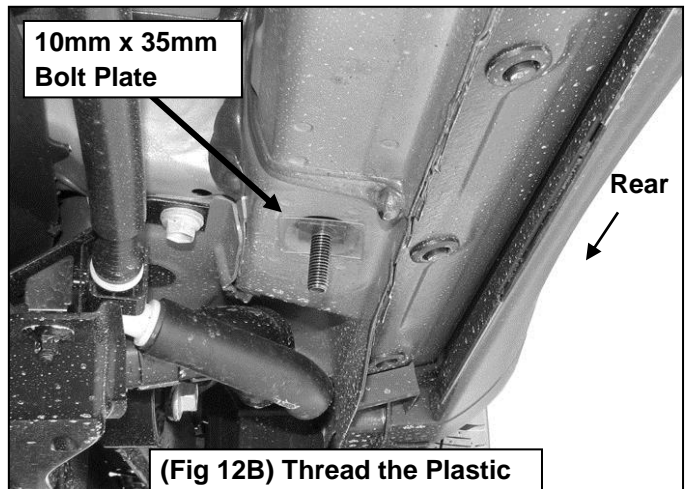

(Fig 12B) Thread the Plastic Retainer onto the Bolt Plate

- 10mm x 27mm Large Flat Washer
- 10mm Nylon Lock Nut

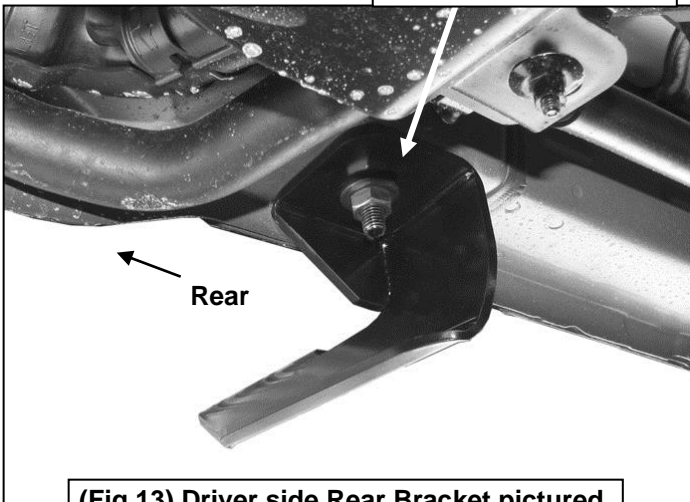

(Fig 13) Driver side Rear Bracket pictured

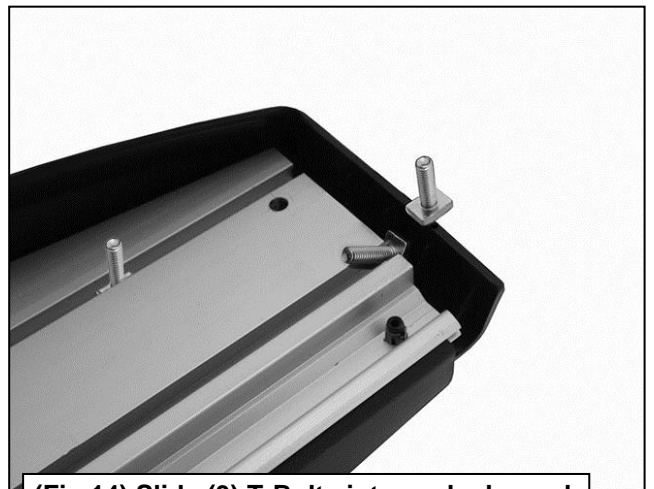

(Fig 14) Slide (3) T-Bolts into each channel

## Driver Side Installation Pictured

10mm x 27mm Large Flat Washer  
10mm Nylon Lock Nut

(2) 6mm T- Bolts  
(2) 6mm Flat Washers  
(2) 6mm Lock Washers  
(2) 6mm Hex Nuts

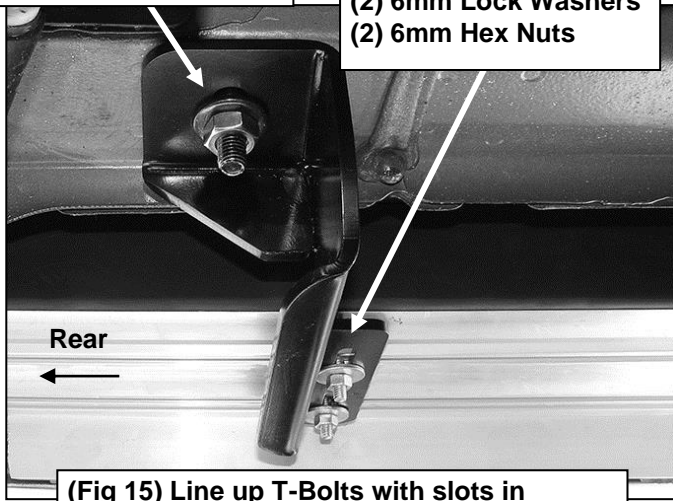

(Fig 15) Line up T-Bolts with slots in Brackets. Driver side rear Bracket pictured

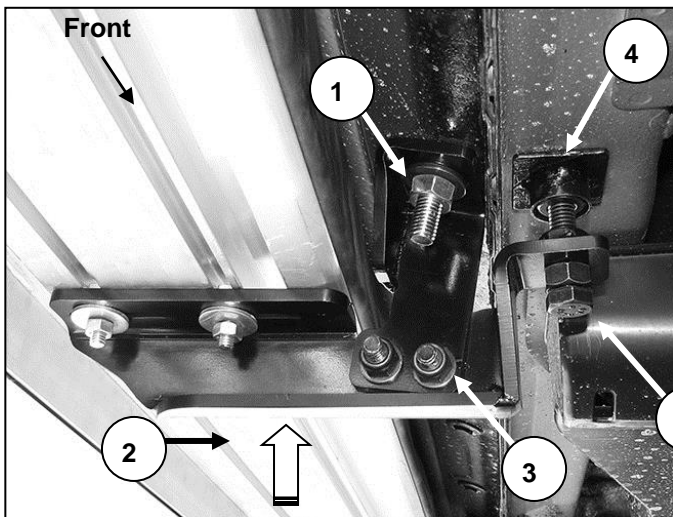

(Fig 16) Driver side Center Bracket pictured

Once the Running Board has been aligned and the front and rear brackets fully tightened, adjust the height of the Center Bracket:

1. Tighten the 10mm x 50mm Bolt Plate hardware
2. Hold the Bracket level and against the bottom of the Running Board
3. Tighten the (2) 8mm Hex Bolts
4. Tighten the 10mm x 40mm Hex Bolt until the Reinforcement Plate is snug up against the floor panel
5. Turn Hex Bolt 1/2 to 1 full turn and tighten jam nut to lock adjustment. Readjust as necessary

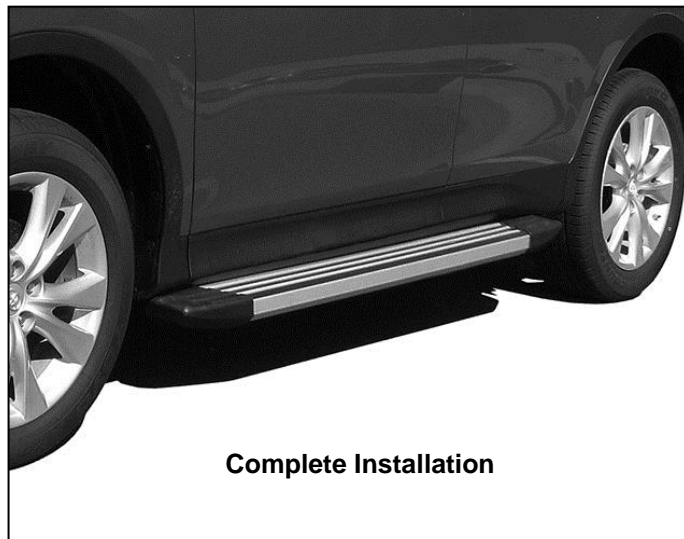

Complete Installation

## PARTS IDENTIFICATION GUIDE

**Driver Side tube packed using "Green" color foam sheet. Passenger Side tube packed using "White" color foam sheet**

No.	Parts Identification	
1	Passenger / Right 'Rear' Bracket marked "PR"	
2	Driver / Left 'Rear' Bracket marked "DR"	
3	Passenger / Right 'Center' Bracket marked "PC"	
4	Driver / Left 'Center' Bracket marked "DC"	
5	Passenger / Right 'Front' Bracket marked "PF"	
6	Driver / Left 'Front' Bracket marked "DF"	
<b>Note:</b>		
<ul style="list-style-type: none"> <li>➤ This guide is to identify the parts and not a reference for part count.</li> <li>➤ For part count, refer Parts List.</li> <li>➤ Product / Bracket image is representative and actual design may vary.</li> </ul>		

## PRODUCT CARE

- Periodically check the product to ensure all fasteners are tight and components are intact.
- Regular waxing is recommended to protect the finish of the product.
- **Use ONLY Non-Abrasive automotive wax.** Use of any soap, polish or wax that contains an abrasive is detrimental and can scratch the finish leading to corrosion.
- Aluminum polish may be used to polish small scratches and scuffs for **Stainless Steel finish.**
- Mild soap may be used to clean the product for both **Stainless Steel and Black finish.**

## FAQ's

### 1. Hardware's are not of correct size.

*In GMC / Chevrolet truck model 2006 & up, customer needs to reuse the factory body bolts to install the bracket. If your vehicle is not GMC / Chevrolet 2006 & up, ensure that holes are not partially covered with any plastic grommet or rust? If it is, remove the plastic grommet & rust from the thread holes & re-try the installation.*

### 2. Mounting Bracket are not getting Installed properly.

*In some cases Illustration images shown in Installation manual may not be the exactly same as per actual vehicle images ,also if Driver / Passenger side mounting brackets are very identical in the design, suggest referring Parts Identification guide to avoid fitment issue.*

### 3. Products are thumping / rattling after installation.

*Ensure that all required mounting brackets / hardware's are installed & tighten correctly. Suggest using white lithium / regular grease between the metal to metal contact surfaces.*

### 4. Side Bar is not aligning with vehicle / Step Pads are not aligning with vehicle doors.

*Side bar may be interchanged or mounting brackets are not installed at the correct position in the vehicle. Refer Parts identification guide.*

### 5. Missing / Excess Hardware.

*Recheck hardware count as per the part list.*

### 6. Product not installing properly.

*Ensure make model year, cab length and bed size of your vehicle is listed in the application. All installation steps are followed correctly.*

## Check out these other TrailFX Products!!



**SIDE BAR**

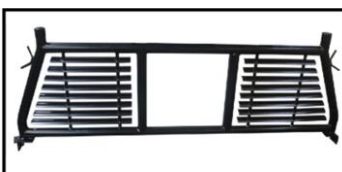

**HEADACHE RACKS**



**BULL BARS**



**ROCKER GUARDS**

Keystone Automotive Operations Inc. (KAO) warrants this product to be free of defects in material and workmanship at the time of purchase by the original retail consumer. KAO disclaims any other warranties, express or implied, including the warranty of fitness for a particular purpose or an intended use. If the product is found to be defective, KAO may replace or repair the product at our option, when the product is returned prepaid, with proof of purchase. Alteration to, improper installation, or misuse of this product voids the warranty. KAO's liability is limited to repair or replacement of products found to be defective, and specifically excludes liability for any incidental or consequential loss or damage.