



# Running Board

Part No. R0012MK/R0008RB



Fits: 2009-2015

Honda Pilot



60-180 min

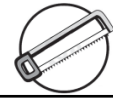

Cutting Required



Drilling Not Required



REMOVE CONTENTS FROM BOX. VERIFY ALL PARTS ARE PRESENT.



READ INSTRUCTIONS CAREFULLY BEFORE STARTING INSTALLATION.

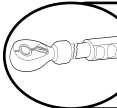

DO NOT OVER TORQUE. STANDARD OPERATING LOAD FOR TIGHTEN BODY MOUNT NUTS & BOLTS VARIES FROM 45 TO 65 FOOT POUND.

### PARTS LIST:

Qty	Part Description	Qty	Part Description
1	Driver side running board	1	8mm Insert Installation Tool
1	Passenger side running board	4	10-1.50mm x 35mm Hex Bolt
1	Driver Front Mounting Bracket	10	10mm x 24mm OD x 2.2mm Flat Washer
1	Passenger Front Mounting Bracket	6	10mm Lock Washer
1	Driver Front Support Bracket	6	10-1.50mm Hex Nut
1	Passenger Front Support Bracket	12	8-1.25mm x 25mm Hex Bolt
1	Driver Center Mounting Bracket	12	8mm Lock Washer
1	Passenger Center Mounting Bracket	12	8mm x 22mm x 2mm Flat Washers
1	Driver Rear Mounting Bracket	12	6-1.0 x 20mm T-Bolts
1	Passenger Rear Mounting Bracket	12	6mm x 22mm OD x 2mm Flat Washer
2	10-1.50mm x 40mm Bolt Plate	12	6mm Lock Washer
2	8-1.25mm Threaded Insert	12	6-1.0mm Hex Nuts

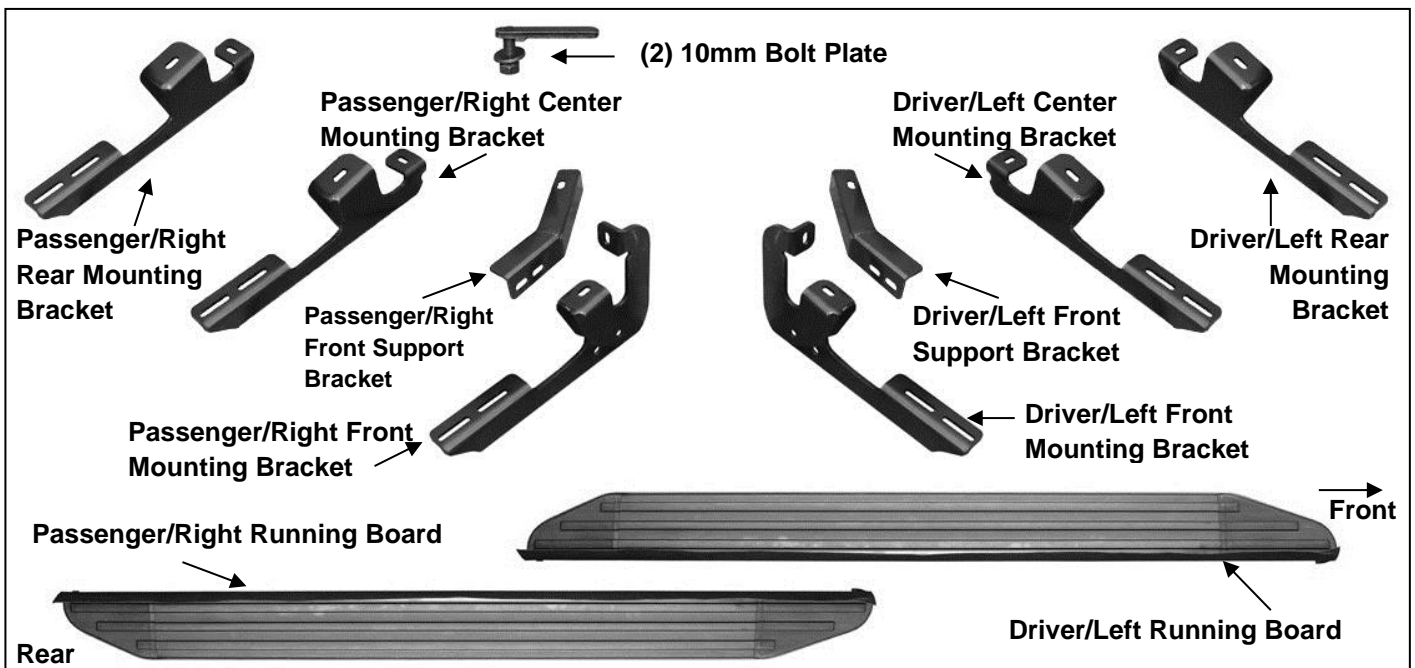

## INSTALLATION PROCEDURE:

1. Starting on the driver side of the vehicle, locate the two factory 8mm threaded holes, one located in the bottom of the floor panel and the second in the side of the inner body panel, (**Figure 1**). **IMPORTANT:** All factory threaded holes may be covered with rubber plugs or undercoating. Scrape off any excess undercoating from mounting surfaces.
2. Select the driver side Front Mounting Bracket. Attach the Bracket to the two threaded holes using the provided (2) 8mm x 25mm Hex Bolts, (2) 8mm Lock Washers and (2) 8mm Flat Washers. Snug but do not tighten hardware at this time, (**Figure 2**).

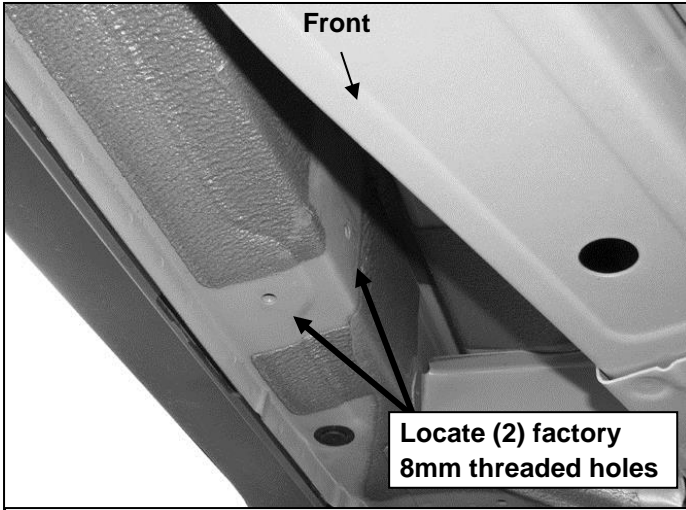

(Fig 1) Driver side front mounting location pictured

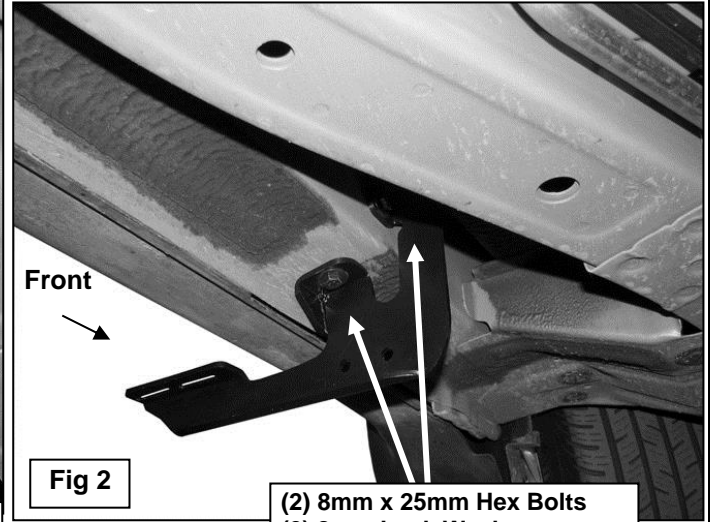

Fig 2

(2) 8mm x 25mm Hex Bolts  
(2) 8mm Lock Washers  
(2) 8mm Flat Washers

3. Select (1) 10mm Bolt Plate, (**Figure 3**). Insert the Bolt Plate into the factory hole in the bottom of the frame channel, (**Figure 4**). Rotate the Bolt Plate clock-wise 90-degrees or until it stops turning. **NOTE:** To help determine the correct inner mounting hole on the frame to use, hold the Support Bracket up to the back of the Front Bracket with the inner end lined up with the hole in the bottom of the frame channel, (**Figure 5**).



(Fig 3) 10mm Bolt Plate

10mm Flat Washer  
10mm Lock Washer  
10mm Hex Nut

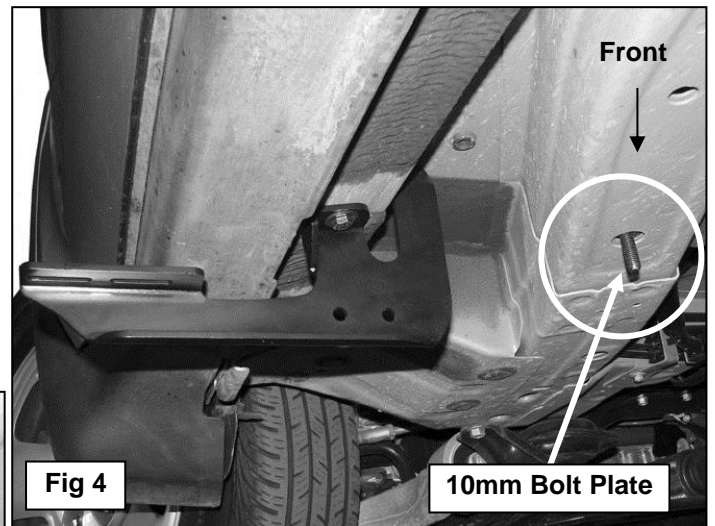

Fig 4

10mm Bolt Plate

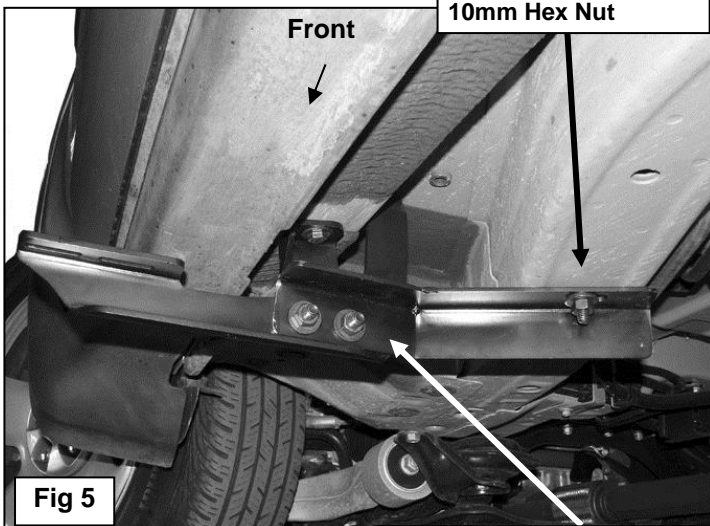
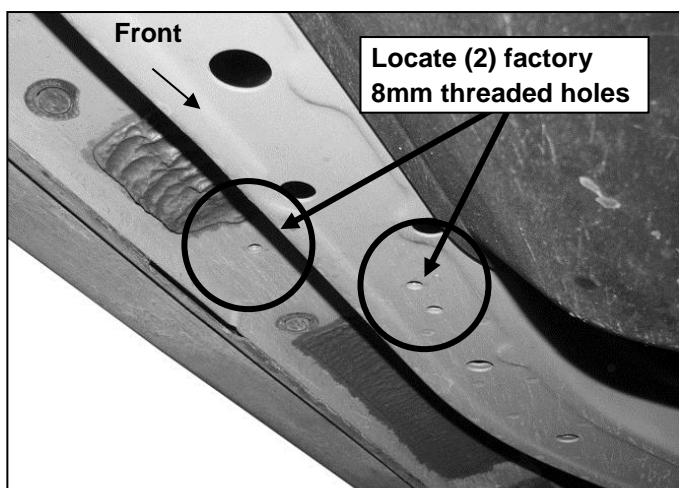

Fig 5

(2) 10mm x 35mm Hex Bolts  
(4) 10mm Flat Washers  
(2) 10mm Lock Washers  
(2) 10mm Hex Nuts

4. Bolt the driver side Support Bracket to the back of the front Mounting Bracket with (2) 10mm x 35mm Hex Bolts, (4) 10mm Flat Washers, (2) 10mm Lock Washers and (2) 10mm Hex Nuts, **(Figure 5)**. Next, hang the inner end of the Support Bracket from the previously installed Bolt Plate using (1) 10mm Flat Washer, (1) 10mm Lock Washer and (1) Hex Nut. Do not fully tighten hardware at this time.
5. Next, move to the center of the vehicle and locate the (2) 8mm threaded holes located on the bottom of the floor panel and bottom of the frame channel, **(Figure 6)**. Select the driver side Center Mounting Bracket, **(Figure 7)**. **IMPORTANT:** Center and Rear Brackets are similar but unique. To help identify, the Center Brackets feature a notch cut out of the inner end of the Bracket, **(Figure 7)**. Attach the Center Bracket to the two threaded holes using the provided (2) 8mm x 25mm Hex Bolts, (2) 8mm Lock Washers and (2) 8mm Flat Washers, **(Figure 8)**. Snug but do not tighten hardware at this time.
6. Continue along the side of the vehicle to the rear mounting location. Locate the 8mm threaded hole in the bottom of the frame channel, **(Figure 9)**. Locate the factory hole in the bottom of the floor panel. Remove rubber plugs as necessary. **NOTE:** To determine the correct mounting holes to use, hold the driver side rear Mounting Bracket up in position against the factory threaded hole in the end of the frame channel, **(Figure 9)**. Remaining hole in mounting tab on the bracket will line up with correct factory hole in floor panel.



**(Fig 6) Driver side center mounting location pictured**

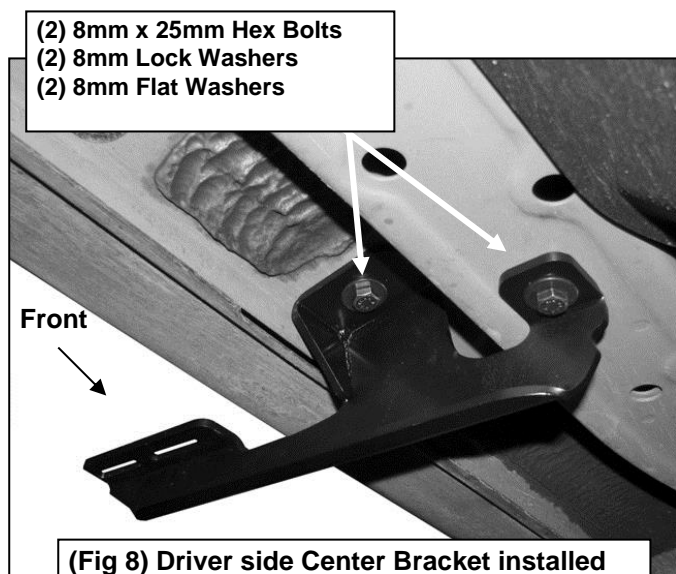
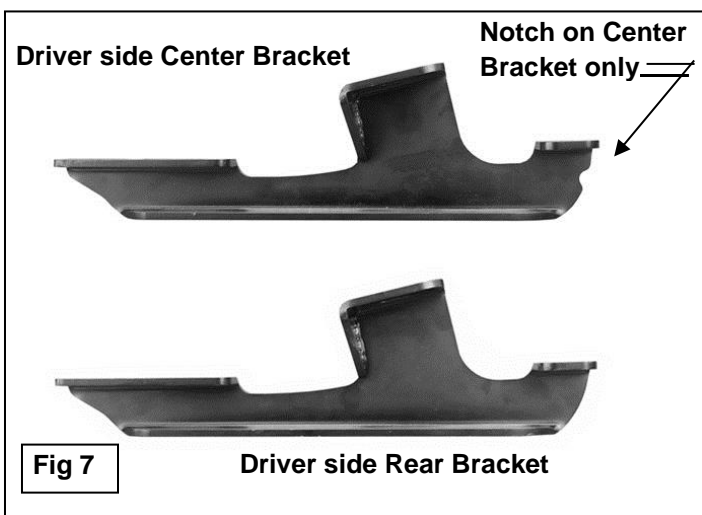

**(Fig 8) Driver side Center Bracket installed**

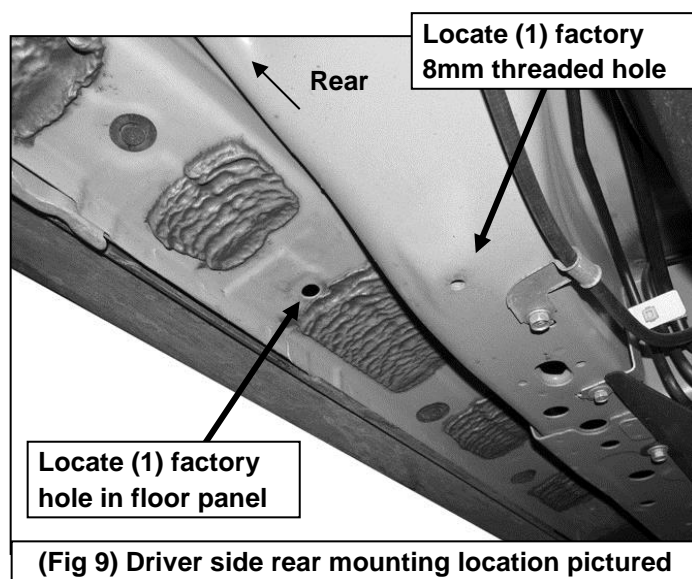

**(Fig 9) Driver side rear mounting location pictured**

7. Select the 8mm Threaded Insert Tool, (1) 8mm Threaded Insert, (1) 8mm Flat Washer and (1) 8mm x 25mm Hex Bolt, **(Figure 10)**. Assemble the tool as pictured in **Figure 10**. Insert the assembly into the factory hole. Firmly hold the tool handle and assembly up tight against the floor panel and tighten the 8mm Hex Bolt until the insert is fully expanded in the hole, **(Figure 11)**. **NOTE:** Do not over tighten or a pull out may occur. Once Insert is fully compressed, remove the bolt and tool from the Insert.

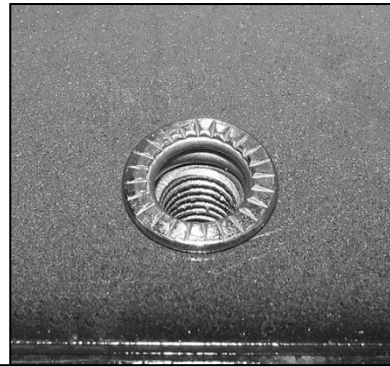
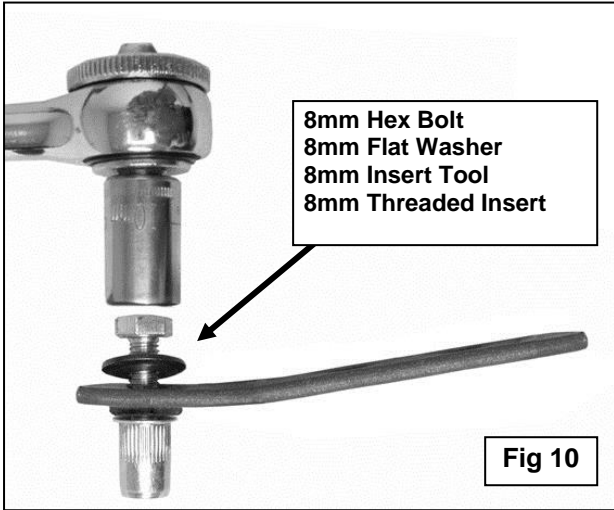

(Fig 11) Tighten Hex Bolt to collapse and lock Threaded Insert into factory hole

8. Attach the driver side Rear Bracket to the (2) threaded holes with (2) 8mm x 25mm Hex Bolts, (2) 8mm Lock Washers and (2) 8mm Flat Washers, (Figure 13). Do not tighten hardware at this time.

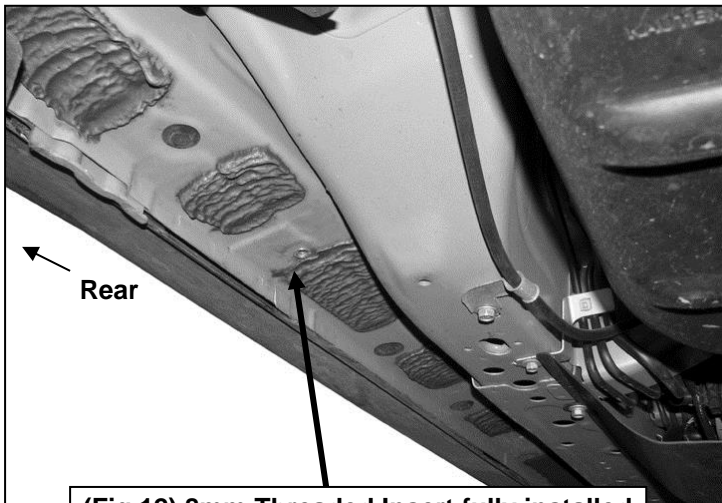

(Fig 12) 8mm Threaded Insert fully installed

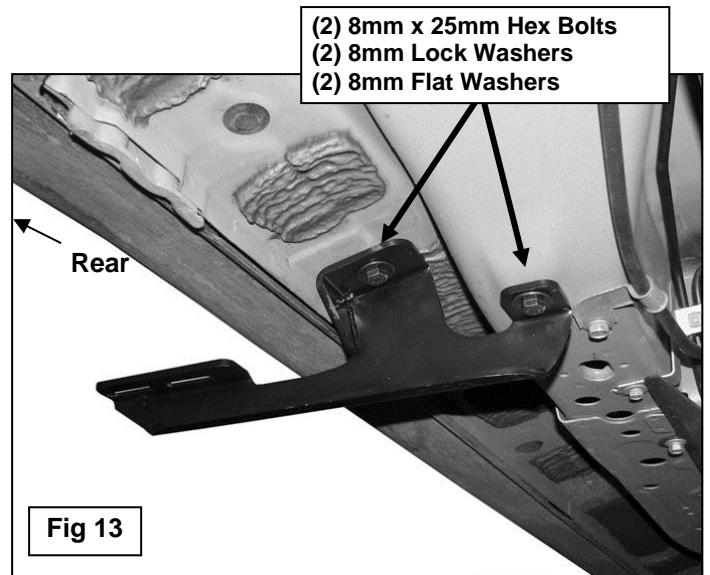

9. Select the driver/left side Running Board. Locate the openings cut at the end of the slots on the bottom of the Running Board, (**Figure 14**). Insert (3) 6mm T-Bolts into each channel through the openings. Slide the T-Bolts into the approximate position in line with the (3) Brackets on the vehicle.
10. Carefully position the Driver/Left Running Board onto the (3) Mounting Brackets. Slide the T-Bolts into position and through the slots in the Brackets. Attach the Board to the Brackets with (6) 6mm Flat Washers, (6) 6mm Lock washers and (6) 6mm Hex Nuts, (**Figure 15**). Do not tighten hardware at this time.

Slide 6mm T-Bolts into slot at end of channel

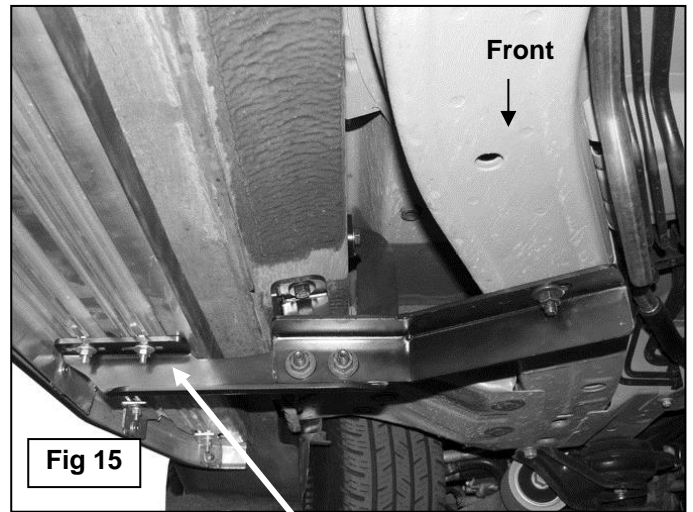
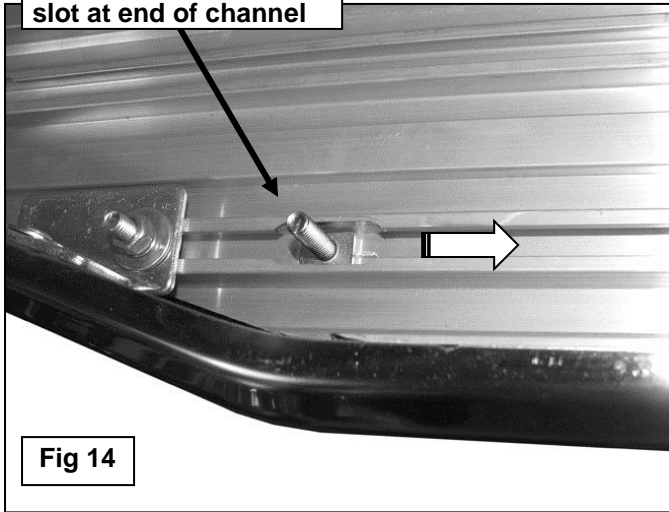

6mm Flat Washers  
6mm Lock Washers  
6mm Hex Nuts

11. Level and adjust the Running Board and tighten all hardware.
12. Repeat **Steps 1 - 11** for the passenger/right Running Board installation.
13. Do periodic inspections to the installation to make sure that all hardware is secure and tight.

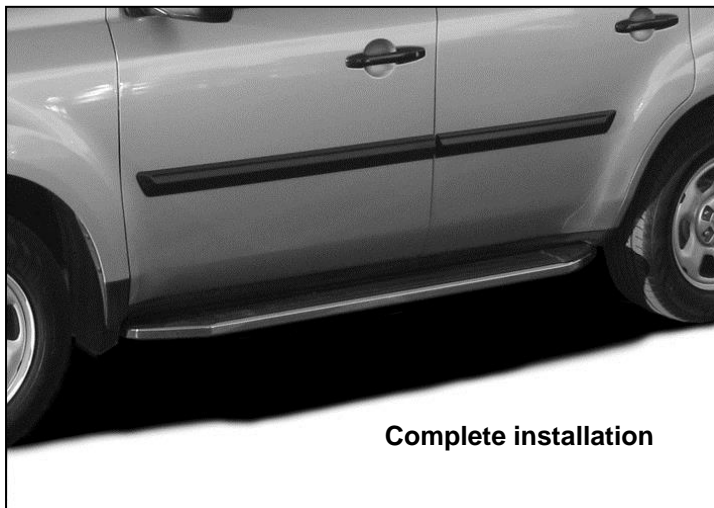



No.	Parts Identification
1	Passenger / Right 'Rear' Bracket marked "PR"
2	Driver / Left 'Rear' Bracket marked "DR"
3	Passenger / Right 'Center' Bracket marked "PC"
4	Driver / Left 'Center' Bracket marked "DC"
5	Passenger / Right 'Front' Bracket marked "PF"
6	Driver / Left 'Front' Bracket marked "DF"

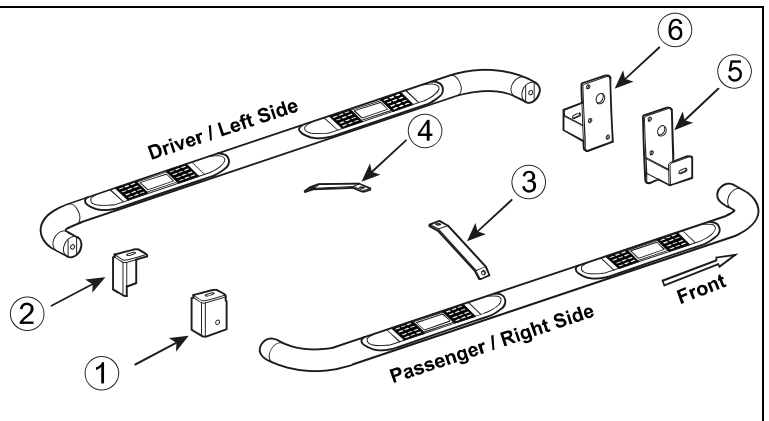

**Note:**

- This guide is to identify the parts and not a reference for part count.
- For part count, refer Parts List.
- Product / Bracket image is representative and actual design may vary.

**PRODUCT CARE**

- Periodically check the product to ensure all fasteners are tight and components are intact.
- Regular waxing is recommended to protect the finish of the product.
- **Use ONLY Non-Abrasive automotive wax.** Use of any soap, polish or wax that contains an abrasive is detrimental and can scratch the finish leading to corrosion.
- Aluminum polish may be used to polish small scratches and scuffs for **Stainless Steel finish.**
- Mild soap may be used to clean the product for both **Stainless Steel and Black finish.**

**FAQ's**

- 1. Hardware's are not of correct size.**  
*In GMC / Chevrolet truck model 2006 & up, customer needs to reuse the factory body bolts to install the bracket. If your vehicle is not GMC / Chevrolet 2006 & up, ensure that holes are not partially covered with any plastic grommet or rust? If it is, remove the plastic grommet & rust from the thread holes & re-try the installation.*
- 2. Mounting Bracket are not getting Installed properly.**  
*In some cases Illustration images shown in Installation manual may not be the exactly same as per actual vehicle images ,also if Driver / Passenger side mounting brackets are very identical in the design, suggest referring Parts Identification guide to avoid fitment issue.*
- 3. Products are thumping / rattling after installation.**  
*Ensure that all required mounting brackets / hardware's are installed & tighten correctly. Suggest using white lithium / regular grease between the metal to metal contact surfaces.*
- 4. Side Bar is not aligning with vehicle / Step Pads are not aligning with vehicle doors.**  
*Side bar may be interchanged or mounting brackets are not installed at the correct position in the vehicle. Refer Parts identification guide.*
- 5. Missing / Excess Hardware.**  
*Recheck hardware count as per the part list.*
- 6. Product not installing properly.**  
*Ensure make model year, cab length and bed size of your vehicle is listed in the application. All installation steps are followed correctly.*

**Check out these other TrailFX Products!!**



Keystone Automotive Operations Inc. (KAO) warrants this product to be free of defects in material and workmanship at the time of purchase by the original retail consumer. KAO disclaims any other warranties, express or implied, including the warranty of fitness for a particular purpose or an intended use. If the product is found to be defective, KAO may replace or repair the product at our option, when the product is returned prepaid, with proof of purchase. Alteration to, improper installation, or misuse of this product voids the warranty. KAO's liability is limited to repair or replacement of products found to be defective, and specifically excludes liability for any incidental or consequential loss or damage.