



Running Board

Part No. R0001RB/R0008MK



Fits: 2007 - Current

Honda CRV

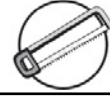

60-180 min

Cutting Required

Drilling Not Required



REMOVE CONTENTS FROM BOX. VERIFY ALL PARTS ARE PRESENT.



READ INSTRUCTIONS CAREFULLY BEFORE STARTING INSTALLATION.

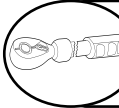

DO NOT OVER TORQUE. STANDARD OPERATING LOAD FOR TIGHTEN BODY MOUNT NUTS & BOLTS VARIES FROM 45 TO 65 FOOT POUND.

PARTS LIST:

Qty	Part Description	Qty	Part Description
1	Driver/Left Running Board	2	10mm Lock Washers
1	Passenger/Right Running Board	20	8mm x 25mm Hex Bolts
2	Front Mounting Bracket Arms	28	8mm x 22mm OD x 2mm Flat Washers
2	Rear Mounting Bracket Arms	20	8mm Lock Washers
4	Outer Support Brackets	8	8mm Hex Nuts
1	Driver/Left Rear Inner Support Bracket	8	6mm "T" bolts
1	Passenger/Right Rear Inner Support Bracket	8	6mm x 22mm OD x 2mm Flat Washers
2	10mm x 20mm Hex Bolts	8	6mm Lock Washers
2	10mm x 20mm OD x 2mm Flat Washers	8	6mm Hex Nuts

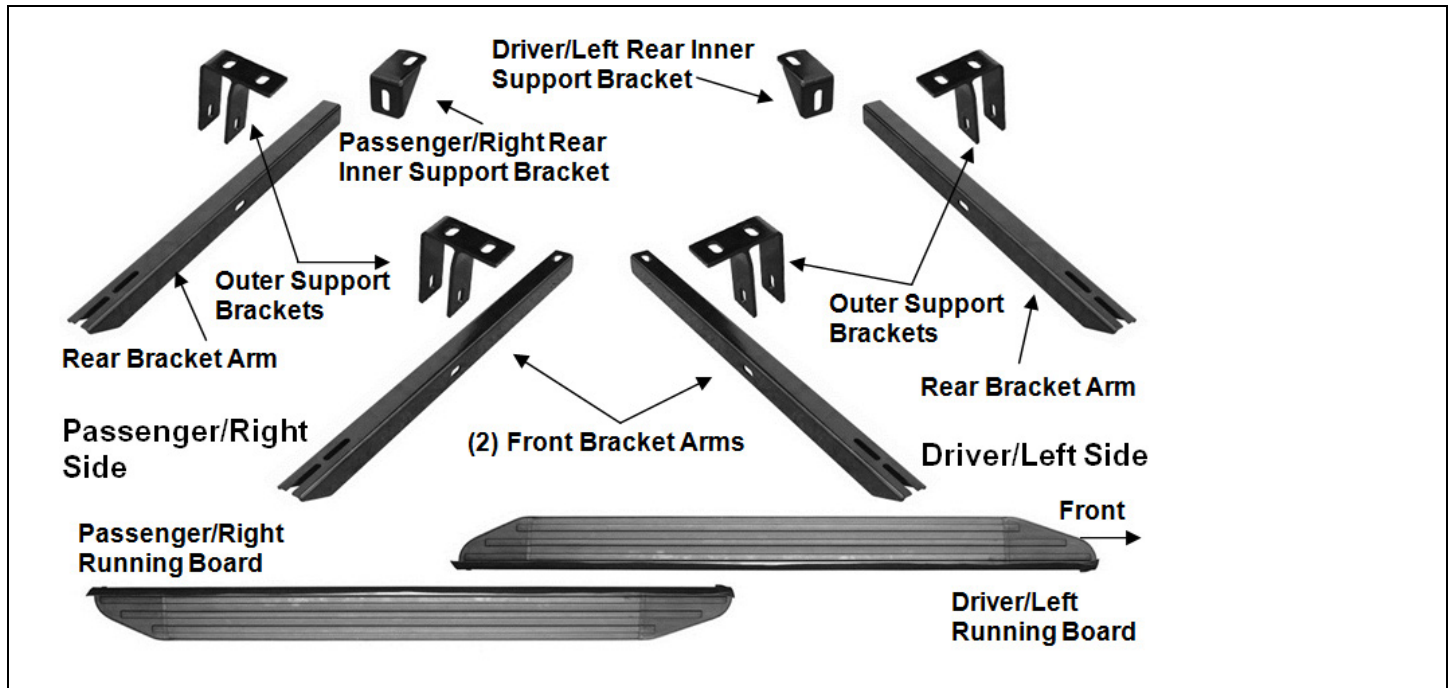

Install Note: 200lbs is the maximum rated load for the viewpoint running boards.

INSTALLATION PROCEDURE

1. Identify and separate the driver and passenger side front and rear Mounting Brackets. Start installation on the driver/left side of the vehicle.
2. Cut out the paper template on **Page 7** labeled "Driver Side," (**Figure 1**). Cut out the square section on the bottom of the Template and the (2) 8mm holes on the top. Fold the top of the Template up along the dotted line, (**Figure 2**). Hold the Template in place over the outer (2) factory 8mm threaded holes next to the pinch weld, (**Figures 3 & 4**). **IMPORTANT:** There are (4) threaded holes at each mounting location, (2) inner on bottom of frame channel and (2) outer next to pinch weld, (**Figure 5**). Hold the correct Template over the outer threaded holes and up against the plastic cover, (**Figure 4**). Use a marker to trace the cut out section on the bottom of the Template onto the plastic cover. Repeat this Step to mark the rear bracket location for cutting.

Driver Side Installation Pictured Without Plastic Cover for Instruction Purposes Only

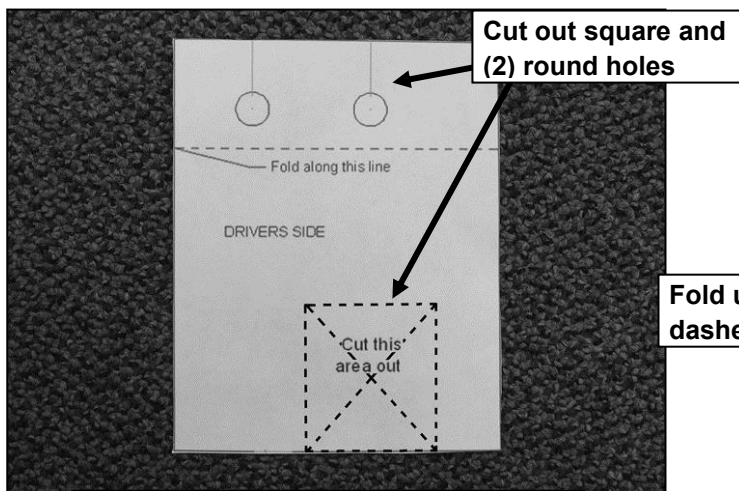

(Fig 1) Driver side Template pictured

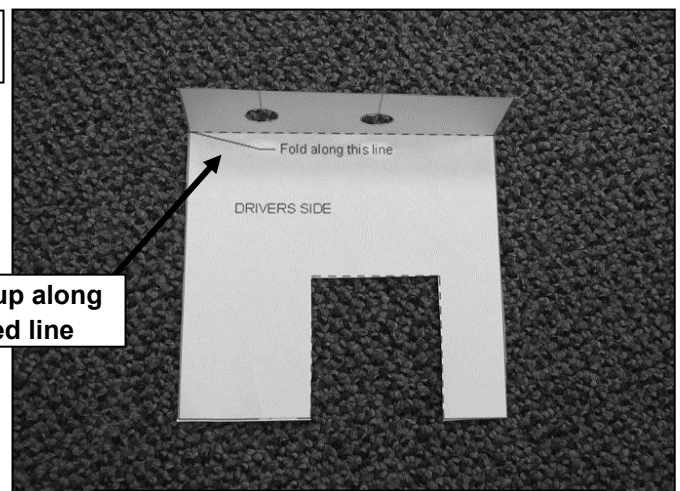

(Fig 2) Driver side Template pictured

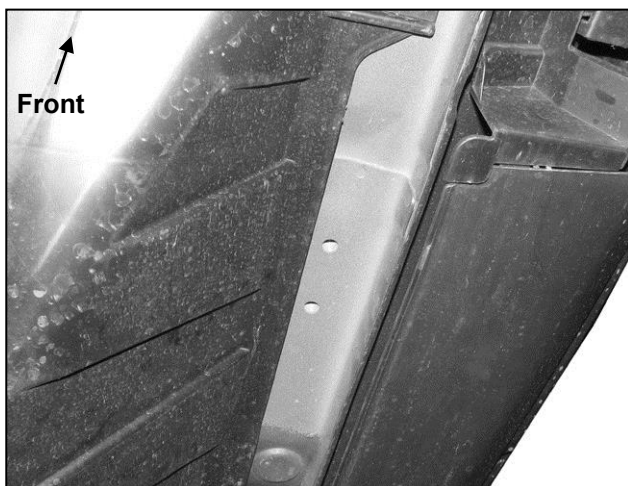

(Fig 3) Driver side front mounting location pictured



(Fig 4) Front driver side location pictured

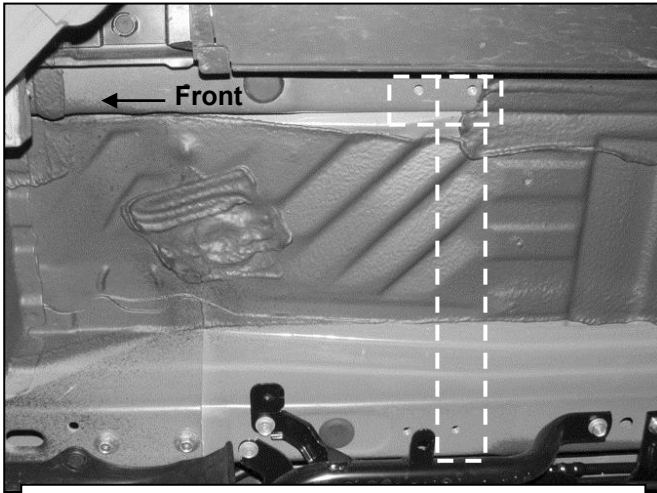

(Fig 5) Dashed line represents driver side front mounting location for Bracket assembly

With the plastic cover in place, hold the paper template (Driver side pictured) over the (2) threaded holes next to the pinch weld. Use a marker to trace the square cut out section on the template. Remove cover. Use a utility knife or hacksaw to carefully cut out this section. Check the clearance between the Bracket and the cover often for proper fit

3. Remove the plastic cover. Cut out the (2) sections as marked. **VERY IMPORTANT:** The Templates are driver and passenger side specific and have been provided for reference use only. It is the installer's responsibility to be absolutely sure that the correct location has been marked before cutting the plastic cover. To verify the locations before cutting, temporarily assemble the Mounting Brackets as pictured on **Page 1** and check the locations on the cover.
4. Partially install the plastic cover. **IMPORTANT:** Attach the cover to the vehicle with the outer, (next to pinch weld), hardware only. Allow the cover to hang in place from the outer hardware. Do not install inner hardware at this time.
5. Locate the forward (2) 8mm threaded holes in the floor panel, (See **Step 3, Fig. 3**). Select (1) Outer Support Bracket. Bolt the Bracket to the threaded holes with (2) 8mm Hex Bolts, (2) 8mm Lock Washers, and (2) 8mm Flat Washers, (**Figure 6**). Snug but do not fully tighten hardware at this time.
6. Select (1) Front Bracket Arm, (**Figure 7**). Insert the Bracket Arm through the tabs on the Support Bracket and into the hole cut out of the plastic cover. Line up the inner end of the Bracket with the rear threaded hole on the bottom of the frame channel in line with the outer holes, (**Figure 8**). Attach the Bracket to the frame channel with (1) 8mm Hex Bolt, (1) 8mm Lock Washer and (1) 8mm Flat Washer. Bolt the Bracket Arm to the (2) tabs on the Support Bracket with (2) 8mm x 25mm Hex Bolts, (4) 8mm Flat Washers, (2) 8mm Lock Washers and (2) 8mm Hex Nuts, (**Figure 9**). **NOTE:** Mounting tab on outer Support Bracket will go toward front of vehicle. Do not tighten hardware at this time.
7. Locate the rear (2) 8mm threaded holes in the floor panel, (See **Step 3**). Select (1) Outer Support Bracket. Bolt the Bracket to the threaded holes with (2) 8mm Hex Bolts, (2) 8mm Lock Washers, and (2) 8mm Flat Washers, (**Figure 6**). Snug but do not fully tighten hardware at this time.
8. Next, select the driver side rear Inner Support Bracket and (1) Rear Bracket Arm. Bolt the Support Bracket to the end of the Arm with (1) 10mm x 20mm Hex Bolt, (1) 10mm Lock Washer and (1) 10mm Flat Washer, (**Figures 9 & 10**). Do not tighten at this time.
9. Insert the rear Bracket Arm through the (2) tabs on the Support Bracket and into the hole cut out of the plastic cover. Line up the tab on the Support Bracket with the rear threaded hole on the bottom of the frame channel in line with the outer holes, (**Figure 10**). Attach the Bracket to the frame channel with (1) 8mm Hex Bolt, (1) 8mm Lock Washer and (1) 8mm Flat Washer. Bolt the Bracket Arm to the (2) tabs on the Support Bracket with (2) 8mm x 25mm Hex Bolts, (4) 8mm Flat Washers, (2) 8mm Lock Washers and (2) 8mm Hex Nuts, (**Figure 11**). **NOTE:** Mounting tab on Support Bracket will go toward front of vehicle, (**Figures 8 & 9**). Do not tighten hardware at this time.

Driver Side Installation Pictured Without Plastic Cover for Instruction Purposes Only

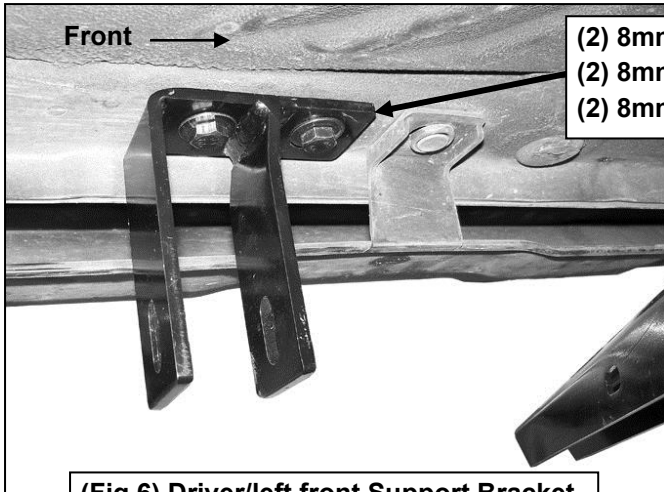

(Fig 6) Driver/left front Support Bracket

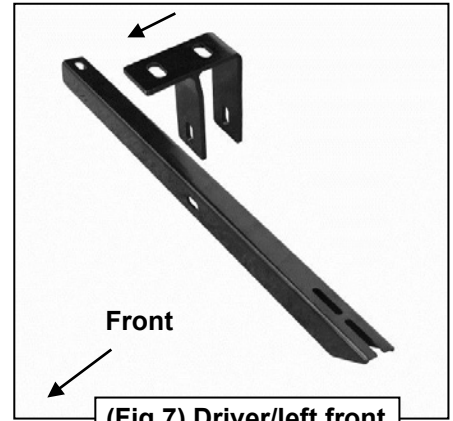

(Fig 7) Driver/left front Bracket assembly

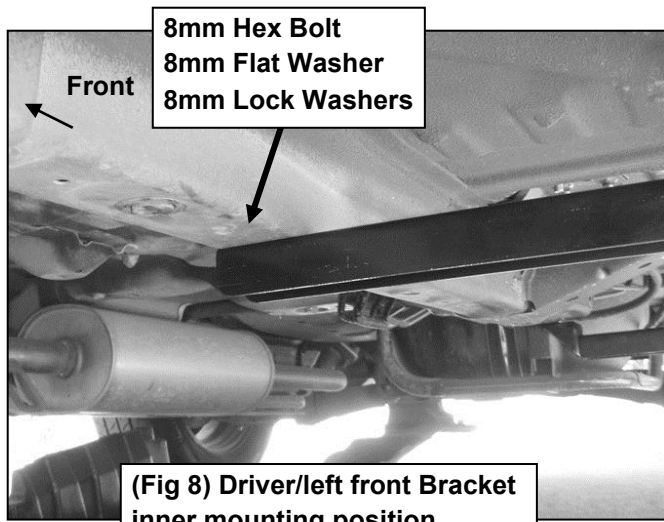

(Fig 8) Driver/left front Bracket inner mounting position

- 8mm Hex Bolts
- 8mm Flat Washers
- 8mm Lock Washers
- 8mm Hex Nuts

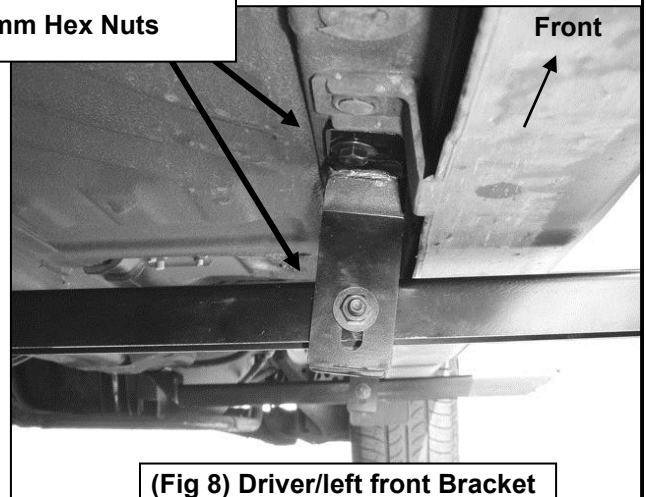

(Fig 8) Driver/left front Bracket outer mounting position

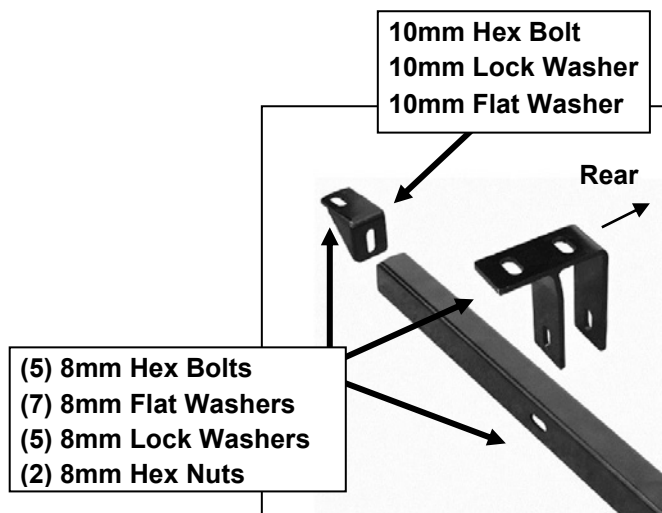

(Fig 9) Driver/left rear Bracket assembly

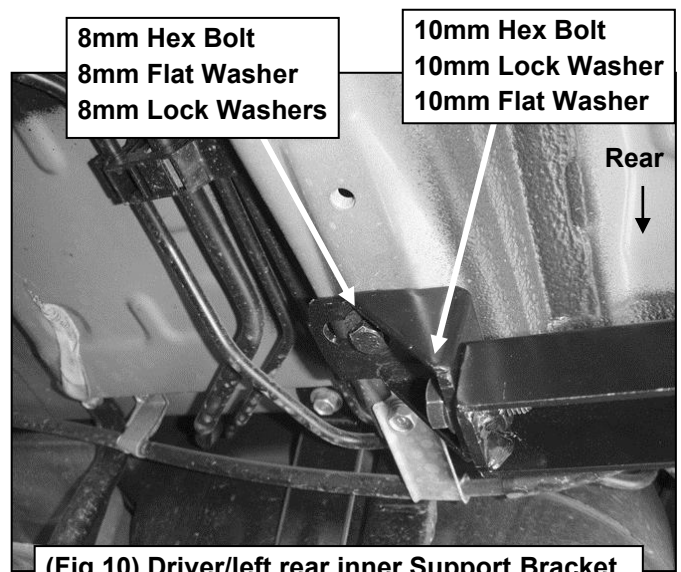

(Fig 10) Driver/left rear inner Support Bracket

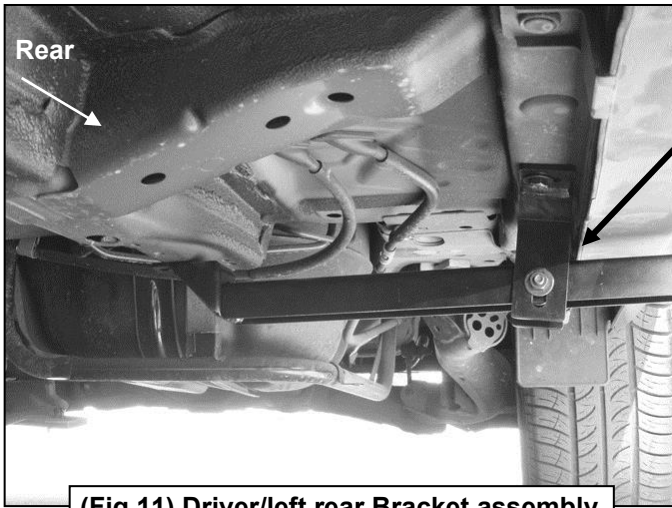

- (2) 8mm Hex Bolts
- (4) 8mm Flat Washers
- (2) 8mm Lock Washers
- (2) 8mm Hex Nuts

(Fig 11) Driver/left rear Bracket assembly

10. Select the driver/left side Running Board. Insert (2) 6mm T-Bolts into each slot and slide them down the channel in the bottom of the Board and into approximate position in line with the Brackets, **(Figure 12)**.

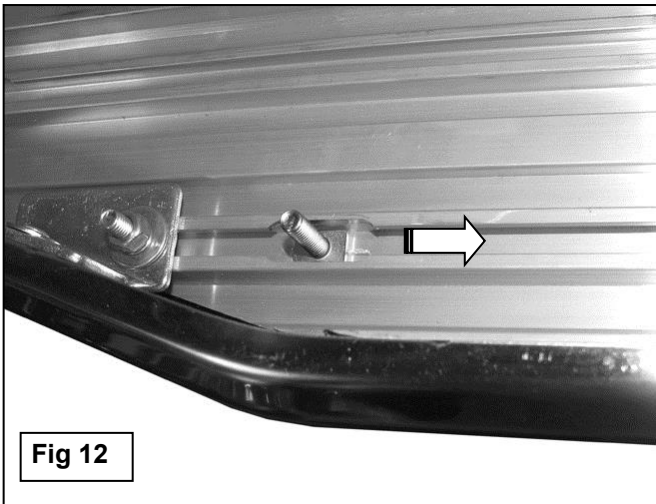

Fig 12

11. Carefully position the Driver/Left Running Board onto the (2) Mounting Brackets. Slide the T-Bolts into position and through the slots in the Brackets, **(Figure 13)**. Attach the Board to the Brackets with (4) 6mm Flat Washers, (4) 6mm Lock washers and (4) 6mm Hex Nuts, **(Figure 14)**. Do not tighten hardware at this time.

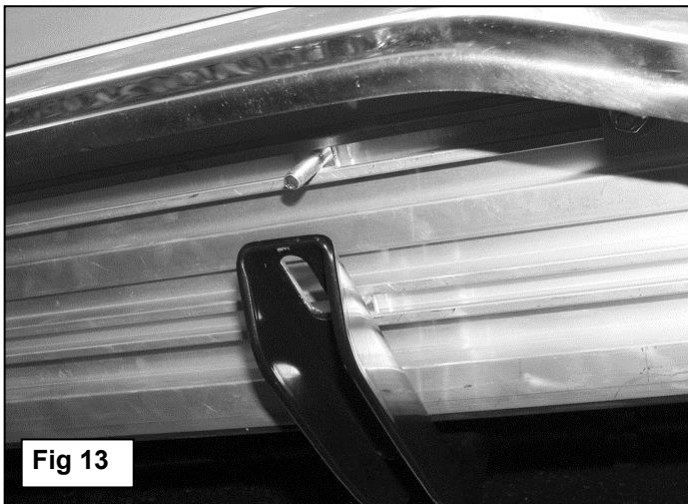

Fig 13

(2) 6mm T-Bolts
(2) 6mm Flat Washers
(2) 6mm Lock Washers
(2) 6mm Hex Nuts

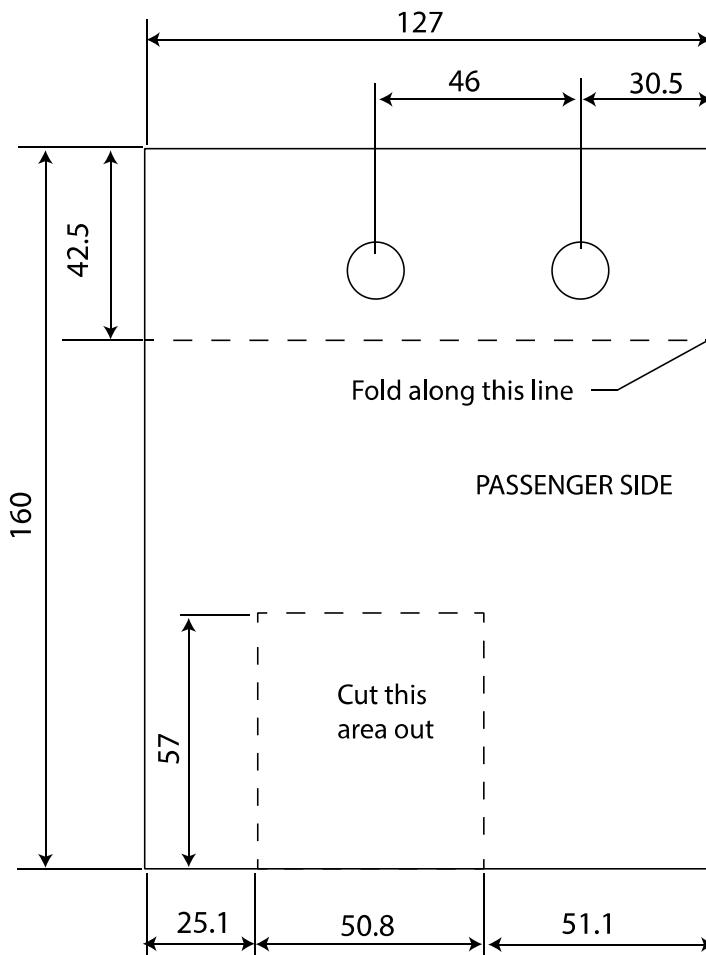
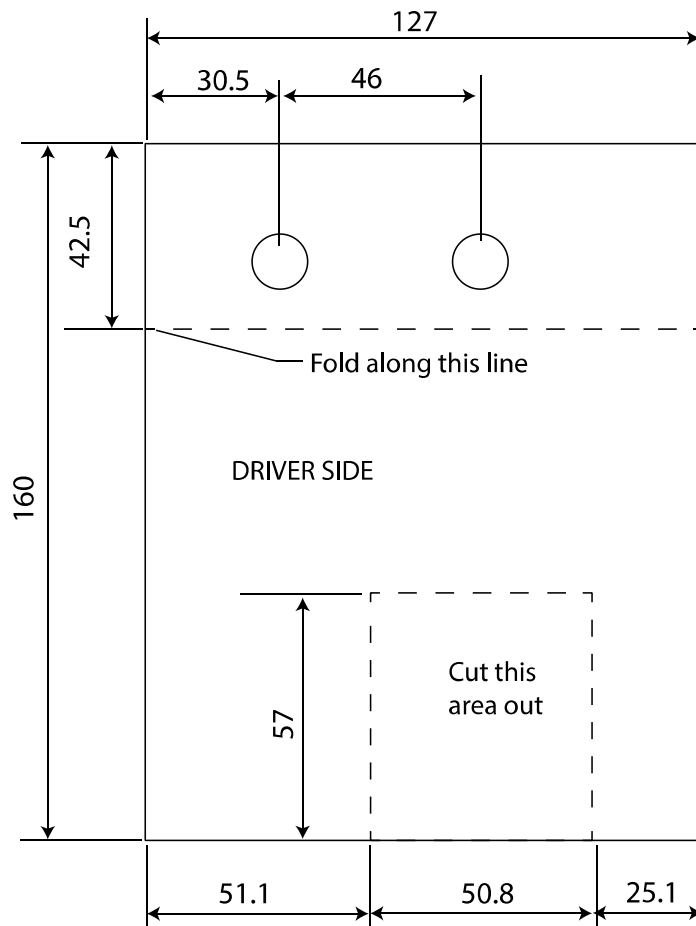

Fig 14

12. Level and adjust the Running Board and tighten all hardware.
13. Leave the plastic cover completely loose and fully tighten the hardware bolting the Brackets to the vehicle. **NOTE:** It may be necessary to remove the Brackets and plastic cover if the cover requires additional cutting. Leave plastic cover loose at this time. Cover will not be reinstalled until after the Running Board has been installed, aligned and then all hardware tightened. Cover must be loose to access inner hardware.
14. Once all Bracket hardware has been completely tightened, reinstall the plastic cover with the factory hardware. **NOTE:** Depending on model year, additional trimming may be required around the Brackets to clear the inside of the plastic cover near the frame channel.
15. Repeat **Steps 2 – 15** for passenger/right side Running Board installation.
16. Do periodic inspections to the installation to make sure that all hardware is secure and tight.



Complete Installation



PRODUCT CARE

- Periodically check the product to ensure all fasteners are tight and components are intact.
- Regular waxing is recommended to protect the finish of the product.
- **Use ONLY Non-Abrasive automotive wax.** Use of any soap, polish or wax that contains an abrasive is detrimental and can scratch the finish leading to corrosion.
- Aluminum polish may be used to polish small scratches and scuffs for **Stainless Steel finish.**
- Mild soap may be used to clean the product for both **Stainless Steel and Black finish.**

FAQ's

1. Hardware's are not of correct size.

In GMC / Chevrolet truck model 2006 & up, customer needs to reuse the factory body bolts to install the bracket. If your vehicle is not GMC / Chevrolet 2006 & up, ensure that holes are not partially covered with any plastic grommet or rust? If it is, remove the plastic grommet & rust from the thread holes & re-try the installation.

2. Mounting Bracket are not getting Installed properly.

In some cases Illustration images shown in Installation manual may not be the exactly same as per actual vehicle images ,also if Driver / Passenger side mounting brackets are very identical in the design, suggest referring Parts Identification guide to avoid fitment issue.

3. Products are thumping / rattling after installation.

Ensure that all required mounting brackets / hardware's are installed & tighten correctly. Suggest using white lithium / regular grease between the metal to metal contact surfaces.

4. Side Bar is not aligning with vehicle / Step Pads are not aligning with vehicle doors.

Side bar may be interchanged or mounting brackets are not installed at the correct position in the vehicle. Refer Parts identification guide.

5. Missing / Excess Hardware.

Recheck hardware count as per the part list.

6. Product not installing properly.

Ensure make model year, cab length and bed size of your vehicle is listed in the application. All installation steps are followed correctly.