



# Replacement Front Bumper

## Part No. FX3017



Fits: 2007-2010

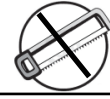
GMC Sierra 2500/3500 HD



ASSISTANCE IS RECOMMENDED.



60-180 min



Cutting Not Required



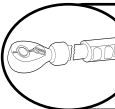
Drilling Not Required



REMOVE CONTENTS FROM BOX. VERIFY ALL PARTS ARE PRESENT.



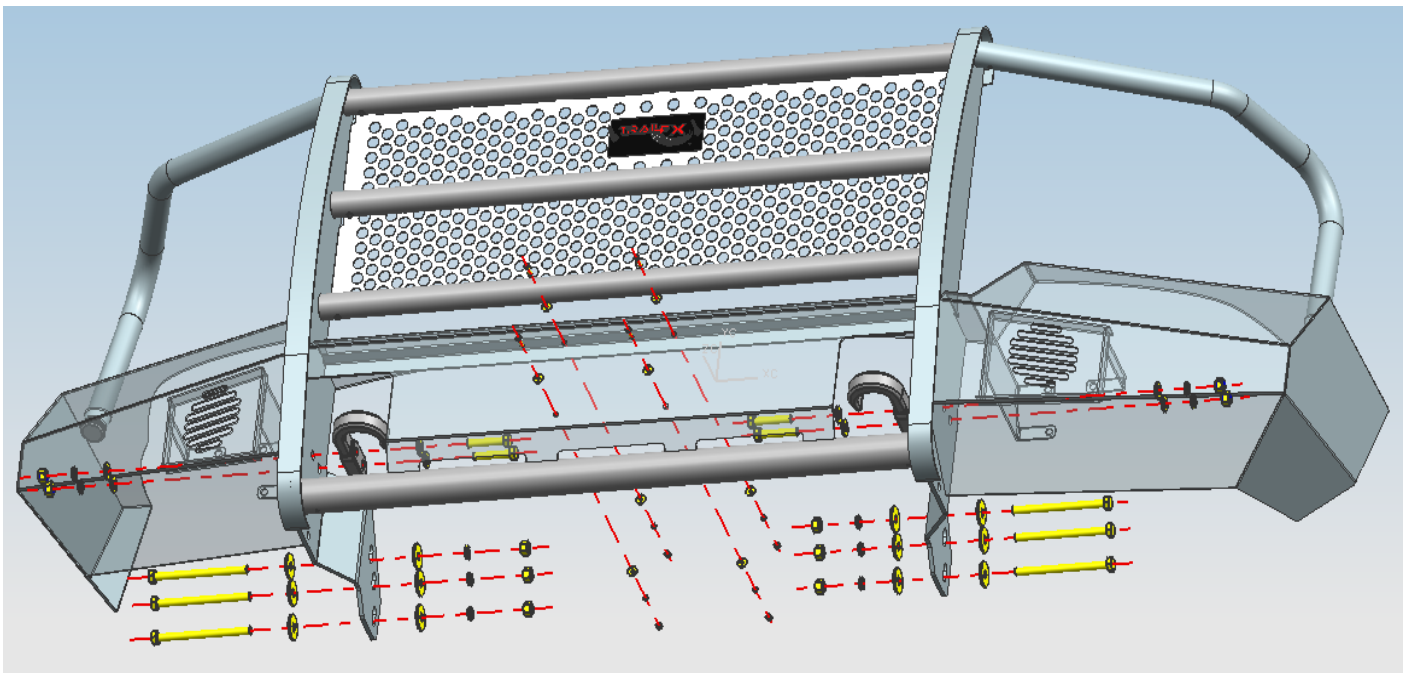
READ INSTRUCTIONS CAREFULLY BEFORE STARTING INSTALLATION.



DO NOT OVER TORQUE. STANDARD OPERATING LOAD FOR TIGHTEN BODY MOUNT NUTS & BOLTS VARIES FROM 45 TO 65 FOOT POUND.

### PARTS LIST:

Qty	Part Description	Qty	Part Description
1	Replacement Bumper	4	12×60mm Hex Bolts
2	Tow Hooks	6	12×150mm Half Thread Hex Bolts
4	5×20mm Phillips Screws	8	12×24×2.5mm Flat Washers
8	5x15x1.2mm Flat Washers	12	12×37×3mm Flat Washers
4	5mm Lock Washers	10	12mm Lock Washers
4	5mm Hex Nuts	10	12mm Hex Nuts



## INSTALLATION PROCEDURE

**BUMPER IS HEAVY, ASSISTANCE IS HIGHLY RECOMMENDED TO AVOID POSSIBLE INJURY OR DAMAGE TO THE VEHICLE.**

### Vehicle Preparation

1. Disconnect the factory fog lamp connectors (If Applicable), zip tie harness to frame.
2. Open the Hood and remove the 8 dart clips holding the plastic radiator valance (**Fig 1**).



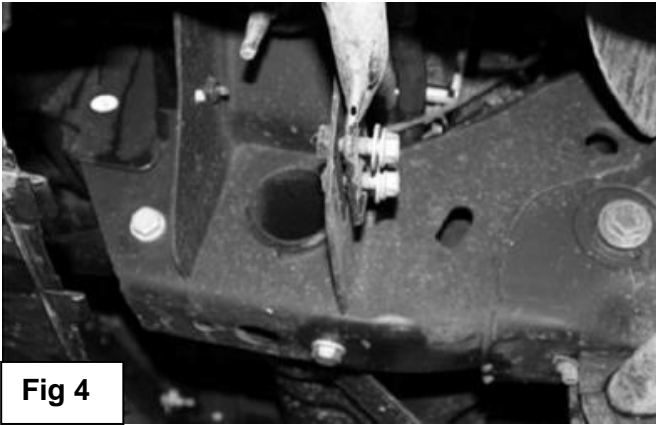
3. Remove the two 7mm screws from the plastic piece from inside the wheel well. Repeat on other side (**Fig 2**).



4. Reaching behind the grill use needle nose pliers or a falt bladed screwdriver to pop loose all clips holding the painted bumper section to the grill.
5. Remove the Painted Bumper section from the front of the truck (**Fig 3**).



6. Remove bolts and swing outer bumper support tubes down and out of the way, using a 15mm socket. Two Bolts per side. (Fig 4).



**Fig 4**

7. Remove the dart clips holding the rubber valance between the frame and the bumper.
8. Remove 21mm nuts(2 Per Side) from the bolt strips holding the bumper brackets to the frame.

**NOTE: SUPPORT BUMPER BEFORE REMOVING BOLT STRIPS (Fig 5)!**

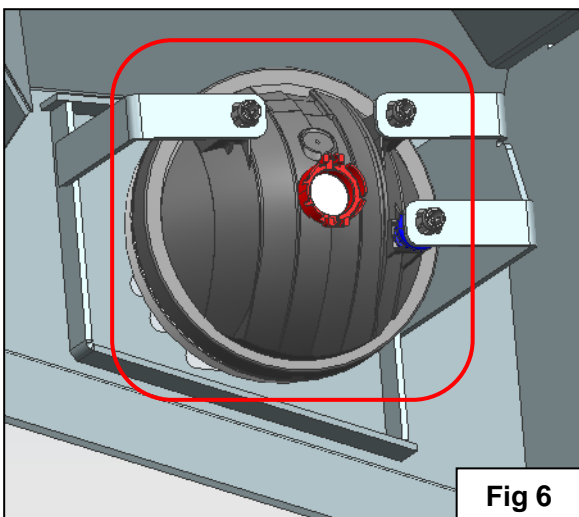


**Fig 5**

9. With the bumper supported remove the bolts strip holding the bumper to the frame.
10. Pull outward slightly at the fender wells and remove from the front.
11. With Bumper removed from the truck, remove the 18mm bolts attaching the Factory Tow Hooks to the frame. Remove the tow hooks.

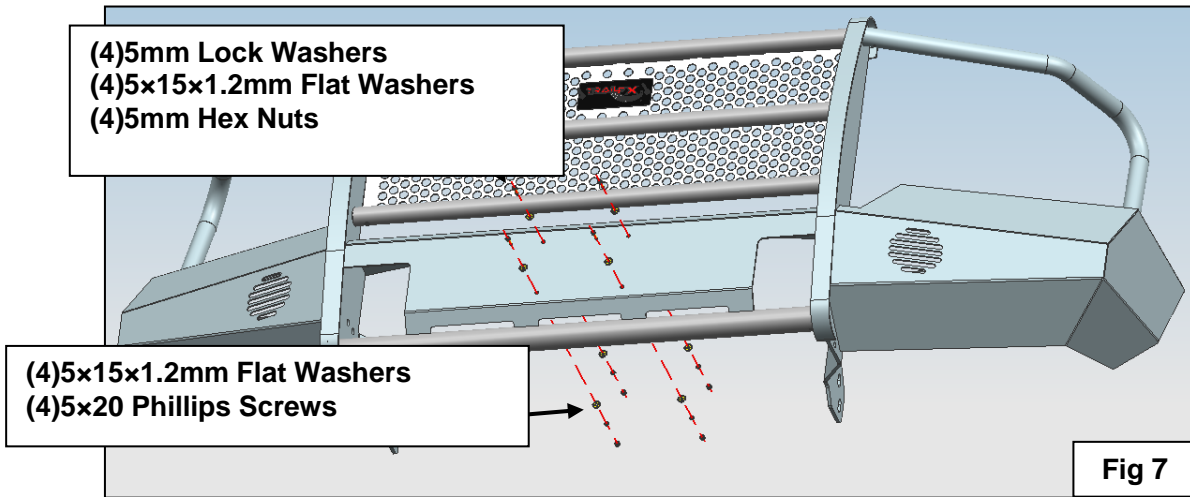
### **Bumper Installation**

1. Remove the fog light from the vehicle. Use the OEM screws and nut plates to fasten the fog light to the bumper (Fig 6).

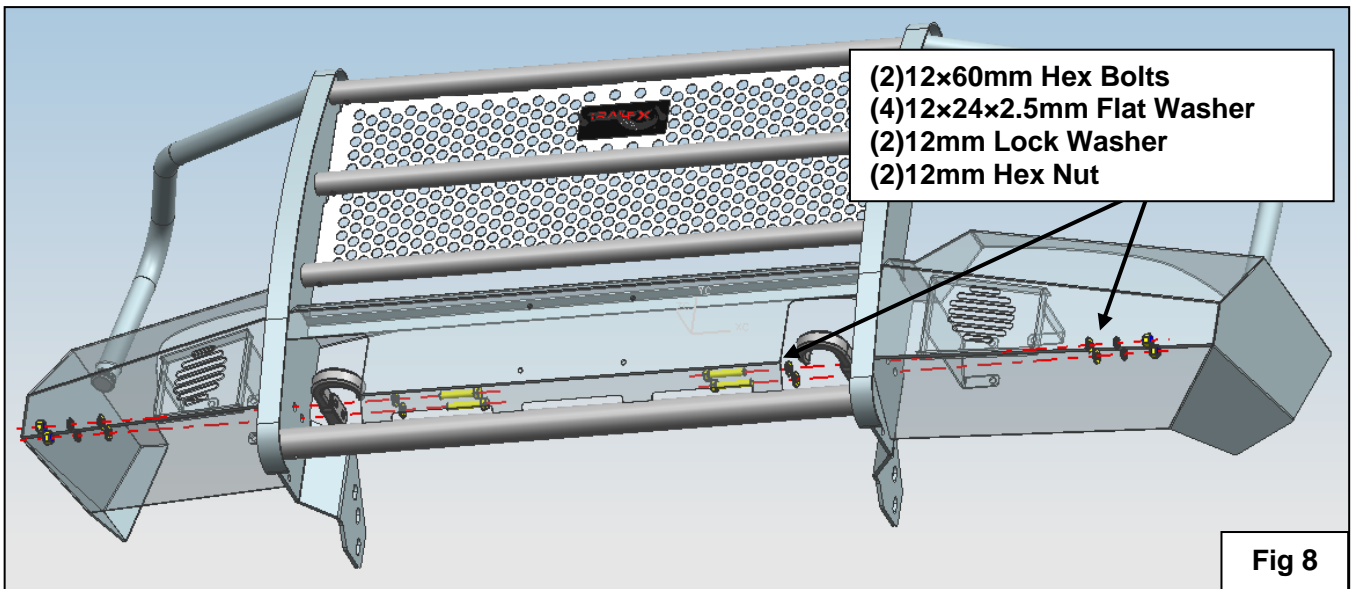


**Fig 6**

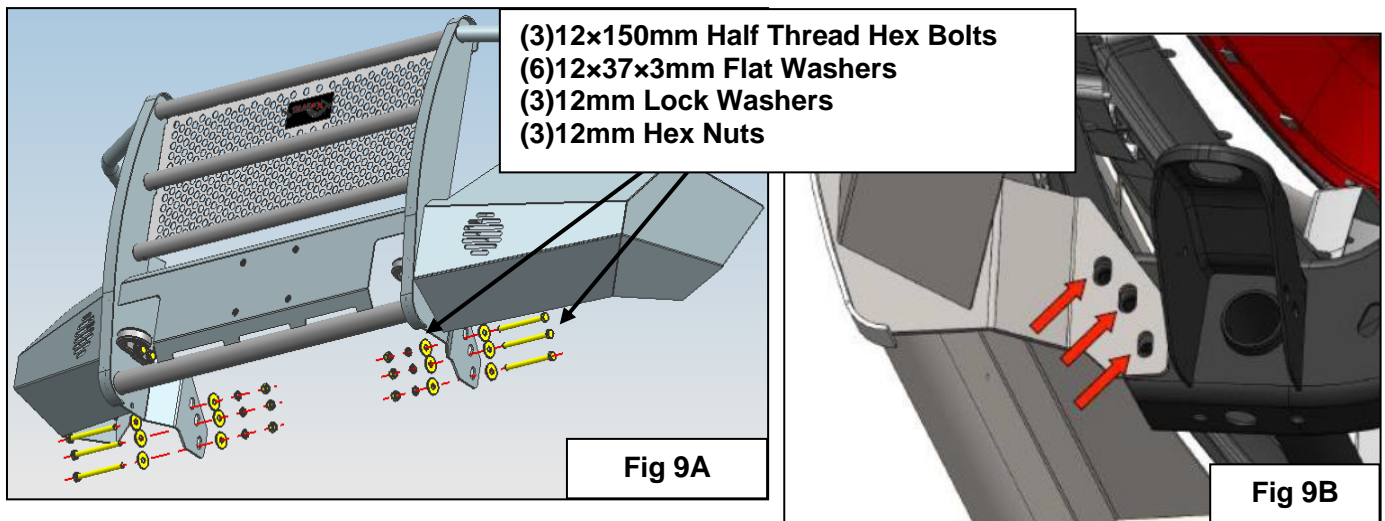
2. Attach the license plate to the Replacement Bumper (Fig 7). Fasten the license plate with the hardware.



3. Fasten the provided Tow Hooks to the Bumper with the hardware (Fig 8).



4. Attach the Bumper to the frame. Fasten the Bumper with the hardware (Fig 9A & 9B).



5. Reinstall the factory wiring harness to the fog light.
6. Level and adjust the bumper, make sure that all hardware is secure and tight.
7. Installation is finished, pick up all tools.