



Replacement Front Bumper

Part No. FX3016



Fits: 2011-2014

GMC Sierra 2500/3500 HD



ASSISTANCE IS RECOMMENDED.



60-180 min

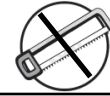

Cutting Not Required



Drilling Not Required



REMOVE CONTENTS FROM BOX. VERIFY ALL PARTS ARE PRESENT.



READ INSTRUCTIONS CAREFULLY BEFORE STARTING INSTALLATION.

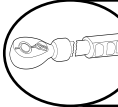

DO NOT OVER TORQUE. STANDARD OPERATING LOAD FOR TIGHTEN BODY MOUNT NUTS & BOLTS VARIES FROM 45 TO 65 FOOT POUND.

PARTS LIST:

Qty	Part Description	Qty	Part Description
1	Replacement Front Bumper	6	12x120mm Hex Bolts
4	5x20mm Philips Screws	12	12x37x3mm Lock Washers
8	5x15x1.2mm Lock Washers	6	12mm Lock Washers
4	5mm Lock Washers	6	12mm Hex Nuts
4	5mm Hex Nuts		

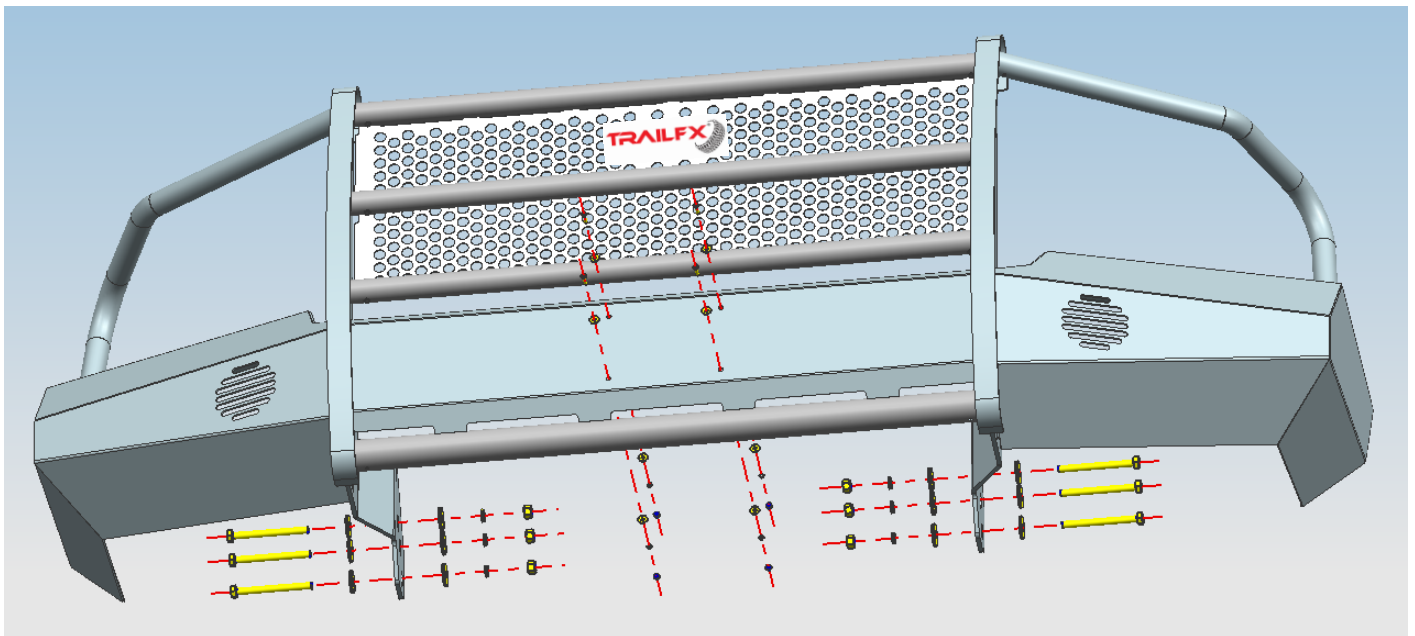

INSTALLATION PROCEDURE

BUMPER IS HEAVY, ASSISTANCE IS HIGHLY RECOMMENDED TO AVOID POSSIBLE INJURY OR DAMAGE TO THE VEHICLE.

Vehicle Preparation

1. Take off lower fender cover by removing two screws and two nuts per side (the second nut didn't show in the picture) with a 10mm socket (**Fig 1A & 1B**).

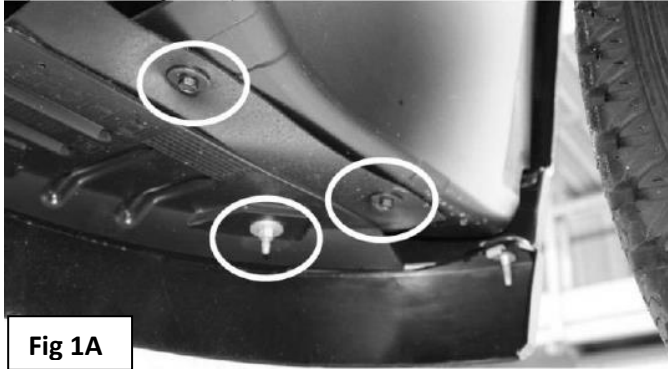

2. Reaching from the bottom of the bumper, remove the two screws per side connecting the plastic bumper valance to the sheet metal fender with a 10mm socket and extension. It may be helpful to loosen the inner fender mounting screws to allow better access.
3. Remove the two screws per side in the fender well holding the bumper valance to the mounting bracket with a 7mm socket.
4. Starting at the fender, carefully pull the valance outward working it around to the center of truck (**Fig 2A & 2B**).

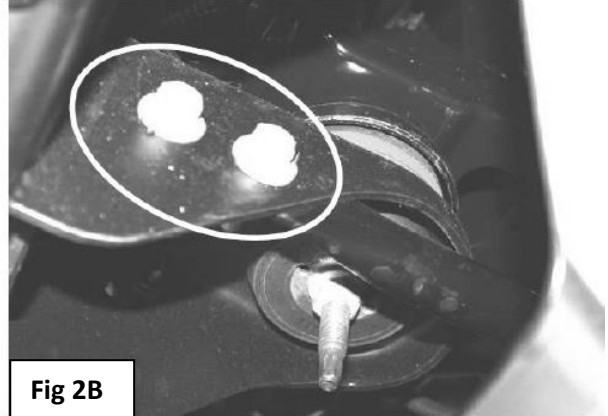

5. With the bumper valance removed, unclip the splash mat from the three plastic push fasteners attaching it to the body.
6. Disconnect the wiring harness from both OEM fog lights,
7. Remove the two screws connecting the outer bumper support bar to the body mount bracket (15mm). Loosen the screw connecting the outer bumper support bar to the bumper (15mm), allowing it to rotate downward.
8. Remove the two fasteners per tow hook (18mm) and pull tow hook out from the front of the truck.
9. Remove the two main bumper bracket nuts per side (**Fig 3A & 3B**).

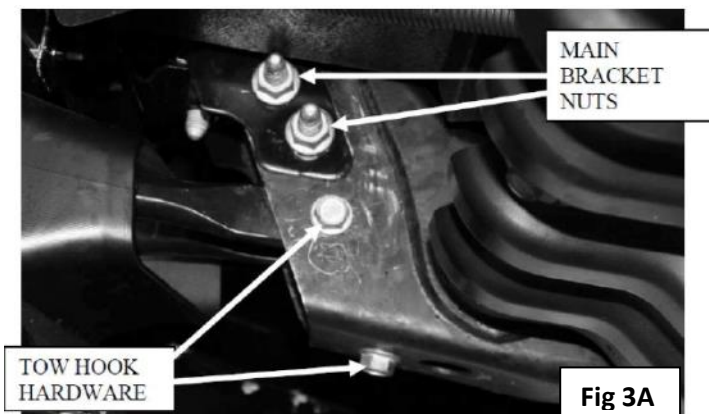

DO NOT REMOVE THE BOLT STRIPS WITHOUT SUPPORTING THE BUMPER.

10. With the weight of the bumper supported, remove the stud plates and pull the bumper forward away from the truck.
11. Remove the remaining plastic support brackets for the bumper valance using a 10mm socket.
12. The truck is now ready for TrailFX bumper installation.

Bumper Installation

1. Remove the fog light from the vehicle, install the fog light on the light mounting bracket of the bumper with the factory hardware.

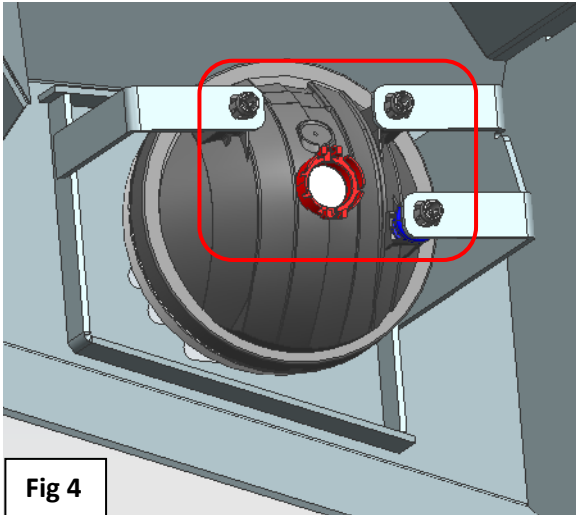
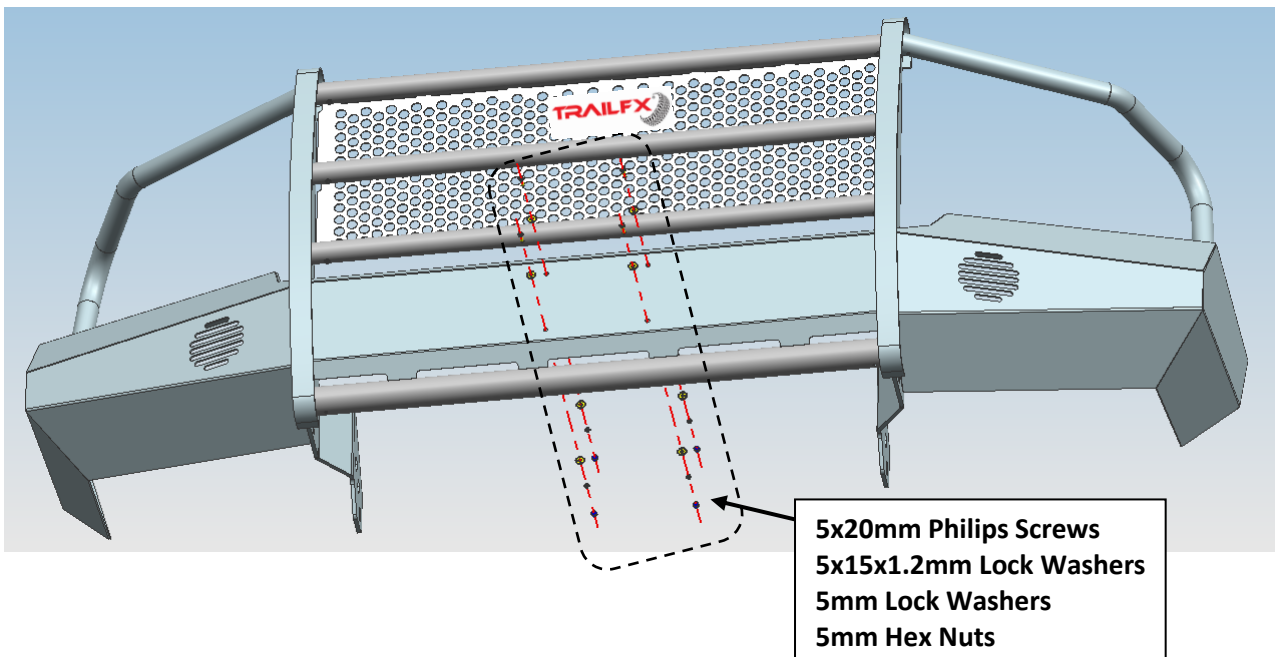
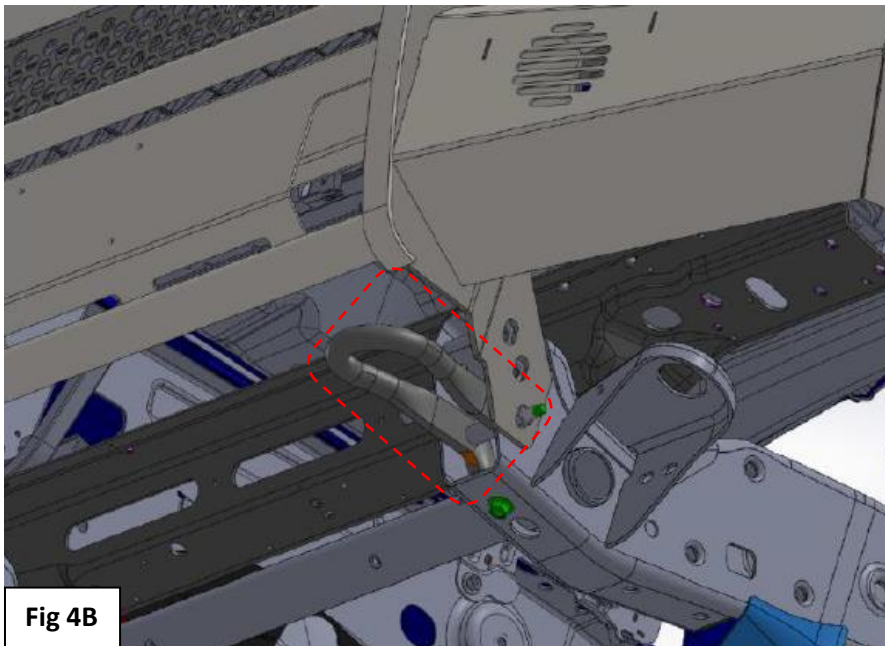
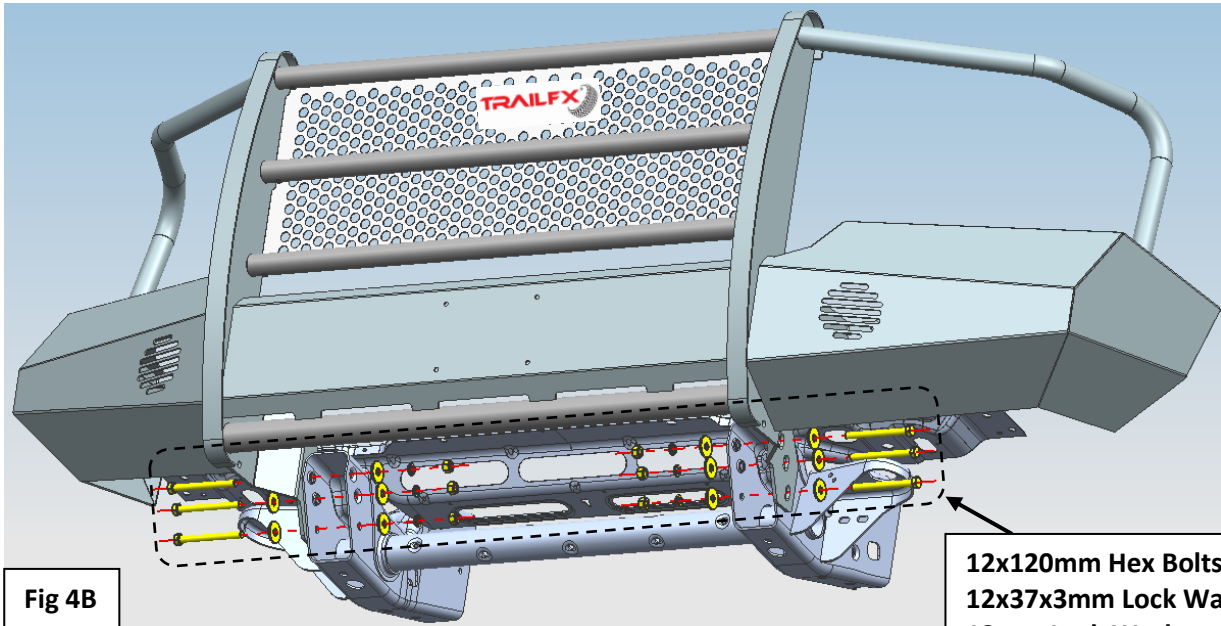

Fig 4

2. Install the license plate on the replacement front bumper with the hardware (**Fig 3**)



3. Install replacement front bumper on the frame with the hardware, then install the OEM tow hooks (Fig 4A & 4B).



4. Check the gap between the bumper and the vehicle.
5. Connect the fog light and the wiring, make sure the light can be lightened.
6. Installation is finished, pick up all tools.

PRODUCT CARE

- Periodically check the product to ensure all fasteners are tight and components are intact.
- Regular waxing is recommended to protect the finish of the product.
- **Use ONLY Non-Abrasive automotive wax.** Use of any soap, polish or wax that contains an abrasive is detrimental and can scratch the finish leading to corrosion.
- Aluminum polish may be used to polish small scratches and scuffs for **Stainless Steel finish.**
- Mild soap may be used to clean the product for both **Stainless Steel and Black finish.**

FAQ's

1. Hardware's are not of correct size.

In GMC / Chevrolet truck model 2006 & up, customer needs to reuse the factory body bolts to install the bracket. If your vehicle is not GMC / Chevrolet 2006 & up, ensure that holes are not partially covered with any plastic grommet or rust? If it is, remove the plastic grommet & rust from the thread holes & re-try the installation.

2. Mounting Bracket are not getting Installed properly.

In some cases Illustration images shown in Installation manual may not be the exactly same as per actual vehicle images ,also if Driver / Passenger side mounting brackets are very identical in the design, suggest referring Parts Identification guide to avoid fitment issue.

3. Products are thumping / rattling after installation.

Ensure that all required mounting brackets / hardware's are installed & tighten correctly. Suggest using white lithium / regular grease between the metal to metal contact surfaces.

4. Side Bar is not aligning with vehicle / Step Pads are not aligning with vehicle doors.

Side bar may be interchanged or mounting brackets are not installed at the correct position in the vehicle. Refer Parts identification guide.

5. Missing / Excess Hardware.

Recheck hardware count as per the part list.

6. Product not installing properly.

Ensure make model year, cab length and bed size of your vehicle is listed in the application. All installation steps are followed correctly.

Check out these other TrailFX Products!!



Keystone Automotive Operations Inc. (KAO) warrants this product to be free of defects in material and workmanship at the time of purchase by the original retail consumer. KAO disclaims any other warranties, express or implied, including the warranty of fitness for a particular purpose or an intended use. If the product is found to be defective, KAO may replace or repair the product at our option, when the product is returned prepaid, with proof of purchase. Alteration to, improper installation, or misuse of this product voids the warranty. KAO's liability is limited to repair or replacement of products found to be defective, and specifically excludes liability for any incidental or consequential loss or damage.