



Replacement Bumper

Part No. FX3003



Fits: 1999 - 2004 Ford Superduty F250 / F350 / F450 / F550 HD



60-120 min

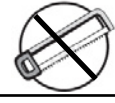

Cutting Not Required



Drilling Not Required



REMOVE CONTENTS FROM BOX. VERIFY ALL PARTS ARE PRESENT.



READ INSTRUCTIONS CAREFULLY BEFORE STARTING INSTALLATION.

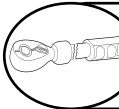

DO NOT OVER TORQUE. STANDARD OPERATING LOAD FOR TIGHTEN BODY MOUNT NUTS & BOLTS VARIES FROM 45 TO 65 FOOT POUND.

PARTS LIST:

| Qty | Part Description | Qty | Part Description |
|-----|--------------------|-----|------------------|
| 1 | Replacement Bumper | 1 | Hardware Kit |

Tools Required

| | |
|------------------------------|-----------------------|
| Socket Wrench With Extension | 3/4" Socket |
| 18mm Socket | 3/4" Open End Wrench |
| 7/32" Socket | 7/16" Open End Wrench |
| Phillips Screwdriver | 3/8" Open End Wrench |
| Hammer | |

INSTALLATION PROCEDURE:

1. Vehicle Preparation

1. Disconnect factory fog lamp connectors, zip tie harness to frame.
2. Remove fasteners holding OEM bumper to chassis.
3. Remove factory bumper assembly.

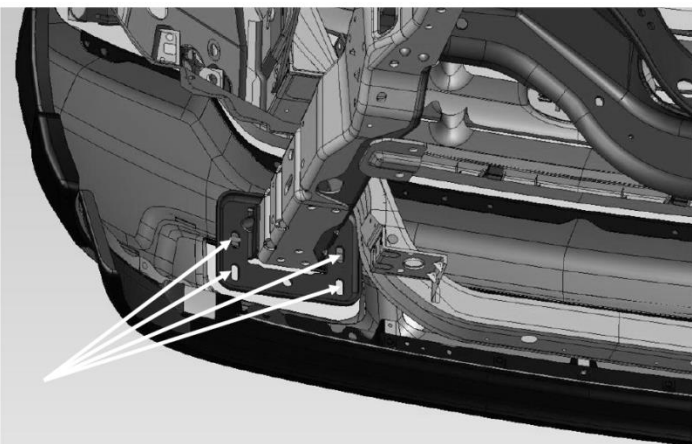

2. Bumper Installation

1. Remove the Bumper from the shipping carton. Lay all items out on a blanket to prevent damage to the powder coating.
2. **OPTIONAL:** If you wish to retain the stock fog lamps, remove the lights from the stock bumper and reinstall using OEM plastic push-rivets and lower adjuster screw and spring in the provided brackets behind the protective mesh.

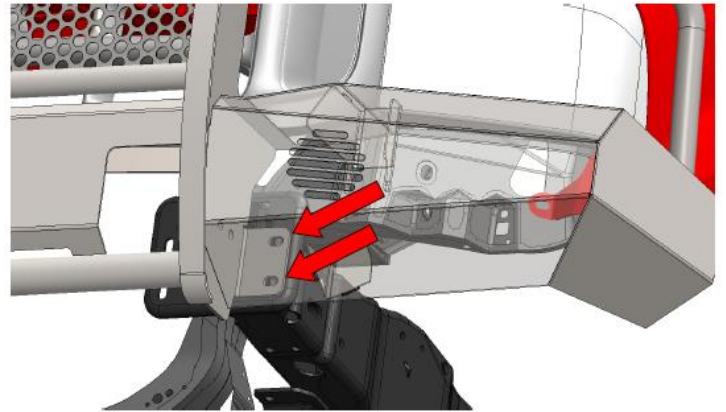
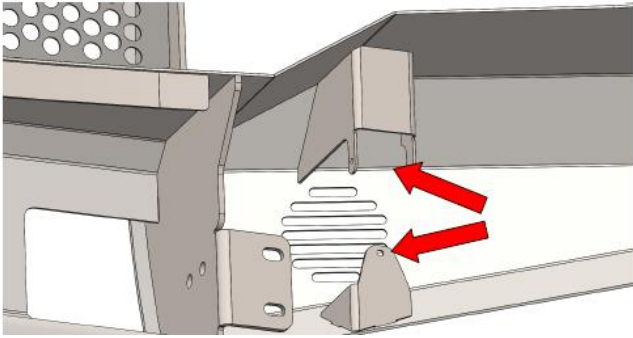

3. Lift bumper and align mounting slots with the OEM bumper mounting holes in the frame. Reinstall factory hardware through mounts. Do not yet fully tighten.

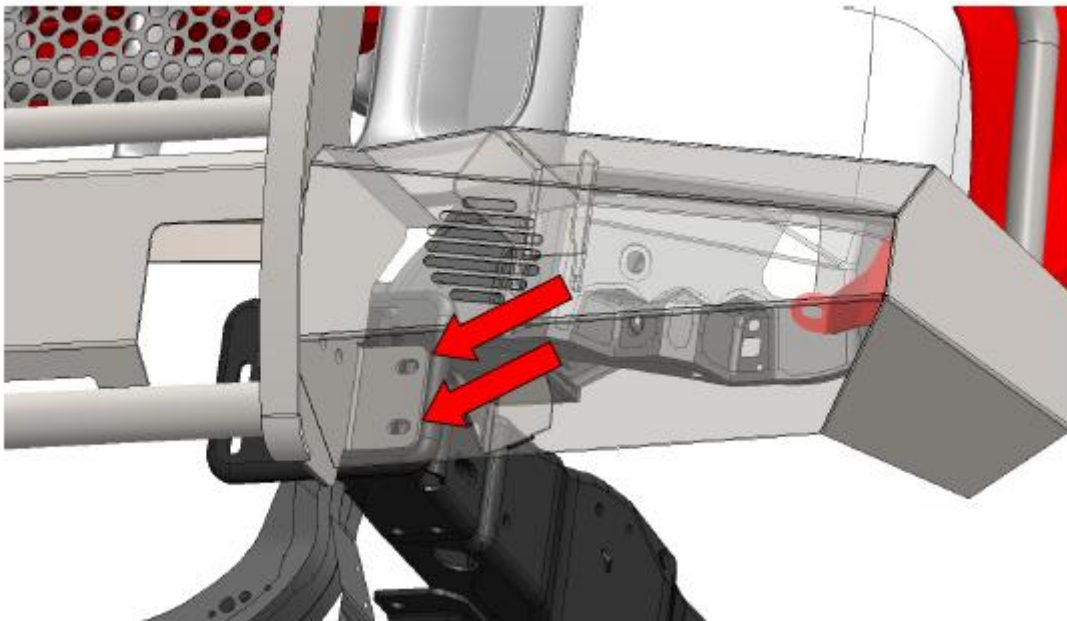

4. Adjust the bumper to achieve good visual alignment.
5. Tighten all fasteners once alignment is satisfactory.
6. **Optional:** install the tow hooks to the insides of the bumper uprights using the provided hardware.

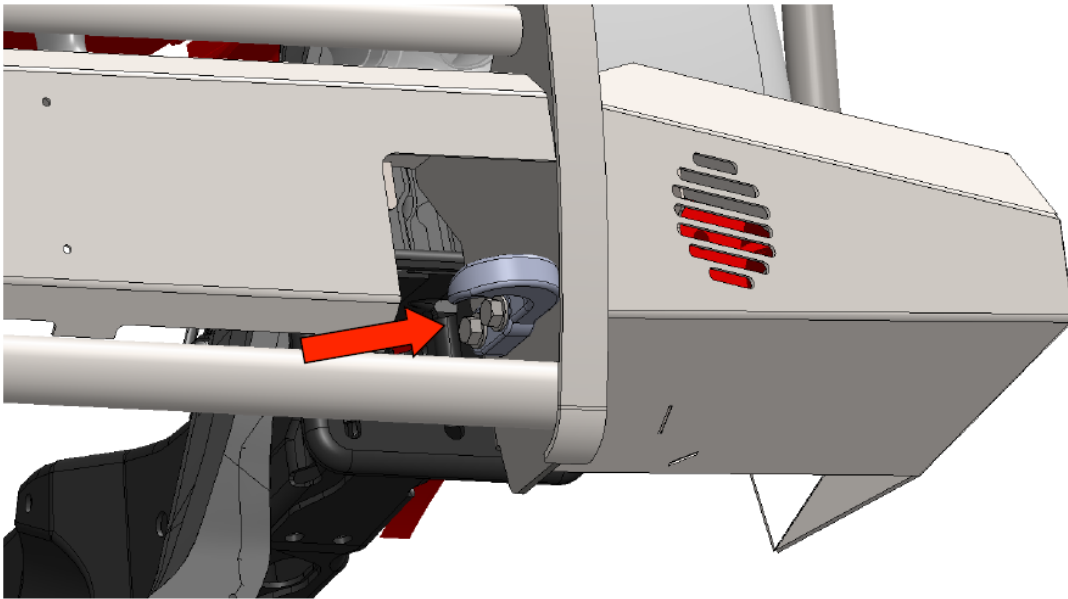

7. Check for good overall alignment of the bumper and tighten all fasteners.
8. **OPTIONAL:** Trim inner-fender liners to match bumper if desired.



PRODUCT CARE

- Periodically check the product to ensure all fasteners are tight and components are intact.
- Regular waxing is recommended to protect the finish of the product.
- **Use ONLY Non-Abrasive automotive wax.** Use of any soap, polish or wax that contains an abrasive is detrimental and can scratch the finish leading to corrosion.
- Aluminum polish may be used to polish small scratches and scuffs for **Stainless Steel finish.**
- Mild soap may be used to clean the product for both **Stainless Steel and Black finish.**

FAQ's

1. Hardware's are not of correct size.

In GMC / Chevrolet truck model 2006 & up, customer needs to reuse the factory body bolts to install the bracket. If your vehicle is not GMC / Chevrolet 2006 & up, ensure that holes are not partially covered with any plastic grommet or rust? If it is, remove the plastic grommet & rust from the thread holes & re-try the installation.

2. Mounting Bracket are not getting Installed properly.

In some cases Illustration images shown in Installation manual may not be the exactly same as per actual vehicle images ,also if Driver / Passenger side mounting brackets are very identical in the design, suggest referring Parts Identification guide to avoid fitment issue.

3. Products are thumping / rattling after installation.

Ensure that all required mounting brackets / hardware's are installed & tighten correctly. Suggest using white lithium / regular grease between the metal to metal contact surfaces.

4. Side Bar is not aligning with vehicle / Step Pads are not aligning with vehicle doors.

Side bar may be interchanged or mounting brackets are not installed at the correct position in the vehicle. Refer Parts identification guide.

5. Missing / Excess Hardware.

Recheck hardware count as per the part list.

6. Product not installing properly.

Ensure make model year, cab length and bed size of your vehicle is listed in the application. All installation steps are followed correctly.