

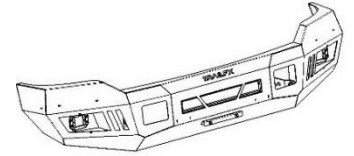

# HD Front Bumper Without Winch

Part No. FHDNW002TI



Fits: **2010 - Current Dodge Ram 2500/3500**



ASSISTANCE IS RECOMMENDED.



REMOVE CONTENTS FROM BOX. VERIFY ALL PARTS ARE PRESENT.



READ INSTRUCTIONS CAREFULLY BEFORE STARTING INSTALLATION.

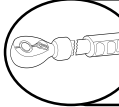

DO NOT OVER TORQUE. STANDARD OPERATING LOAD FOR TIGHTEN BODY MOUNT NUTS & BOLTS VARIES FROM **45 TO 65** FOOT POUND.



60-180 min

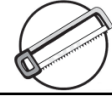

Cutting Required



Drilling Not Required

## PARTS LIST:

Qty	Part Description	Qty	Part Description
1	HD Front Bumper Assembly	10	200mm Nylon Wire Ties
1	Driver/left side Frame Mounting Bracket	6	Retaining Ring
1	Passenger/right side Frame Mounting Bracket	6	Centering Foam Washers
1	License Plate Bracket	3	Dodge Wiring Harnesses
2	License Plastic Plugs	2	8-1.25mm x 25mm Hex Bolts
1	Driver/left side LED Light "L" Bracket	2	8-1.25mm x 16mm Hex Bolts
1	Passenger/right side LED Light "L" Bracket	6	8mm x 24mm x 2mm Flat Washers
8	12-1.75mm x 50mm Hex Bolts	4	8mm Lock Washers
6	12-1.75mm x 40mm Hex Bolts	2	8-1.25mm Hex Nuts
12	12mm x 37mm x 3mm Flat Washers	2	6-1.0mm x 20mm Button Head Bolts
16	12mm x 32mm x 3mm Flat Washers	4	6mm x 18mm x 1.6mm Flat Washers
8	12mm Lock Washers	2	6mm Nylon Lock Nuts
8	12-1.75mm Hex Nuts	1	4mm Allen Wrench
6	12mm Nylon Lock Nuts	12	4-0.75mm x 10mm Button Head Bolts
6	Sensor Hole Plugs	1	2.5mm Allen Wrench
1	Sensor Cover Kit		

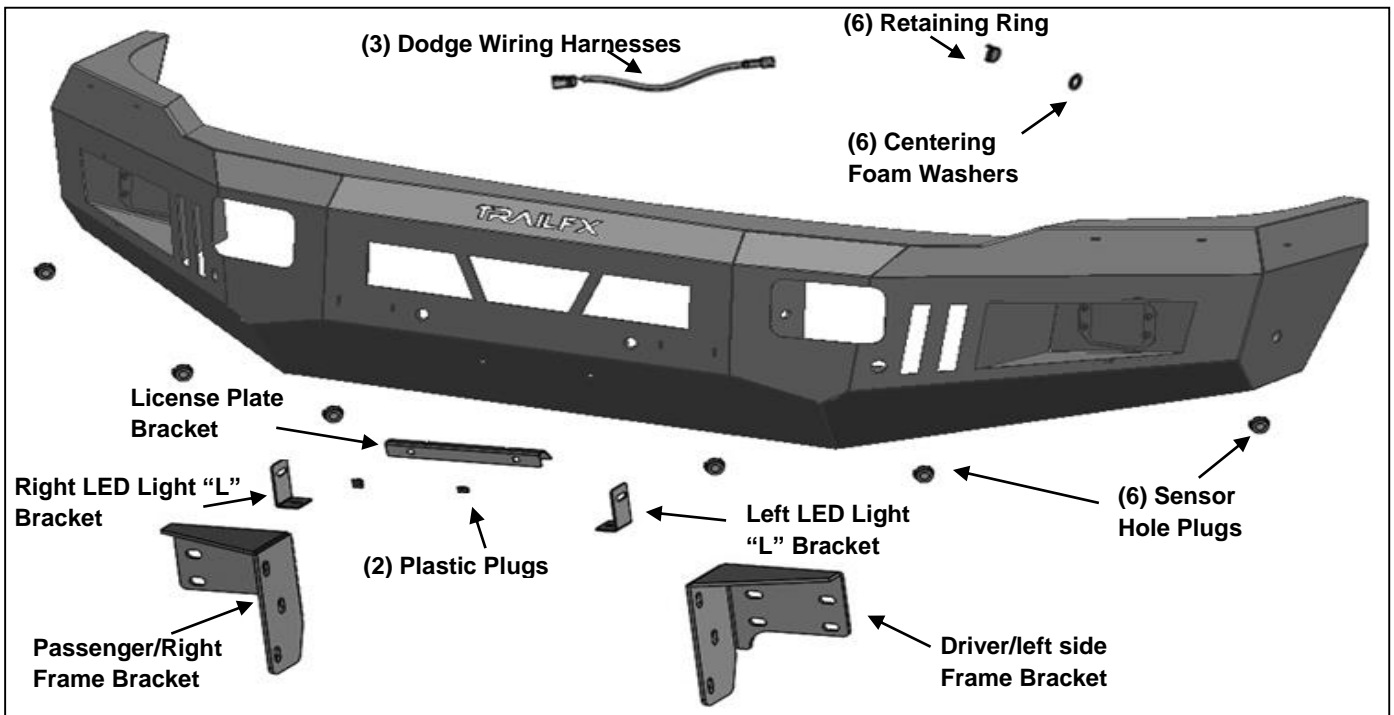

## INSTALLATION PROCEDURE:

**BUMPER IS HEAVY, ASSISTANCE IS HIGHLY RECOMMENDED TO AVOID POSSIBLE INJURY OR DAMAGE TO THE VEHICLE. CUTTING MAY BE REQUIRED.**

1. Remove the license plate and bracket. On models with factory fog lights and/or sensors, unplug wiring harness, **(Figure 1)**. Release the harness from the clips attached to the back of the bumper and move harness away from bumper.
2. Next, open hood and remove the plastic cover between the top of the grille and the top of the radiator. Carefully remove the grill assembly, **(Figures 2 & 3)**.
3. Place blocks or jack stands under the front bumper to support it during mounting bolt removal. Once the bumper has been safely supported, remove the hex nuts attaching each bumper bracket to the end of the frame, **(Figure 4)**. **WARNING!** Assistance is required to hold the bumper in place during hardware removal to prevent the bumper from falling. Slide the bumper assembly off of the tow hooks.
4. Next, remove the tow hooks from the ends of the frame, **(Figures 5 & 6)**.
5. Select the driver/left side Frame Mounting Bracket. Attach the Bracket to the end of the frame with (4) 12mm x 50mm Hex Bolts, (8) 12mm x 32mm Flat Washers, (4) 12mm Lock Washers and (4) 12mm Hex Nuts, **(Figure 7)**. Leave hardware loose. Repeat this Step to install the passenger Frame Bracket.
6. **Optional Center LED light installation**, (sold separately). **NOTE:** Light must be installed in Bumper before Bumper Assembly is attached to the Brackets.
  - a. Select the L/R "L" Brackets, **(Figure 8)**. **NOTE:** "L" Brackets are offset for universal fitment for most LED bar style lights. Attach the LED light assembly to the "L" Brackets with the included (2) 8mm x 16mm Hex Bolts, (2) 8mm Lock Washers and (2) 8mm Flat Washers, **(Figure 8)**. Do not fully tighten hardware at this time. **NOTE:** "L" Brackets may require modification for hardware larger than 8mm or use brackets supplied with light if possible.
  - b. Attach the light and brackets to the top of the (2) tabs on the back of the Bumper with the included 8mm x 25mm Hex Bolts, (4) 8mm Flat Washers, (2) 8mm Lock Washers and (2) 8mm Hex Nuts, **(Figure 8)**. Adjust light position and tighten hardware.
  - c. Follow light manufacturer's instructions to wire the light to the vehicle's electrical system once Bumper has been fully installed.
7. **LED light installation at ends of bumper** (sold separately).
  - a. Insert light into opening and up to mounting slots. Check for clearance between front and back of light. If necessary, remove the screens from the back of the openings, **(Figure 9)**.
  - b. Follow the light manufacturer's instructions to attach each light to slot in the top of the light opening. **IMPORTANT:** On two light systems, attach the flood light to the outer slot and the spot light to the inner slot.
  - c. Repeat the above steps for passenger side light installation.
  - d. Follow light manufacturer's instructions to properly wire the light to the vehicle electrical system.
8. **NOTE:** Sensors, (if equipped), must be installed in Bumper before Bumper is attached to Brackets.

### **Models without bumper sensors:**

- a. Select the included (6) Rubber Plugs.
- b. From behind bumper, push plugs into sensor mounting holes.

### **Models with bumper mounted sensors:**

- a. Remove sensors from back of OE Bumper.
- b. Trim off the plastic tabs on the sensor to make sure the sensor fits snug inside the sensor sleeve. Remove the factory sealing washer from the sensor. Attach (1) Centering Foam Washer onto the front of the sensor, **(Figure 10)**.
- c. Push the sensor in from the back of the Bumper until it is flush with the sensor sleeve. Push (1) Retaining Ring into the sensor sleeve to secure the sensor in place, **(Figure 10)**.
- d. Repeat **Steps 8b & 8c** for all six sensors.
- e. Starting on the driver side, run the OE sensor wire harness through the bumper cutouts. Connect the first three driver side sensors to the OE sensor wire harness.
- f. Use the provided wire harness extensions to connect the remaining three passenger side sensors to the OE sensor wire harness.

- g. Use the provided Wire Ties to secure the Wiring Harnesses to the back of the Bumper.
9. If front license plate is required, attach the License Plate Bracket to the holes in the bumper with the included (2) 6mm x 20mm Button Head Bolts, (4) 6mm Flat Washers and (2) 6mm Nylon Lock Nuts, **(Figure 11)**. Insert (2) Plastic Plugs into the square holes in the Bracket. Reuse the factory screws to attach the license plate to the plastic plugs.
  10. With assistance, position the LD1 Bumper Assembly up to the insides of the Frame Brackets. Temporarily support the weight of the Bumper. **WARNING:** To avoid possible injury or damage to the vehicle, do not proceed until the Bumper is fully and safely supported.
  11. Attach the Bumper to the inside of the Frame Brackets with (6) 12mm x 40mm Hex Bolts, (12) 12mm x 37mm Flat Washers and (6) 12mm Nylon Lock Nuts, **(Figures 12 & 13)**. Do not fully tighten hardware.
  12. Reattach the main wiring harness to the bumper sensors, if equipped.
  13. Level and adjust the bumper and fully tighten all hardware.
  14. Trim off the underlined section of the plastic wheel well liner for a clean finish, optional. See **Figure 14**.
  15. Do periodic inspections to the installation to make sure that all hardware is secure and tight.

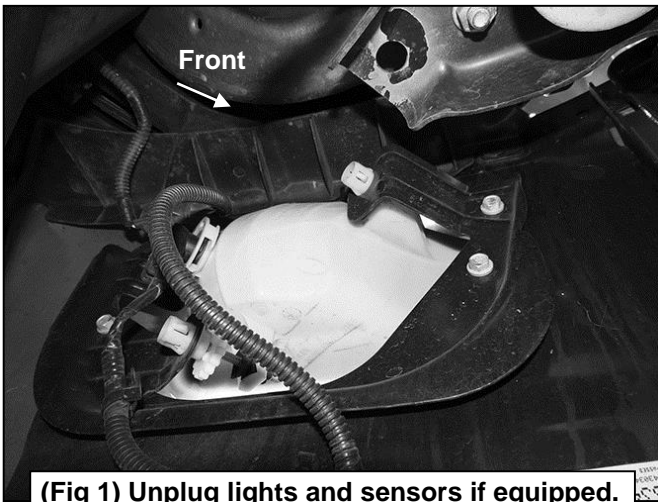

**(Fig 1) Unplug lights and sensors if equipped. Unplug harness to bumper and move harness**

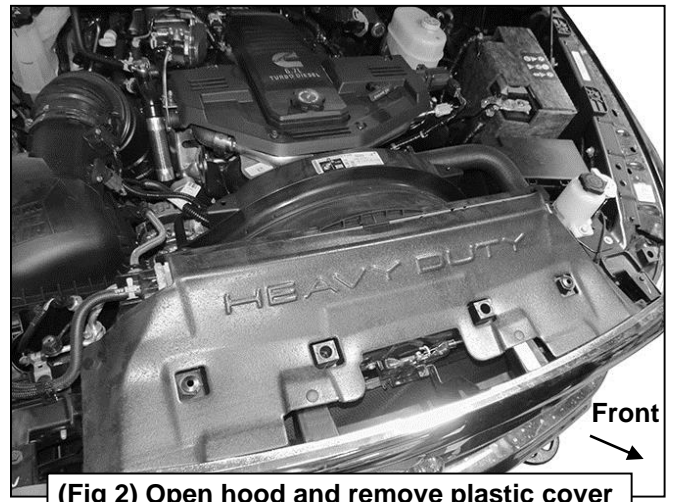

**(Fig 2) Open hood and remove plastic cover**

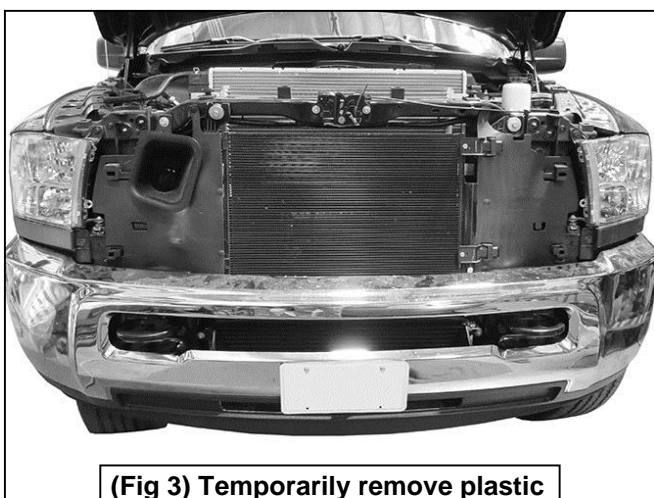

**(Fig 3) Temporarily remove plastic grille to access top bumper bolts**

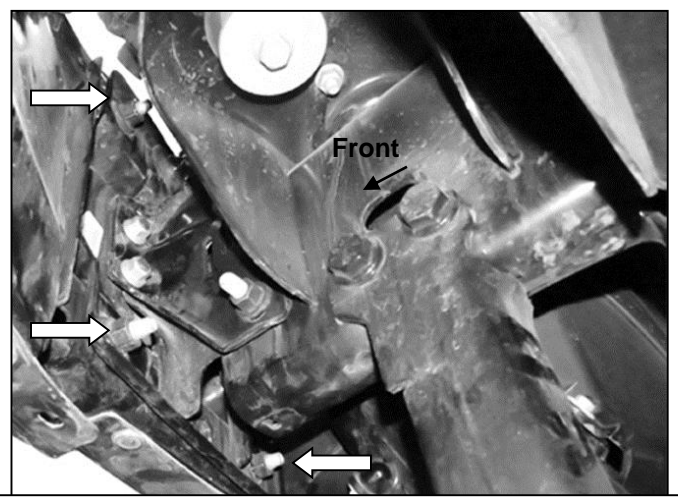

**(Fig 4) Remove hex nuts from bumper bolts (arrows). Bumper bracket pictured from below/behind bumper**

**WARNING!** Do not remove bumper bolts unless the bumper is properly supported on blocks or stands or the bumper may fall.

Driver Side Installation Pictured

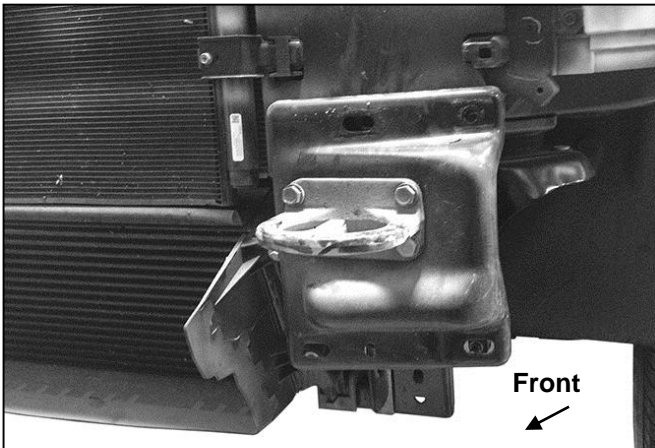

(Fig 5) Remove tow hook (Driver side pictured)

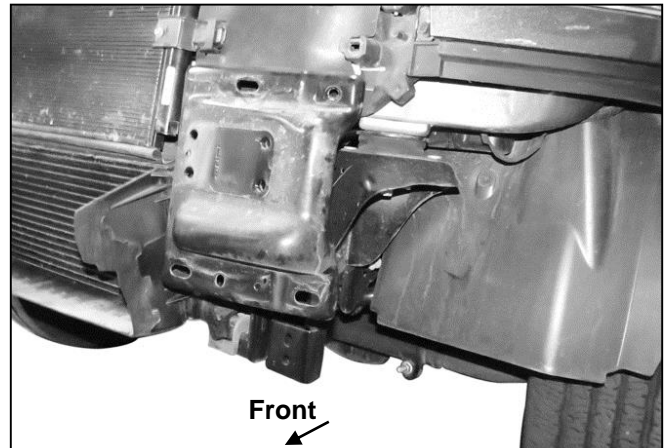

(Fig 6) Tow hook removed from driver side

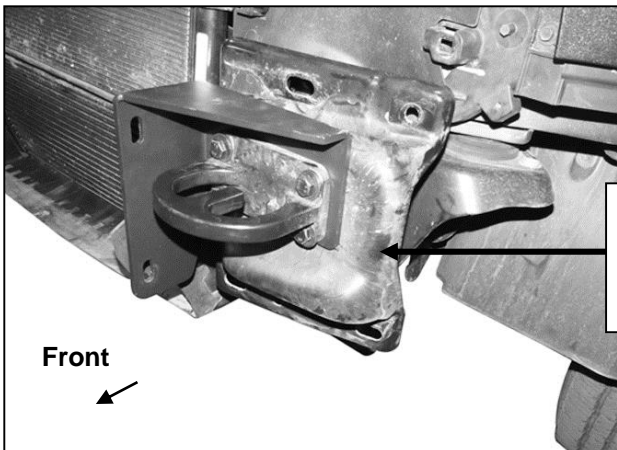

(Fig 7) Attach driver/left Frame Bracket to end of frame (Pictured with tow hook)

- (4) 12mm x 50mm Hex Bolts
- (8) 12mm x 32mm Flat Washers
- (4) 12mm Lock Washers
- (4) 12mm Hex Nuts

- (2) 8mm x 16mm Hex Bolts
- (2) 8mm Lock Washers
- (2) 8mm Flat Washers

- (2) 8mm x 25mm Hex Bolts
- (4) 8mm Flat Washers
- (2) 8mm Lock Washers
- (2) 8mm Hex Nuts

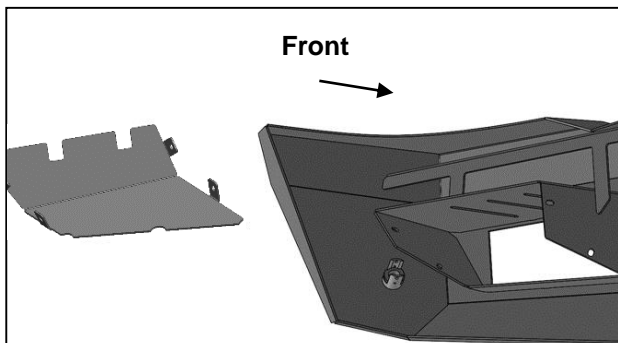

(Fig 9) Remove screens if necessary for clearance/access to outer light mounts

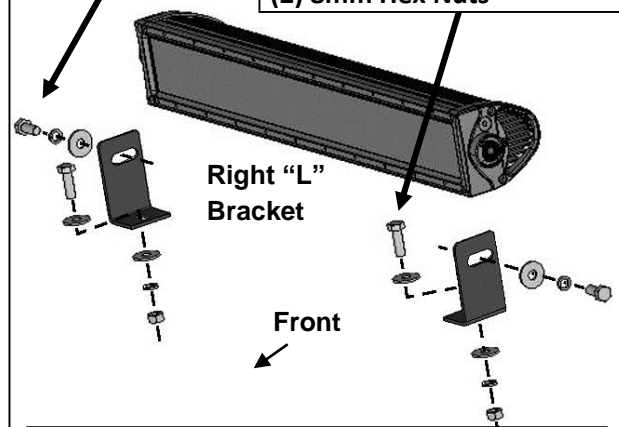

(Fig 8) Example of center light installation

Driver Side Installation Pictured

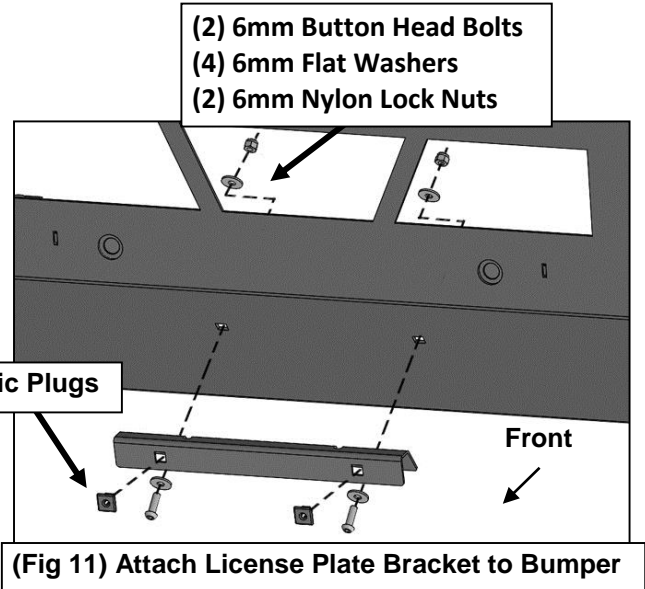
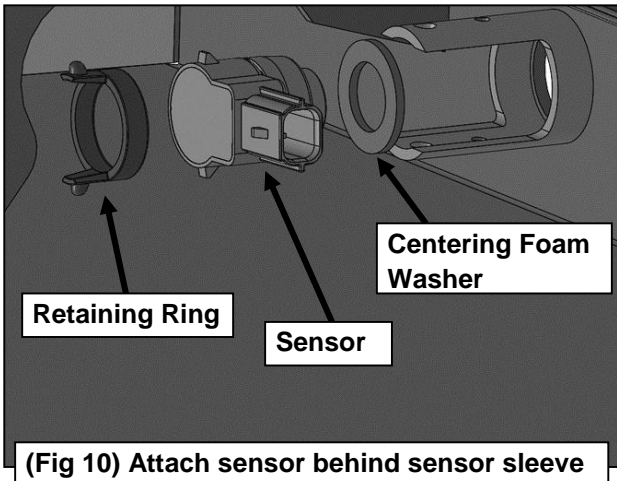

**WARNING!** Do not crawl under bumper unless the bumper is properly supported on blocks or stands or the bumper may fall.

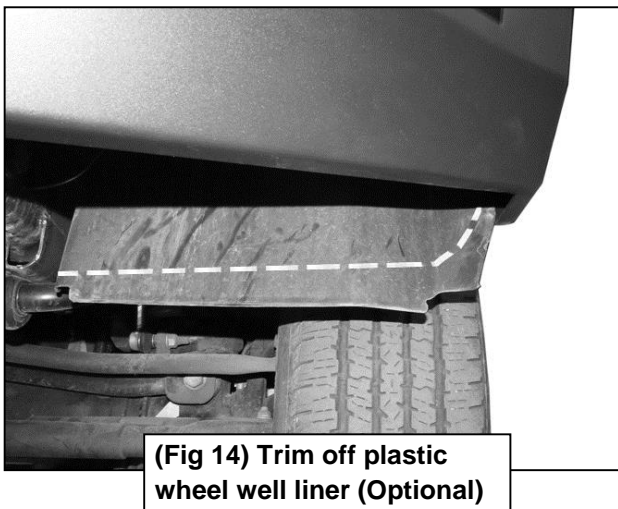
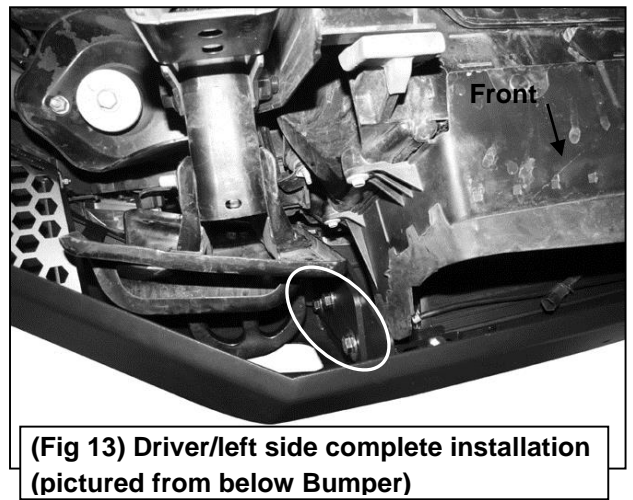
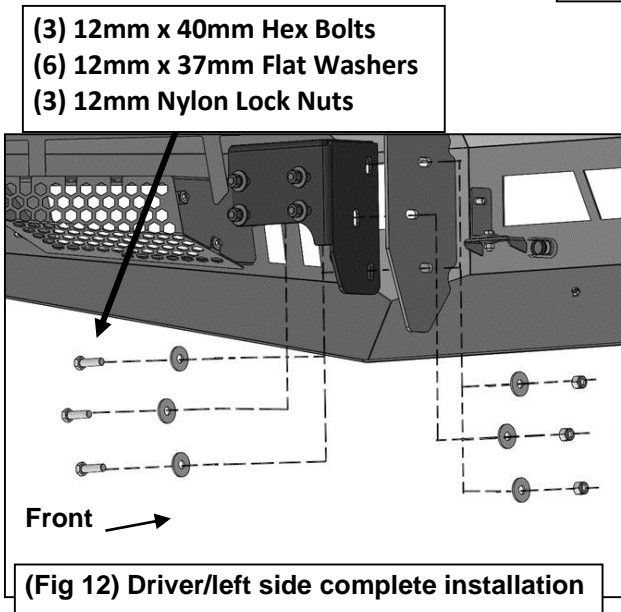

## PRODUCT CARE

- Periodically check the product to ensure all fasteners are tight and components are intact.
- Regular waxing is recommended to protect the finish of the product.
- **Use ONLY Non-Abrasive automotive wax.** Use of any soap, polish or wax that contains an abrasive is detrimental and can scratch the finish leading to corrosion.
- Aluminum polish may be used to polish small scratches and scuffs for **Stainless Steel finish.**
- Mild soap may be used to clean the product for both **Stainless Steel and Black finish.**

## FAQ's

**1. Hardware's are not of correct size.**

*In GMC / Chevrolet truck model 2006 & up, customer needs to reuse the factory body bolts to install the bracket. If your vehicle is not GMC / Chevrolet 2006 & up, ensure that holes are not partially covered with any plastic grommet or rust? If it is, remove the plastic grommet & rust from the thread holes & re-try the installation.*

**2. Mounting Bracket are not getting Installed properly.**

*In some cases Illustration images shown in Installation manual may not be the exactly same as per actual vehicle images ,also if Driver / Passenger side mounting brackets are very identical in the design, suggest referring Parts Identification guide to avoid fitment issue.*

**3. Products are thumping / rattling after installation.**

*Ensure that all required mounting brackets / hardware's are installed & tighten correctly. Suggest using white lithium / regular grease between the metal to metal contact surfaces.*

**4. Side Bar is not aligning with vehicle / Step Pads are not aligning with vehicle doors.**

*Side bar may be interchanged or mounting brackets are not installed at the correct position in the vehicle. Refer Parts identification guide.*

**5. Missing / Excess Hardware.**

*Recheck hardware count as per the part list.*

**6. Product not installing properly.**

*Ensure make model year, cab length and bed size of your vehicle is listed in the application. All installation steps are followed correctly.*

## Check out these other TrailFX Products!!



Keystone Automotive Operations Inc. (KAO) warrants this product to be free of defects in material and workmanship at the time of purchase by the original retail consumer. KAO disclaims any other warranties, express or implied, including the warranty of fitness for a particular purpose or an intended use. If the product is found to be defective, KAO may replace or repair the product at our option, when the product is returned prepaid, with proof of purchase. Alteration to, improper installation, or misuse of this product voids the warranty. KAO's liability is limited to repair or replacement of products found to be defective, and specifically excludes liability for any incidental or consequential loss or damage.