



# LADDER RACK

## Part No. FCLR007W



**Fits: 2014+ City Express, 2015+ Ram Promaster City, 2016+ Metris  
2010+ NV200, 2012+ NV, 2002+ TRANSIT Connect, 2013+ TRANSIT**



VANS WITHOUT GUTTER



REMOVE CONTENTS FROM BOX. VERIFY ALL PARTS ARE PRESENT.



READ INSTRUCTIONS CAREFULLY BEFORE STARTING INSTALLATION.

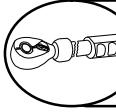

DO NOT OVER TORQUE. STANDARD OPERATING LOAD FOR TIGHTEN BODY MOUNT NUTS & BOLTS VARIES FROM **45** TO **65** FOOT POUND.



60-180 min

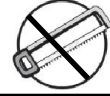

Cutting Not Required



Drilling Not Required

### PARTS LIST for 1 Bars Model:

Qty	Part Description	Qty	Part Description
1	Cross Members	3	10mm Nylon Lock Nuts
1	Ladder Brackets	4	8mm U-Clips
2	Roof Brackets	2	8mm x 30mm Hex Bolts
2	Tube Spacers	4	8mm x 20mm Hex Bolts
2	120mm x 33mm x 6mm Rubber Spacers	2	8mm x 24mm x 2mm Flat Washers
2	128mm x 51mm x 5mm Plates	4	8mm x 16mm x 1.6mm Flat Washers
2	125mm x 51mm x 3mm Rubber Pads	4	8mm Lock Washers
2	8mm x 45mm x 3mm Rubber Washers	2	8mm Nylon Lock Nuts
2	10mm x 70mm Hex Bolts	4	6mm x 20mm Hex Bolts
1	10mm x 25mm Hex Bolts	4	6mm x 12mm x 1.6mm Flat Washers
6	10mm x 20mm x 2mm Flat Washers	4	6mm Lock Washers

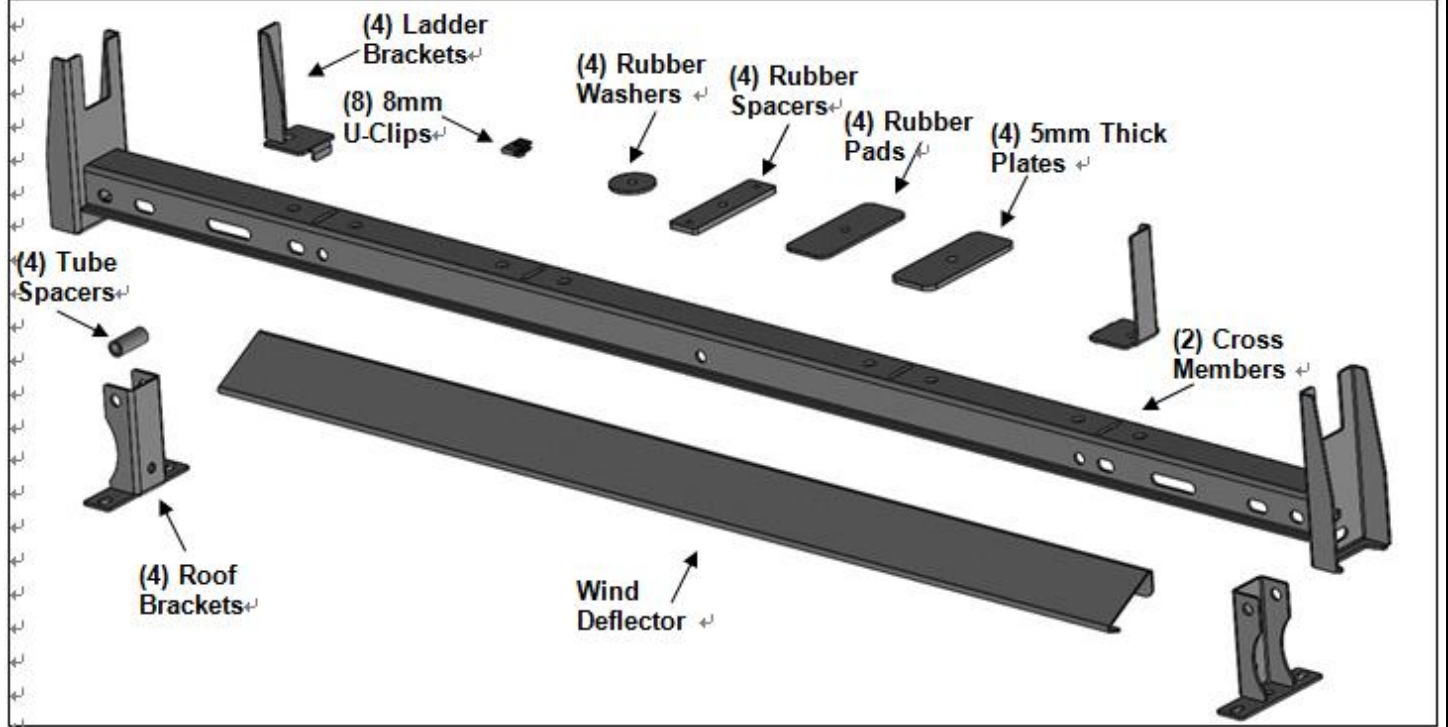

## PROCEDURE:

1. **REMOVE CONTENTS FROM BOX. VERIFY ALL PARTS ARE PRESENT. READ INSTRUCTIONS AND WARNING ON PAGE 3 CAREFULLY BEFORE STARTING INSTALLATION. ASSISTANCE IS RECOMMENDED.**
2. Select (1) Cross Member and the Wind Deflector. Align the (3) slots on the Wind Deflector with the (2) inner slots and (1) center hole on the front face of the Cross Member, **(Figure 1)**. Use the provided (3) 10mm x 25mm Hex Bolts, (6) 10mm x 20mm Flat Washers and (3) 10mm Nylon Lock Nuts to attach the Wind Deflector to the Cross Member, **(Figure 2)**.
3. Next, select (1) Ladder Bracket. Slide the tab on the Bracket into the rectangular opening on the top face of the Cross Member. Use (1) 10mm x 25mm Hex Bolt, (2) 10mm x 20mm Flat Washers and (1) 10mm Nylon Lock Nut to attach the Bracket to the top of the Cross Member, **(Figure 3)**.
4. Select (1) Roof Bracket and (1) Tube Spacer. Depending on make and model of vehicle, determine the correct mounting slots for the Roof Bracket on the Cross Member, **(Figure 4)**. Slide and align the Tube Spacer into the Roof Bracket. Next, slide the assembly into the bottom of the Cross Member and align with the appropriate slots. Use (1) 10mm x 70mm Hex Bolt, (2) 10mm x 20mm Flat Washers and (1) 10mm Nylon Lock Nut to secure the Roof Bracket and Tube Spacer to the Cross Member, **(Figure 5)**. **NOTE:** When installed properly, the open end on the Roof Bracket will face outward. Repeat this Step to install (1) Roof Bracket on the other side of the Cross Member.
5. Repeat **Steps 3 & 4** to attach (1) Ladder Bracket and (2) Roof Brackets to each remaining Cross Member.
6. Determine the desired mounting location on the roof of the vehicle and remove any plastic plugs, if equipped, **(Figures 6 & 7)**. With assistance, place the Cross Member assemblies onto the desired mounting location on the vehicle. **Depending on the make and model of the vehicle**, determine the correct procedure to install the Cross Member assemblies onto the roof of the vehicle:

### Promaster City

- a. Place and align (1) Rubber Spacer between the bottom of the Roof Bracket and the threaded inserts on the roof.
- b. Use (2) 6mm x 20mm Hex Bolts, (2) 6mm Lock Washers and (2) 6mm Flat Washers to attach the Roof Bracket to the top of the roof, **(Figure 8)**.
- c. Repeat the above Steps for the remaining (5) mounting locations on the roof.

### Transit Connect

- a. Place and align (1) Rubber Spacer between the bottom of the Roof Bracket and the mounting hole on the roof.
- b. Insert (1) 8mm x 30mm Hex Bolt and (1) 8mm x 16mm Flat Washer in through the center hole on the Roof Bracket, Rubber Spacer and through the mounting hole on the roof. From the inside of the roof use the provided (1) Rubber Washer, (1) 8mm x 24mm Flat Washer and (1) 8mm Nylon Lock Nut to secure the Roof Bracket to the roof, **(Figure 9)**.
- c. Repeat the above Steps for the remaining (5) mounting locations on the roof.

### **NV200 & City Express**

- a. Place and align (1) Rubber Washer between the bottom of the Roof Bracket and the threaded insert on the roof.
- b. Use (1) 8mm x 30mm Hex Bolt, (1) 8mm Lock Washer and (1) 8mm x 16mm Flat Washer to secure the Roof Bracket to the roof, **(Figure 10)**.
- d. Repeat the above Steps for the remaining (5) mounting locations on the roof.

### **Metris**

- a. Place and align (1) Rubber Spacer between the bottom of the Roof Bracket and the threaded inserts on the roof.
- b. Use (2) 6mm x 20mm Hex Bolts, (2) 6mm Lock Washers and (2) 6mm Flat Washers to secure the Roof Bracket to the roof, **(Figure 11)**.
- c. Repeat the above Steps for the remaining (5) mounting locations on the roof.

### **Transit**

- a. Place and align (1) 128mm x 51mm x 5mm Plate with (1) Rubber Pad in between the bottom of the Roof Bracket and the threaded insert on the roof.
- b. Use (1) 8mm x 30mm Hex Bolt, (1) 8mm Lock Washer and (1) 8mm x 16mm Flat Washer to attach the Roof Bracket to the roof, **(Figure 12)**.
- c. Repeat the above Steps for the remaining (5) mounting locations on the roof.

### **NV**

- a. Slide (2) 8mm Clip Nuts onto the mounting plates on the side of the roof with the nut towards the bottom. Line up the threaded nut on the clip with the hole on the mounting plate.
  - b. Use (2) 8mm x 20mm Hex Bolts, (2) 8mm Lock Washers and (2) 8mm x 16mm Flat Washers to attach the Roof Bracket to the roof, **(Figure 13)**.
  - c. Repeat the above Steps for the remaining (5) mounting locations on the roof.
7. Level and center the Cross Member assemblies to the vehicle and tighten all hardware at this time.
  8. Do periodic inspections to the installation to make sure that all hardware is secure and tight.

**To protect your investment**, wax this product after installing. Regular waxing is recommended to add a protective layer over the finish. Do not use any type of polish or wax that may contain abrasives that could damage the finish. Mild soap may be used to clean the Ladder Rack.

### **Read and understand all WARNINGS and INSTRUCTIONS before assembly and installation.**

Ladder Rack has a maximum static load capacity of 600lbs. when properly installed and the load distributed evenly between two complete units. Load capacity is greatly affected by the design, strength and capacity of the intended vehicle and must be determined by installer/user.

Ladders must be secured per ANSI standard A14.2-1990 paragraph 8.4.4.

This product is primarily intended for transporting ladders. It can be used for transporting lumber, pipe and other similar materials when properly tied down and not exceeding capacity of the ladder rack or more importantly, the vehicle. It is the responsibility of the user of this rack to safely secure these materials to the rack before transporting. Any modifications made to this product for any other purpose other than its intended use could create a hazardous condition that can cause serious personal injury or property damage.

Any modification or unintended use of this product shall immediately void all manufacturer's warranties. Manufacturer disclaims all liability for injuries to persons or property resulting from any modification to or unintended use of this product.

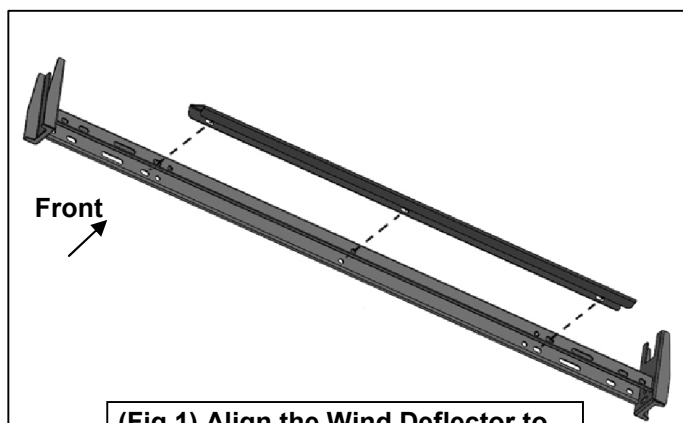

**(Fig 1) Align the Wind Deflector to the front face of the Cross member**

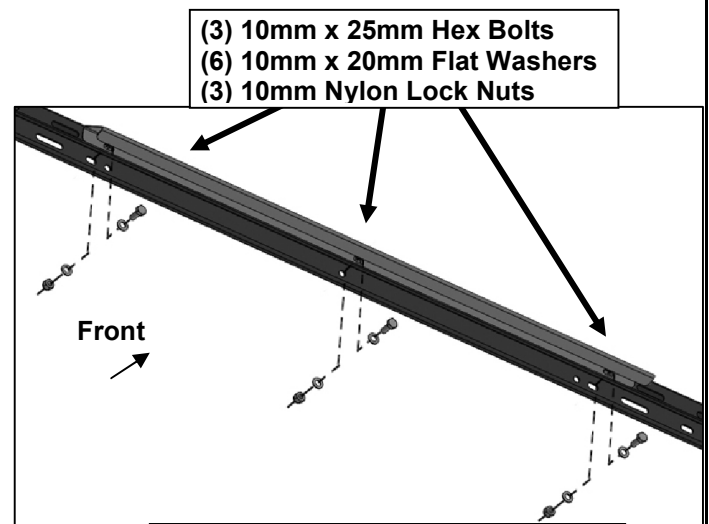

**(Fig 2) Wind Deflector attached to the front of the Cross Member**

- (3) 10mm x 25mm Hex Bolts
- (6) 10mm x 20mm Flat Washers
- (3) 10mm Nylon Lock Nuts

- (1) 10mm x 25mm Hex Bolt
- (2) 10mm x 20mm Flat Washers
- (1) 10mm Nylon Lock Nut

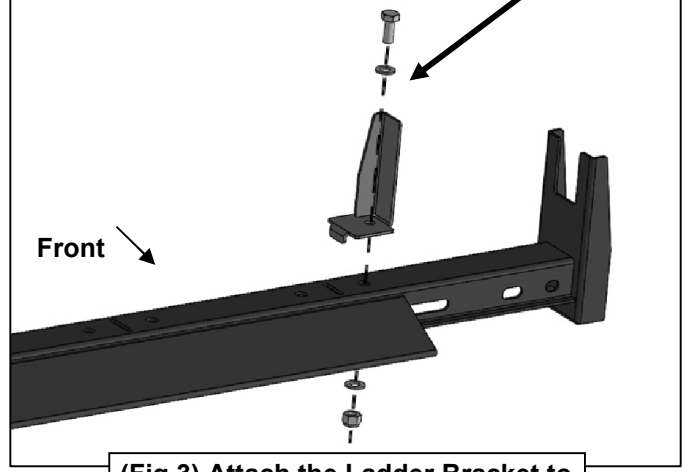

(Fig 3) Attach the Ladder Bracket to the top face of the Cross Member

Inner slot: NV200, City Express, Promaster City and Transit Connect

Outer slot: NV

Center slot: Transit & Metris

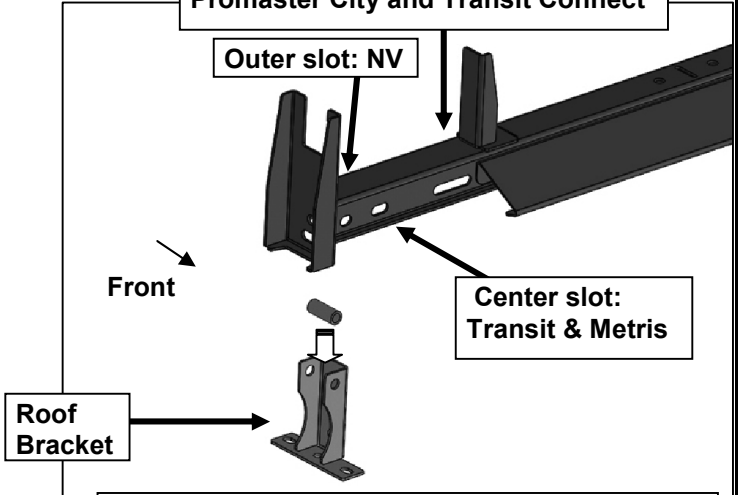

(Fig 4) Determine the correct mounting slot for the Roof Bracket on the Cross Member

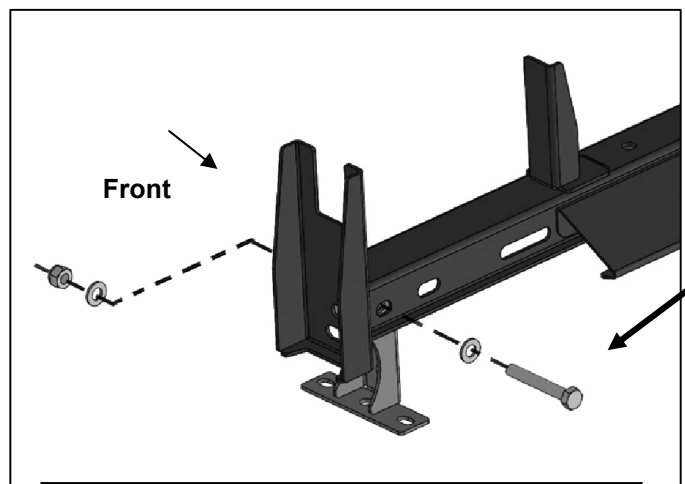

- (1) 10mm x 70mm Hex Bolt
- (2) 10mm x 20mm Flat Washers
- (1) 10mm Nylon Lock Nut

(Fig 5) Attach the Roof Bracket & Tube Spacer to the bottom of the Cross Member

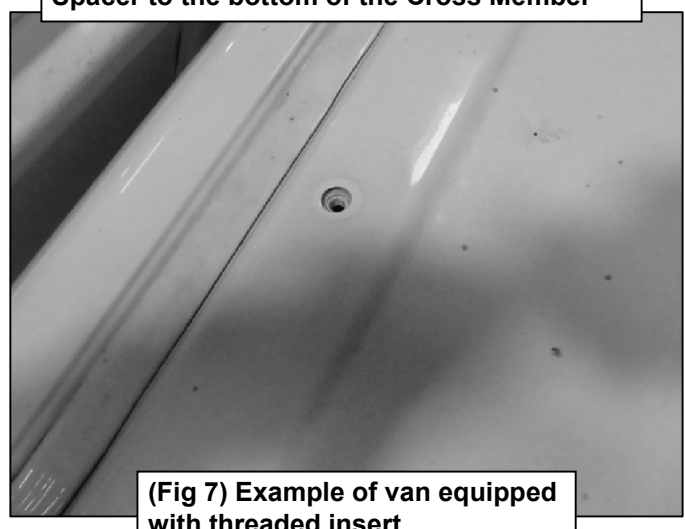

(Fig 7) Example of van equipped with threaded insert

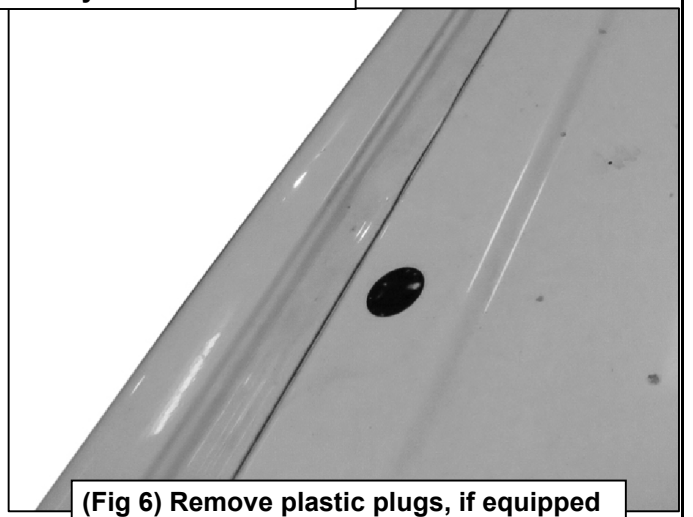

(Fig 6) Remove plastic plugs, if equipped

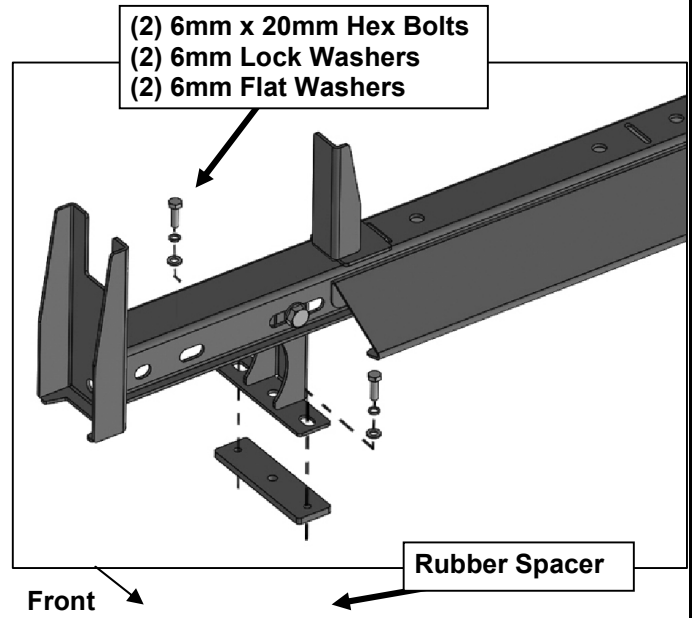

- (2) 6mm x 20mm Hex Bolts
- (2) 6mm Lock Washers
- (2) 6mm Flat Washers

Rubber Spacer

Front

(Fig 8) Installation of Roof Bracket to roof for Promaster City illustrated

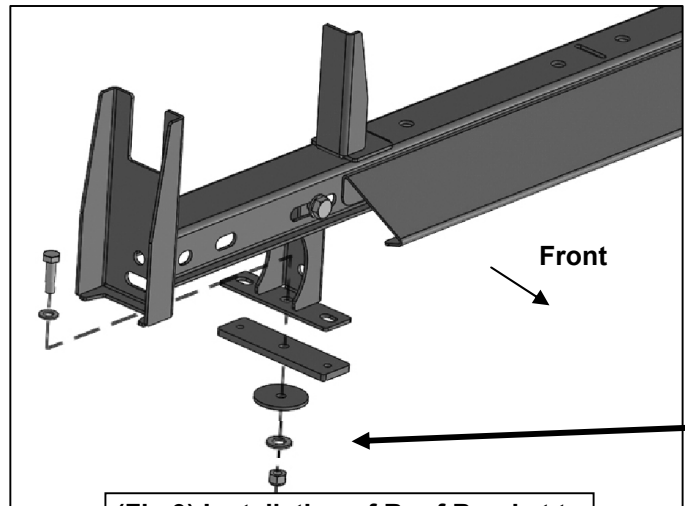

(Fig 9) Installation of Roof Bracket to roof for Transit Connect illustrated

- (1) 8mm x 30mm Hex Bolt
- (1) 8mm x 16mm Flat Washer
- (1) Rubber Spacer
- Roof
- (1) Rubber Washer
- (1) 8mm x 24mm Flat Washer
- (1) 8mm Nylon Lock Nut

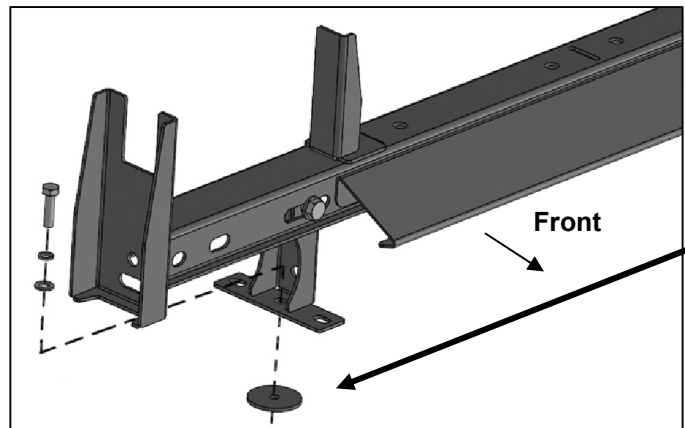

(Fig 10) Installation of Roof Bracket to roof for NV200 & City Express illustrated

- (1) 8mm x 30mm Hex Bolt
- (1) 8mm Lock Washer
- (1) 8mm x 16mm Flat Washer
- (1) Rubber Washer

- (2) 6mm x 20mm Hex Bolts
- (2) 6mm Lock Washers
- (2) 6mm Flat Washers
- (1) Rubber Spacer

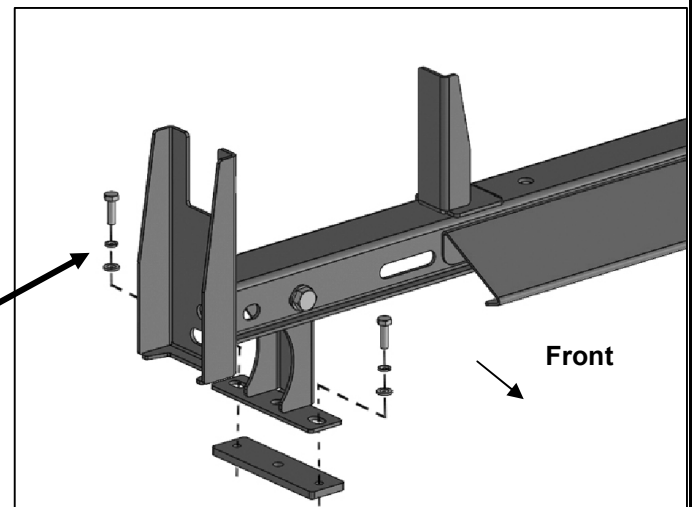

(Fig 11) Installation of Roof Bracket to roof for Metris illustrated

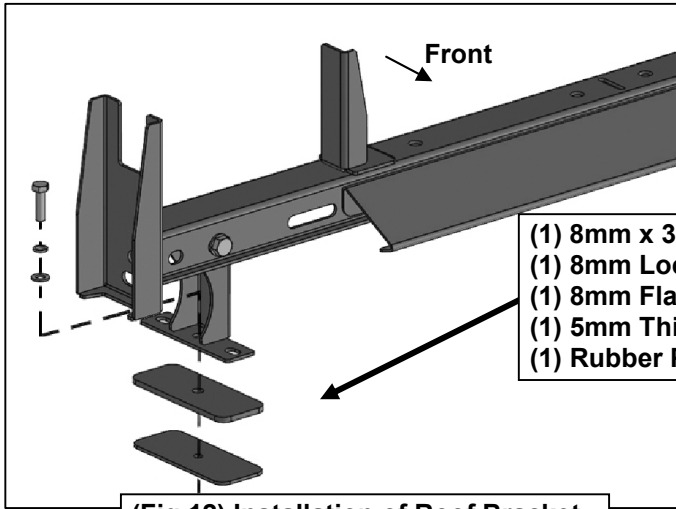

- (1) 8mm x 30mm Hex Bolt
- (1) 8mm Lock Washer
- (1) 8mm Flat Washer
- (1) 5mm Thick Plate
- (1) Rubber Pad

(Fig 12) Installation of Roof Bracket to roof for Transit illustrated

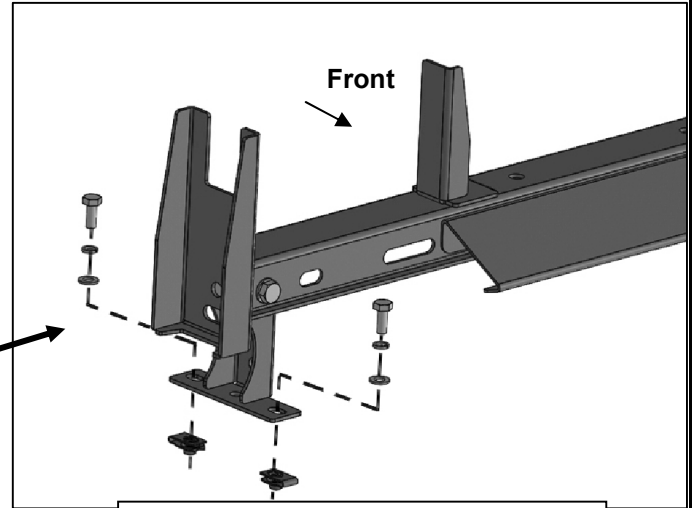

- (2) 8mm x 20mm Hex Bolts
- (2) 8mm Lock Washers
- (2) 8mm Flat Washers
- (2) 8mm U-Clips

(Fig 13) Installation of Roof Bracket to roof for NV illustrated

No.	Parts Identification
1	Passenger / Right 'Rear' Bracket marked "PR"
2	Driver / Left 'Rear' Bracket marked "DR"
3	Passenger / Right 'Center' Bracket marked "PC"
4	Driver / Left 'Center' Bracket marked "DC"
5	Passenger / Right 'Front' Bracket marked "PF"
6	Driver / Left 'Front' Bracket marked "DF"

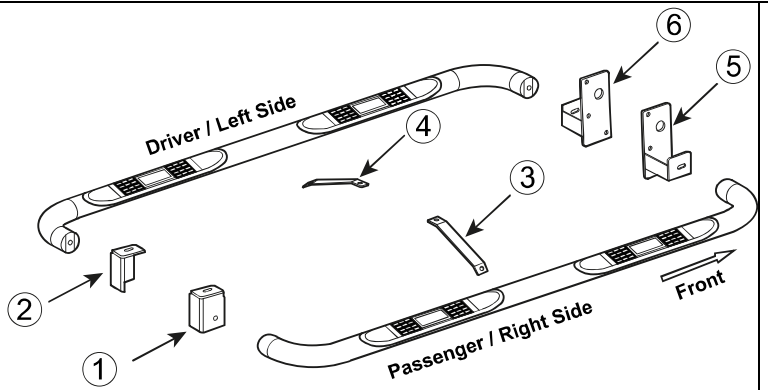

**Note:**

- This guide is to identify the parts and not a reference for part count.
- For part count, refer Parts List.
- Product / Bracket image is representative and actual design may vary.

**PRODUCT CARE**

- Periodically check the product to ensure all fasteners are tight and components are intact.
- Regular waxing is recommended to protect the finish of the product.
- **Use ONLY Non-Abrasive automotive wax.** Use of any soap, polish or wax that contains an abrasive is detrimental and can scratch the finish leading to corrosion.
- Aluminum polish may be used to polish small scratches and scuffs for **Stainless Steel finish.**
- Mild soap may be used to clean the product for both **Stainless Steel and Black finish.**

**FAQ's**

- 1. Hardware's are not of correct size.**  
*In GMC / Chevrolet truck model 2006 & up, customer needs to reuse the factory body bolts to install the bracket. If your vehicle is not GMC / Chevrolet 2006 & up, ensure that holes are not partially covered with any plastic grommet or rust? If it is, remove the plastic grommet & rust from the thread holes & re-try the installation.*
- 2. Mounting Bracket are not getting Installed properly.**  
*In some cases Illustration images shown in Installation manual may not be the exactly same as per actual vehicle images ,also if Driver / Passenger side mounting brackets are very identical in the design, suggest referring Parts Identification guide to avoid fitment issue.*
- 3. Products are thumping / rattling after installation.**  
*Ensure that all required mounting brackets / hardware's are installed & tighten correctly. Suggest using white lithium / regular grease between the metal to metal contact surfaces.*
- 4. Side Bar is not aligning with vehicle / Step Pads are not aligning with vehicle doors.**  
*Side bar may be interchanged or mounting brackets are not installed at the correct position in the vehicle. Refer Parts identification guide.*
- 5. Missing / Excess Hardware.**  
*Recheck hardware count as per the part list.*
- 6. Product not installing properly.**  
*Ensure make model year, cab length and bed size of your vehicle is listed in the application. All installation steps are followed correctly.*

**Check out these other TrailFX Products!!**



Keystone Automotive Operations Inc. (KAO) warrants this product to be free of defects in material and workmanship at the time of purchase by the original retail consumer. KAO disclaims any other warranties, express or implied, including the warranty of fitness for a particular purpose or an intended use. If the product is found to be defective, KAO may replace or repair the product at our option, when the product is returned prepaid, with proof of purchase. Alteration to, improper installation, or misuse of this product voids the warranty. KAO's liability is limited to repair or replacement of products found to be defective, and specifically excludes liability for any incidental or consequential loss or damage.