



LADDER RACK

Part No. FCLR006W



**Fits: Universal Crossbar Ladder Rack
Clamp-On For Models With Rain Gutter**



60-180 min

Cutting Not
Required

Drilling Not
Required



REMOVE CONTENTS FROM BOX. VERIFY ALL PARTS ARE PRESENT.



READ INSTRUCTIONS CAREFULLY BEFORE STARTING INSTALLATION.

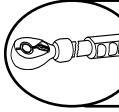

DO NOT OVER TORQUE. STANDARD OPERATING LOAD FOR TIGHTEN BODY MOUNT NUTS & BOLTS VARIES FROM 45 TO 65 FOOT POUND.

First of all, please check what model you have bought. Part lists for 1 bar model are different. Please find the related part list from below:

PARTS LIST for 1 Bars Model:

Qty	Part Description	Qty	Part Description
1	Main Cross Bar (female)	4	10-1.5mm x 35mm Carriage Bolts
1	Slide In Adjustable Cross Bar (male)	1	10-1.5mm x 20mm Hex Locking Bolts
2	Clamping Plates	4	10mm x 30mm OD x 2.5mm Flat Washers
1	U-Bolt Ladder Positioner	6	10mm Lock Washers
1	2-hole Clamp Plates	6	10mm Hex Nuts

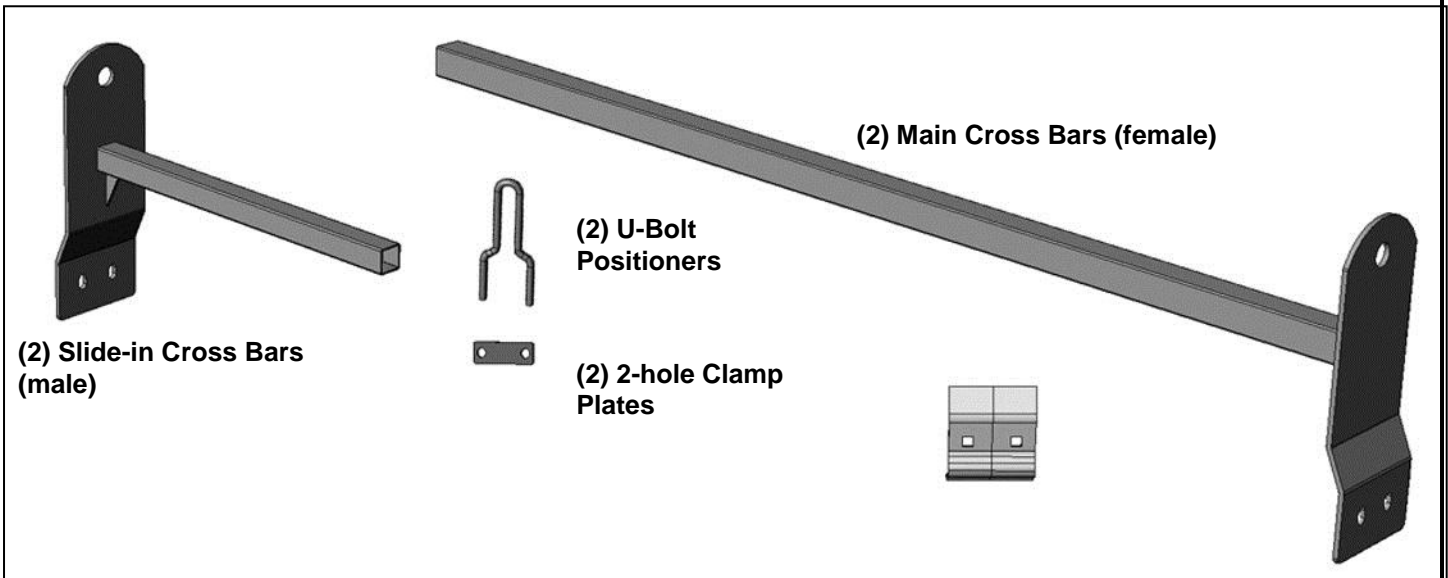

PROCEDURE:

1. REMOVE CONTENTS FROM BOX. VERIFY ALL PARTS ARE PRESENT. READ INSTRUCTIONS AND WARNING ON PAGE 2 CAREFULLY BEFORE STARTING INSTALLATION. ASSISTANCE IS RECOMMENDED.
2. Select (1) Inner Cross Bar and (1) Clamp Plate, **(Figure 1)**. Attach the Clamp Plate to the outside of the upright on the Cross Bar with the included (2) 10mm x 35mm Carriage Bolts, (2) 10mm Flat Washers, (2) 10mm Lock Washers and (2) 10mm Hex Nuts. Leave hardware loose at this time.
3. Repeat **Step 2** to assemble all (5) remaining Cross Bar inner and outer assemblies.
4. Select (1) inner and (1) outer Cross Bar assembly. Slide (1) Inner Cross Bar into (1) Outer Cross Bar, **(Figure 2)**. Lock in place with (1) 10mm Hex Bolt, **(Figure 3)**. Do not tighten locking bolt at this time.
5. Measure the width of the vehicle, rain gutter to rain gutter and transfer that measurement onto the complete Cross Bar assembly.
6. With assistance, place the Cross Bar assembly into the desired position at the front of the vehicle. **NOTE:** Install Cross Bars with the Outer Cross Bar toward the curb or right side of the vehicle. Snug but do not fully tighten all hardware at this time.
7. Repeat **Step 4—6** to install the remaining Cross Bar assemblies towards the center and rear of the vehicle.
8. Select (1) Load Positioner U-Bolt and (1) 2-Hole Clamp Plate, **(Figure 4)**. Slide the U-Bolt down and over the Outer Cross Bar. Secure the Positioner to the Cross Bar tube with the 2-Hole Lock Plate, (2) 10mm Flat Washers, (2) 10mm Lock Washers and (2) 10mm Hex Nuts. Adjust Load Positioner location and tighten hardware. Repeat this Step for the remaining (2) Cross Bar assemblies.
9. Verify that the Cross Bar assemblies are straight and square on the vehicle and fully tighten all hardware.
10. Do periodic inspections to the installation to make sure that all hardware is secure and tight.

To protect your investment, wax this product after installing. Regular waxing is recommended to add a protective layer over the finish. Do not use any type of polish or wax that may contain abrasives that could damage the finish. Mild soap may be used to clean the Ladder Rack.

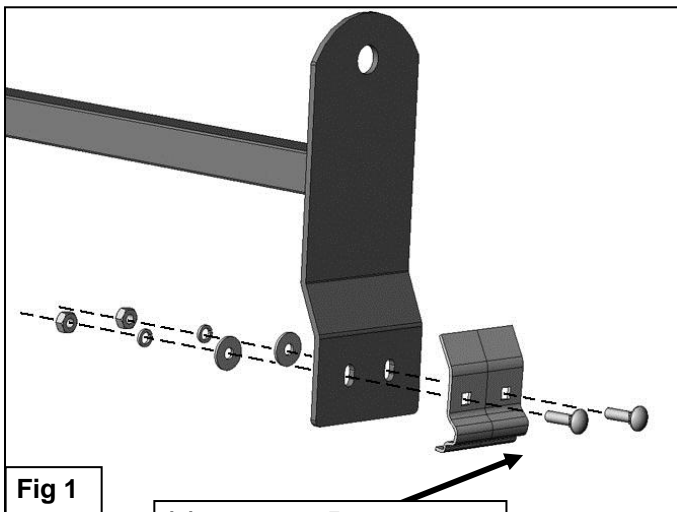
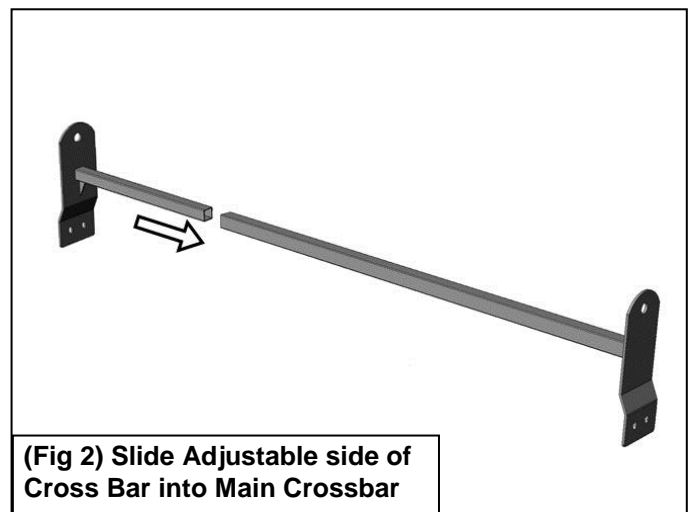
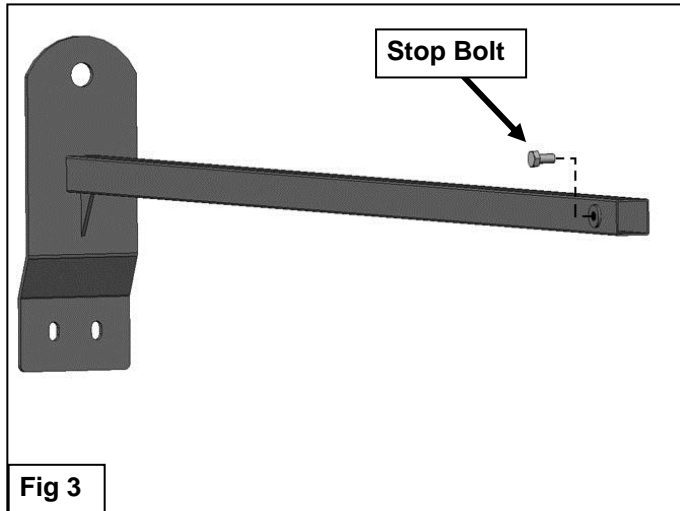

Fig 1

(2) 10mm x 35mm
Carriage Bolts
(2) 10mm Flat Washers
(2) 10mm Lock Washer
(2) 10mm Hex Nuts



(Fig 2) Slide Adjustable side of
Cross Bar into Main Crossbar



U-Bolt
2-Hole Clamp Plate
(2) 10mm Flat Washers
(2) 10mm Lock Washer
(2) 10mm Hex Nuts

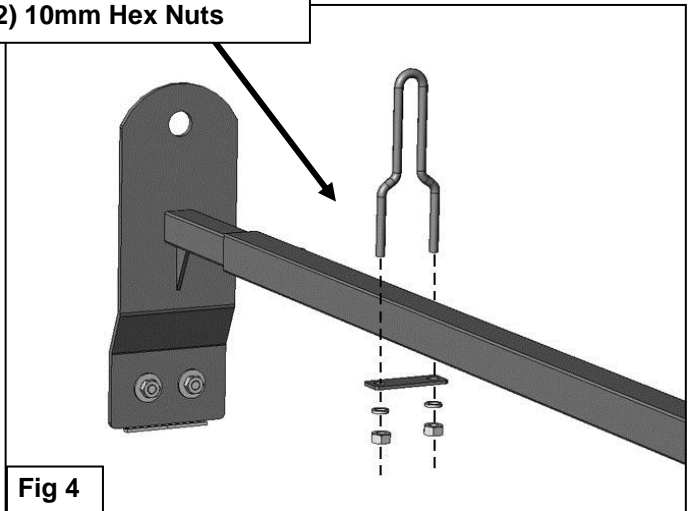

Read and understand all WARNINGS and INSTRUCTIONS before assembly and installation.

Ladder Rack has a maximum static load capacity of 600lbs. when properly installed and the load distributed evenly between two complete units. Load capacity is greatly affected by the design, strength and capacity of the vehicle, intended load and must be determined by installer/user.

Ladders must be secured per ANSI standard A14.2-1990 paragraph 8.4.4.

This product is primarily intended for transporting ladders. It can be used for transporting lumber, pipe and other similar materials when properly tied down and not exceeding capacity of the ladder rack or more importantly, the vehicle. It is the responsibility of the user of this rack to safely secure these materials to the rack before transporting. Any modifications made to this product for any other purpose other than its intended use could create a hazardous condition that can cause serious personal injury or property damage.

Any modification or unintended use of this product shall immediately void all manufacturer's warranties. Manufacturer disclaims all liability for injuries to persons or property resulting from any modification to or unintended use of this product.

No.	Parts Identification
1	Passenger / Right 'Rear' Bracket marked "PR"
2	Driver / Left 'Rear' Bracket marked "DR"
3	Passenger / Right 'Center' Bracket marked "PC"
4	Driver / Left 'Center' Bracket marked "DC"
5	Passenger / Right 'Front' Bracket marked "PF"
6	Driver / Left 'Front' Bracket marked "DF"

Note:

- > This guide is to identify the parts and not a reference for part count.
- > For part count, refer Parts List.
- > Product / Bracket image is representative and actual design may vary.

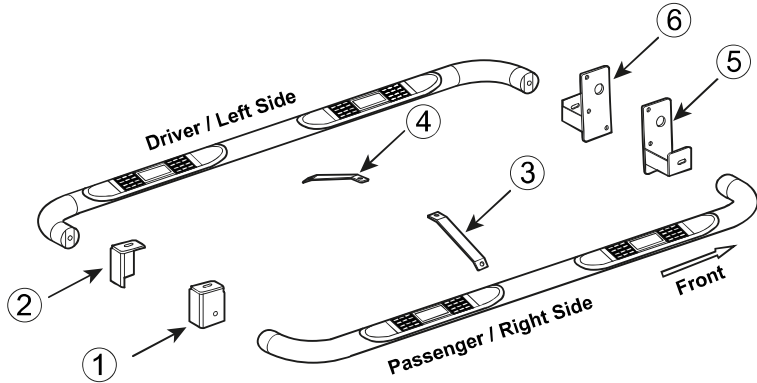

PRODUCT CARE

- Periodically check the product to ensure all fasteners are tight and components are intact.
- Regular waxing is recommended to protect the finish of the product.
- **Use ONLY Non-Abrasive automotive wax.** Use of any soap, polish or wax that contains an abrasive is detrimental and can scratch the finish leading to corrosion.
- Aluminum polish may be used to polish small scratches and scuffs for **Stainless Steel finish.**
- Mild soap may be used to clean the product for both **Stainless Steel and Black finish.**

FAQ's

1. **Hardware's are not of correct size.**
In GMC / Chevrolet truck model 2006 & up, customer needs to reuse the factory body bolts to install the bracket. If your vehicle is not GMC / Chevrolet 2006 & up, ensure that holes are not partially covered with any plastic grommet or rust? If it is, remove the plastic grommet & rust from the thread holes & re-try the installation.
2. **Mounting Bracket are not getting Installed properly.**
In some cases Illustration images shown in Installation manual may not be the exactly same as per actual vehicle images ,also if Driver / Passenger side mounting brackets are very identical in the design, suggest referring Parts Identification guide to avoid fitment issue.
3. **Products are thumping / rattling after installation.**
Ensure that all required mounting brackets / hardware's are installed & tighten correctly. Suggest using white lithium / regular grease between the metal to metal contact surfaces.
4. **Side Bar is not aligning with vehicle / Step Pads are not aligning with vehicle doors.**
Side bar may be interchanged or mounting brackets are not installed at the correct position in the vehicle. Refer Parts identification guide.
5. **Missing / Excess Hardware.**
Recheck hardware count as per the part list.
6. **Product not installing properly.**
Ensure make model year, cab length and bed size of your vehicle is listed in the application. All installation steps are followed correctly.

Check out these other TrailFX Products!!

