



# Contractor Ladder Rack

Part: FCLR001B



Fit: Universal



TO AVOID BEING SCRATCHED, PLEASE PROTECT THE SURFACE OF THE CONTRACTORS RACK CAREFULLY.



REMOVE CONTENTS FROM BOX. VERIFY ALL PARTS ARE PRESENT.



READ INSTRUCTIONS CAREFULLY BEFORE STARTING INSTALLATION.

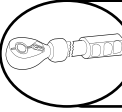

DO NOT OVER TORQUE. STANDARD OPERATING LOAD FOR TIGHTEN BODY MOUNT NUTS & BOLTS VARIES FROM **45** TO **65** FOOT POUND.



90 min

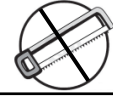

Cutting Not Required



Drilling Required



## IMPORTANT SAFETY INSTRUCTIONS



- Do not load any cargo on the Rack with the rear crossbar removed
- The Rack is rated for 1500 lb limit. Do not overload the Rack.
- Always balance the load.
- Read all instructions before attempting to assemble The Rack.
- After the Rack is fully assembled make sure all nuts and bolts are properly tightened.
- Periodically check for loose or missing bolts, nuts, etc.
- Follow instructions below to ensure proper assembly and installation. Failure to proper assemble and/or install the Contractors Rack may result in sever or fatal personal injury or property damaged. Keystone Automotive Operations, INC. is not responsible for injury or damage caused by improper installation or use.

### TOOLS NEEDED

Part Description	Part Description
Socket wrench set	Rubber mallet
Adjustable wrench	Drill and 5/16" bit (for permanent installation)
Tape measure	

### BEFORE YOU BEGIN

There are 16 pieces that makeup the Premium Contractors Rack (excluding hardware). On the next page there is a layout which shows the correct placement of these pieces for both, short bed and long bed truck. The placement is the same for short and long bed trucks.

**NOTE: If these components are not correctly positioned it will become necessary to disassemble the Rack and start over again.**

**INCLUDED COMPONENTS:**

	Qty	Part Description	Qty	Part Description
A	1	Cab Hoop	8	M10 x 70mm Hex Head Bolts
B	2	Front Side Rails	2	M10 x 35mm Hex Head Bolts
C	1	Driver Side Rear Side Rail	2	M10 x 25mm Hex Head Bolts
D	1	Passenger Side Rear Side Rail	12	M10 Lock Washers
E	1	Front Cross Bar	12	M10 Hex Nuts
F	1	Center Cross Bar	24	M10 Flat Washers
G	1	Rear Cross Bar	8	M12 x 60mm Hex Head Bolts
H	1	Driver Side Front Upright	16	M12 Lock Washers
I	1	Passenger Side Front Upright	16	M12 Hex Nuts
J	1	Driver Side Rear Upright	24	M12 Flat Washers
K	1	Passenger Side Rear Upright	8	M12 "J" Hooks
L	2	Mounting Feet (D/S Front – P/S Rear)	4	M18 x 90mm Hex Head Bolts
M	2	Mounting Feet (P/S Front – D/S Rear)	4	M18 Lock Washers
			4	M18 Hex Nuts
			8	M18 Flat Washers
			4	Lock Pins

**PERMANENT INSTALLATION HARDWARE**

Qty	Part Description	Qty	Part Description
12	M12 x 35mm Hex Head Bolts	12	M12 Hex Nuts
12	M12 Lock Washers	24	M12 Flat Washers

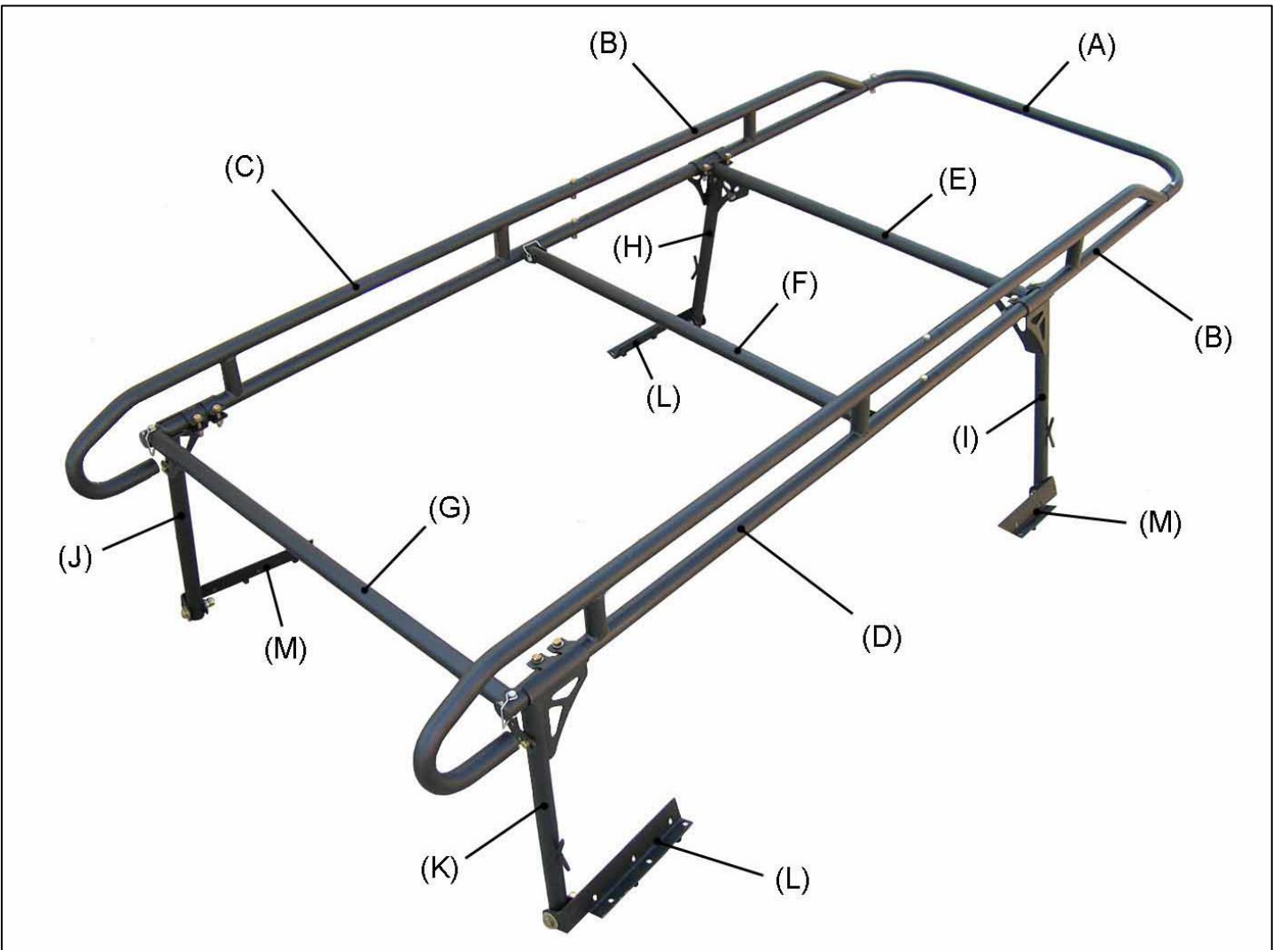

INCLUDED COMPONENTS  
ncluded components

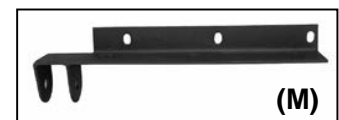
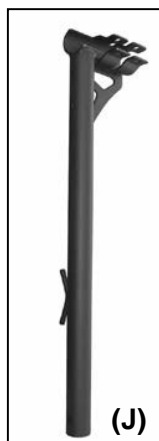
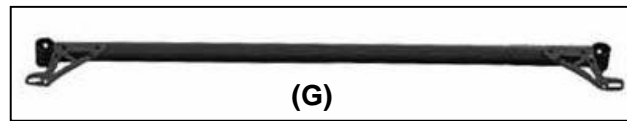
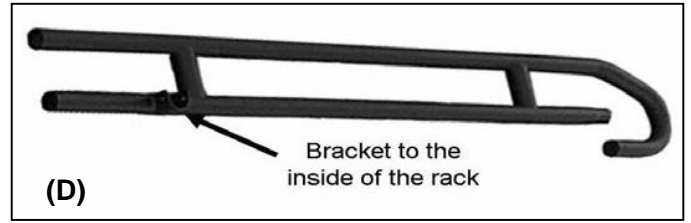
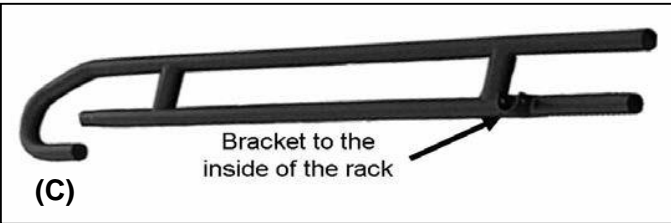
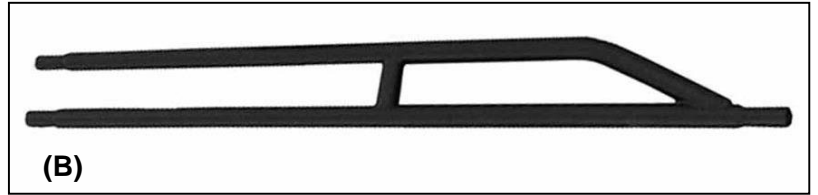
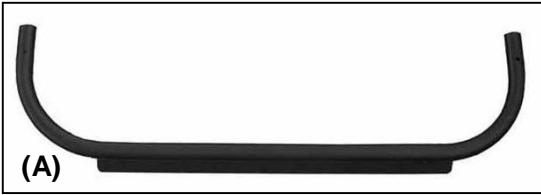

*Do not tighten any hardware until you have assembled all parts together.*

**Step 1:** Slide the driver side rear Upright into the back of the driver side Rear Side Rail. Loosely attach them together using the included (2) M12 x 60mm Hex Head Bolts, (2) M12 Lock Washers, (2) M12 Hex Nuts and (4) M12 Flat Washers (**Figure 1a**).

**NOTE:** The side where the bolts are located will mount to the inside of the Rack.

*Repeat this step for opposite side.*

**Step 2:** Install the rear Cross Bar over the end of the rear of both Side Rails and secure it using the included Lock Pins included. Attach the lower support bracket of the Rear Cross Bar to the Uprights using the included (2) M10 x 70mm Hex Head Bolts, (2) M10 Lock Washers, (2) M10 Hex Nuts, and (4) M10 Flat Washers (**Figure 2a**).

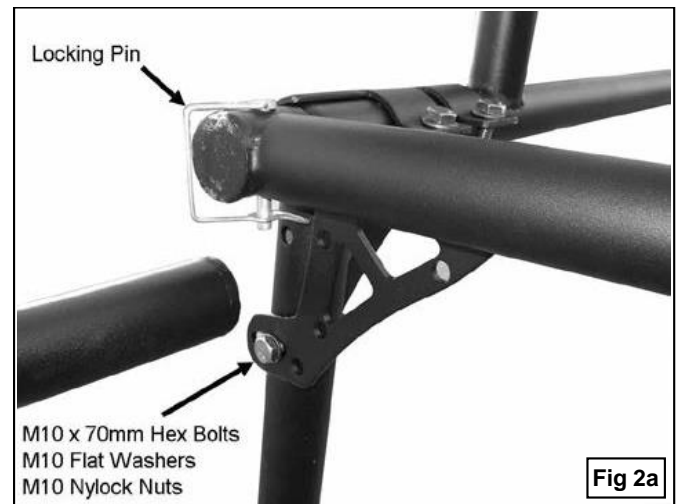
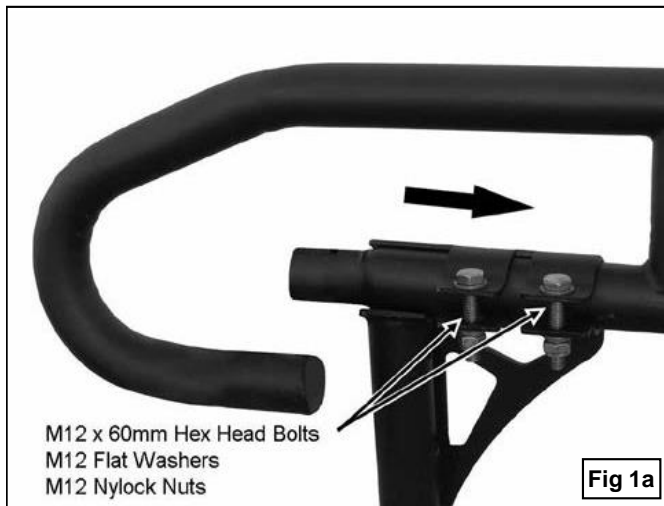

**Step 3:** Install the Center Cross Bar to both of the Rear Side Rails using the included Lock Pins (**Figure 3a**).

**Step 4:** Slide the driver side Upright into one of the front Side Rails and loosely attach it using the included (2) M12 x 60mm Hex Head Bolts, (2) M12 Lock Washers, (2) M12 Hex Nuts and (4) M12 Flat Washers (**Figure 4a**).

**NOTE:** You should be able to slide the Upright back and forth.

*Repeat this step for opposite side*

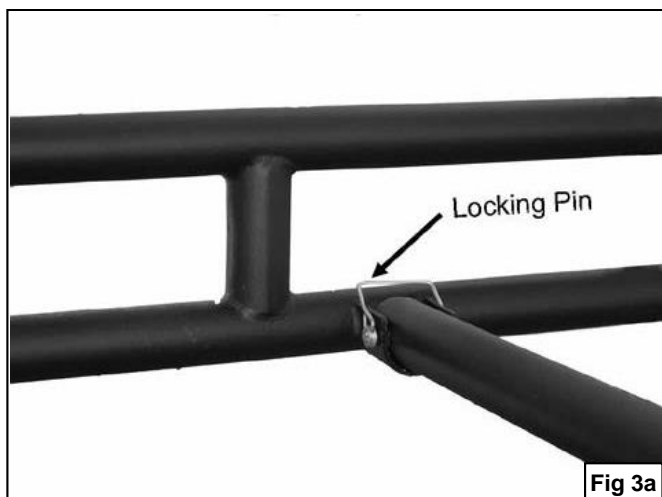

**Step 5:** Slide the front and rear Side Rails together (**Figure 5a**).

**Step 6:** Attach front and rear Side Rails using the included (4) M10 x 70mm Hex Head Bolts, (4) M10 Lock Washers, (4) M10 Hex Nuts and (8) M10 Flat Washers (Figure 6a).

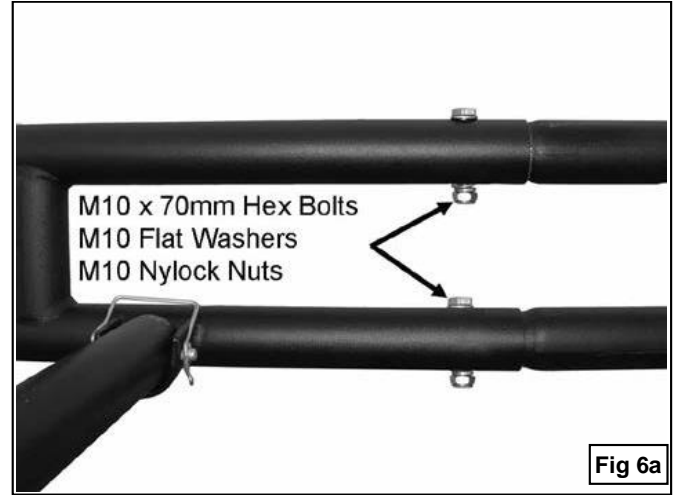
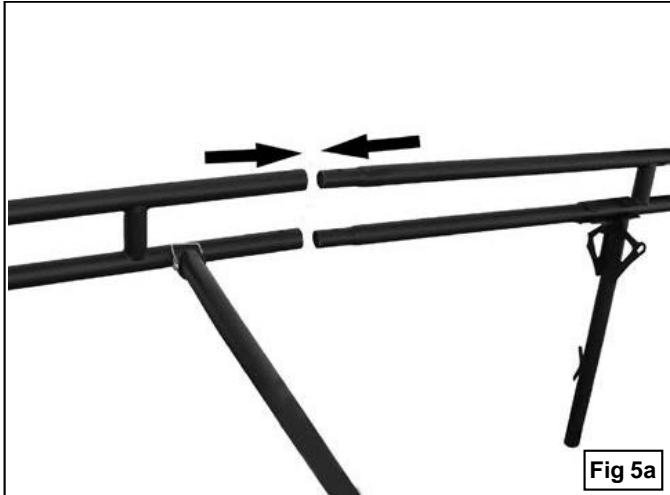

**Step 7:** Attach front Cross Bar to the tab located between the two clamps on each of the front uprights using the included (2) M10 x 35mm Hex Head Bolts, (2) M10 Lock Washers, (2) M10 Hex Nuts and (4) M10 Flat Washers. Attach the front Cross Bar's Support Brackets to the Support Bracket on each of the front Uprights using the included (2) M10 x 25mm Hex Head Bolts, (2) M10 Lock Washers, (2) M10 Hex Nuts and (4) M10 Flat Washers (**Figure 7a & 7b**).

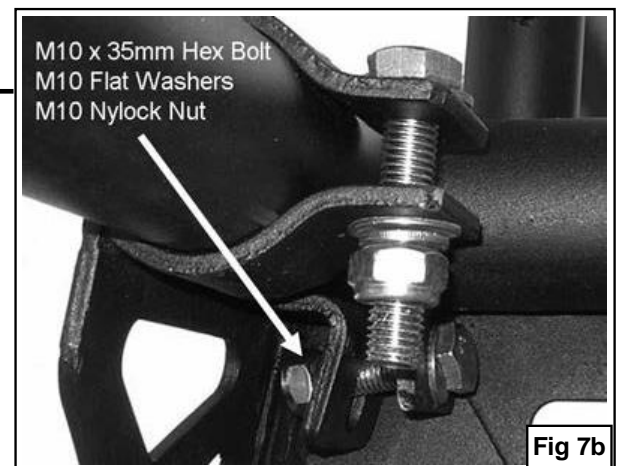

**Step 8:** Slide the Cab Hoop into the front Side Rails and secure it with the included (2) M10 x 70mm Hex Head Bolts, (2) M10 Lock Washers, (2) M10 Hex Nuts and (4) M10 Flat Washers (Figure 8a).

**Step 9:** Attach the feet to the Uprights using the included (4) M18mm x 90mm Hex Head Bolts, (4) M18 Lock Washers, (4) M18 Hex Nuts and (8) M18 Flat Washers (Figure 9a).

**NOTE:** The lip on the Mounting Foot must face towards the inside of the truck bed. The rear Uprights face the front of the truck and the front Uprights face the rear of the truck.

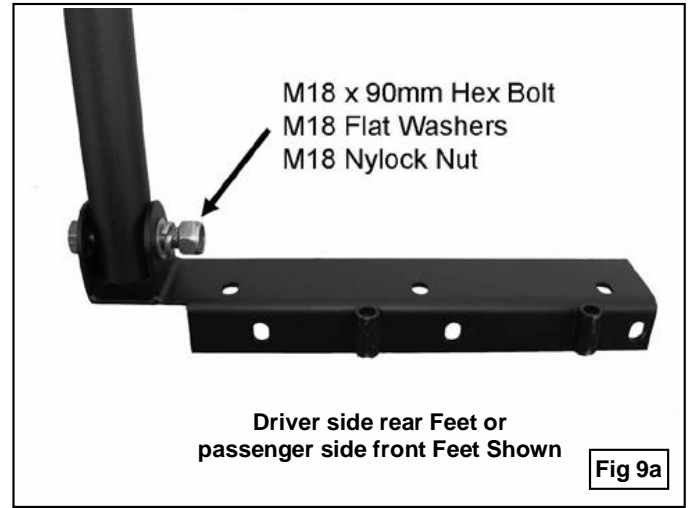
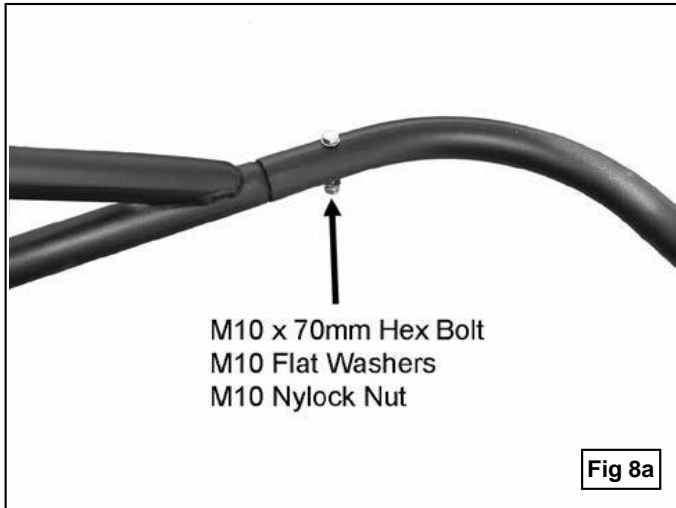

**NOTE:** Before lifting the Contractors Rack onto the truck bed, you will need to size it.

- Measure the length of the truck's bed with the tailgate closed.
- Subtract 4 inches from the measurement, which is the approximate spacing of the Uprights.
- Measure between the center of the Uprights and move the front Uprights backwards or forwards as needed.

**REMEMBER DO NOT TIGHTEN ANY BOLTS!**

**Step 10:** Your Contractors Rack should be fully assembled and sized for your truck at this time. The next step is the installation process and will require the help of 1 or 2 assistants to lift the Rack into position (**Figure 10a**).

- Lift the Rack onto the bed rails of the truck.
- Align the rear Mounting Feet as close as possible to the corner of the bed rail.
- Have your assistant position the front Mounting Feet as close as possible to the corner of the bed rails. NOTE: The Uprights can be adjusted while the Rack is on the bed.
- When you are satisfied with the spacing of the Uprights on the bed rails, proceed to attach the Rack to the truck in one or two ways: NO DRILL or DRILLING INSTALLATION.
- Please follow the instructions on the next page, which outline your choice of the installation method.



## No Drill installation

1. In order to safely attach the Contractors Rack to the truck bed, you must use (2) "J" Hooks per Mounting Foot to hold the Rack in place. In some truck beds there are obstructions under the bed rail which would prevent using (2) "J" Hooks. If you experience difficulty using (2) "J" Hooks per Mounting Foot because of under bed rail obstructions, you will need to re-adjust the Upright
2. Spacing in order to attach (2) "J" Hooks.
3. Insert "J" Hooks from the bottom of the Mounting Foot and engage them under the bed rail.
4. Secure the "J" Hooks to bed rail using (2) 12mm Flat Washers and (2) 12mm Nylock Nuts.
5. If any portion of the threaded part of the "J" Hook remains above the bed rail, cut it off using a hacksaw or bolt cutter.

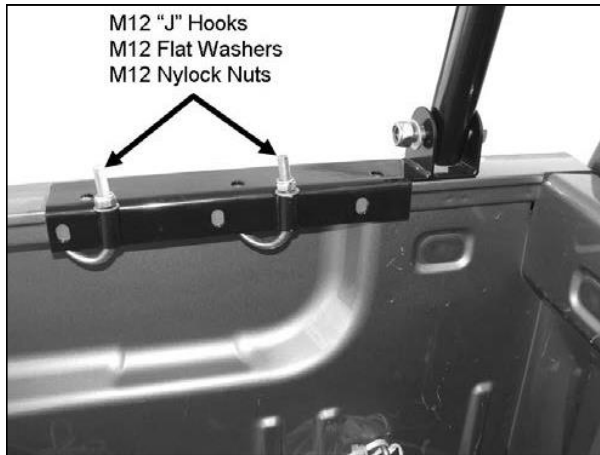

## Drilling Installation

1. Stand on the outside of the truck bed. Pull the Mounting Foot towards you until the lip of the Mounting Foot sits firmly against the edge of the bed.
2. Mark the three slots on the top of the Mounting Foot using a felt tip marker.
3. Repeat steps 1 & 2 for the other three Mounting Feet.

**NOTE:** Ensure that the rear feet and front feet are in the same locations, in relation to the front and rear of the bed.

**IMPORTANT!** Before drilling your vehicle's bed rail, check to see if you have a clear hole from the top of the bed rail to the underside. You will need a minimum of (2) bolts to attach each Mounting Foot to the vehicle. If you do not have (2) clear holes, re-adjust the spacing of the Uprights on the bed rails until you do.

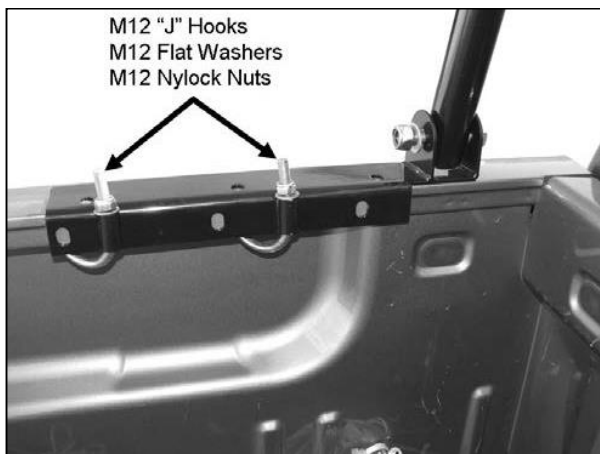

4. Using a 5/16" drill bit, drill all marked locations on the vehicle's bed rails.
5. Apply a small amount of rust inhibitor (not included) to the metal surface before attaching the Mounting Feet to the bed rail.
6. Secure the Mounting Feet to the vehicle using (12) 12mm x 40mm Hex Head Bolts, (24) 12mm Flat Washers, and (12) 12mm Nylock Nut.